

Central Area Guideway Coyote Creek Geotechnical Investigation Report

(P0503-D300-RPT-DE070, Rev.0)



Central Area Guideway

**Coyote Creek
Geotechnical
Investigation Report**

January 21, 2010

Issued for Use



Central Area Guideway

Coyote Creek

Geotechnical

Investigation Report

January 21, 2010
Issued for Use



This page is intentionally left blank.

COYOTE CREEK GEOTECHNICAL INVESTIGATION REPORT

FOR

ENGINEERING READINESS WORK PHASE

Contract No. S03099

Submitted by: HMM/Bechtel SVRT, a Joint Venture

for  11/21/10
J. Ike Isaacson, C.E.G.²⁵²⁷, P.G.⁷⁹¹⁹, P.E. Date
Tunnel Engineer

Reviewed by:

 1/21/10
Andrew Liu, G.E. Date
Central Area Guideway Geotechnical Lead

Approved by:

 1/22/2010
Michael Lehnen, P.E. Date
Central Area Guideway Design Manager



**Prepared by
HMM/Bechtel SVRT,
a Joint Venture**



This page is intentionally left blank.

TABLE OF CONTENTS

1.0 Executive Summary.....	1
2.0 Introduction.....	1
2.1 Background.....	1
2.2 Location and Purpose.....	1
2.3 Scope and Objectives.....	2
2.4 Planned Methods.....	2
2.5 HMM/Bechtel Sub-Contractors.....	3
2.6 Permits and Letters Governing the Work.....	4
3.0 Implementation and Results.....	5
3.1 Bridge Scanning and Coring.....	5
3.2 Work Site Isolation and Preparation.....	6
3.3 Soil Investigation.....	7
3.3.1 Sonic Drilling.....	8
3.3.2 Samples and Core Storage.....	8
3.3.3 Abandonment.....	8
3.4 Site Cleanup and Restoration.....	9
3.5 Bridge Patching and Demobilization.....	10
3.6 Survey.....	11
4.0 Analysis and Interpretation.....	11
4.1 Laboratory Testing.....	11
4.1.1 Cohesive Soils.....	11
4.1.2 Non-Cohesive Soils.....	12
4.1.3 Coyote Creek Bridge Concrete.....	12
4.2 Temporary Artesian Condition.....	13
4.3 Hydraulic Connection to Coyote Creek.....	13
4.4 Coyote Creek Bridge Structure.....	13
5.0 Conclusions and Recommendations.....	14

LIST OF FIGURES

- Figure 1 – Site Location Map (D300-S-TR-C168)**
- Figure 2 – Photo of Planned BH-107 Location on Coyote Creek Bridge**
- Figure 3 – Photo of Planned BH-107 Location Below Coyote Creek Bridge**
- Figure 4 – Bridge Plan and Section (D300-S-TR-C171)**
- Figure 5A - Geotechnical Plan and Profile Legend (D300-S-TG-C001)**
- Figure 5B - Geotechnical Plan and Profile (D300-S-TR-C169)**
- Figure 6 – Traffic Control Plan**
- Figure 7 – Bridge Patch As-Built Drawing (D300-S-TR-C172)**
- Figure 8 – Photo of Marked Deck Reinforcement Locations**
- Figure 9 – Photo of Bridge Inspection Truck**
- Figure 10 – Photo of Completed Core Hole Through Bridge Deck**
- Figure 11 – Photo of Sand Bag Crane Operation**
- Figure 12 – Photo of Conductor Casing and Isolation Tub at Ground Surface**
- Figure 13 – Photo of Drilling Operation on Bridge Deck**
- Figure 14 – Photo of Restored Work Area Beneath Bridge**
- Figure 15 – Photo of Patch Reinforcement**
- Figure 16 – Photo of Installed Patch**
- Figure 17 – Photo of Completed and Restored Bridge After Work Completion**

LIST OF APPENDICES

- Appendix A – BH-107 Boring Log**
- Appendix B – BH-107 Soil Laboratory Test Results**
- Appendix C – Structural Calculations for Equipment and Bridge Patch
(SGENS01-Rev. A)**

1.0 Executive Summary

The geotechnical investigation at the Santa Clara Street Bridge over Coyote Creek in San Jose, California was conducted from August 17th through August 21st, 2009. The purpose of the boring was to sample and confirm the soil profile of the SVRT tunnel alignment at the Coyote Creek channel, shown in Figures 5A and 5B. It was also implemented to investigate if the creek was hydraulically connected to the sands and gravels below, for the purposes of designing the Earth Pressure Balance (EPB) Tunnel Boring Machines (TBM) to be used to construct the tunnels for the project.

The work successfully installed a core hole through the bridge deck without encountering reinforcement. The sonic drilling and sampling of BH-107 to a depth of 123 ft below the bridge deck (90 ft below the creek bottom) was conducted from the bridge deck and indicated continuity of the cohesive soils at the tunnel horizon presented in the 65% Design. A temporary, potentially artesian condition and odorless out-gassing was experienced upon penetration through the confining layer of the upper confined aquifer. Based on water levels and potential artesian conditions noted, there does not appear to be a hydraulic connection between the borehole sands and gravels and the overlying Coyote Creek. The boring was abandoned and grouted closed, and a reinforced concrete patch was installed in the core hole through the bridge deck. The successful completion of the work was accomplished largely through the effective coordination of multiple on-site contractors that were required to perform the work. Each on-site contractor executed their respective tasks while working closely together with other on-site contractors to accomplish the work successfully.

Previously, HMM/Bechtel has prepared Geotechnical Data Reports (GDRs) upon completion of exploratory field investigations. However, during the current Engineering Readiness Work (ERW) phase of the project neither a GDR or an updated Geotechnical Baseline Report (GBR) will be prepared. Therefore, this report combines both factual information from the drilling program (typically included in the GDR), along with interpretive information used for design and setting contractual geotechnical baselines for construction (typically contained in the GBR). During the next phase of design, the information in this report will be incorporated in the updated versions of the GDR and GBR, thus superceding this report.

2.0 Introduction

2.1 Background

The 65% Engineering Phase geotechnical investigation for the Central Area Guideway (CAG) of the Silicon Valley Rapid Transit Project through San Jose did not include the drilling of a boring in Coyote Creek at the Santa Clara Street Bridge. This boring could not be conducted during the 65% phase due to the permit application process.

Permit applications for the work to drill BH-107 received final approval at the end of July 2009, and the work was scheduled for the following month.

2.2 Location and Purpose

BH-107 was located on the Santa Clara Street Bridge over Coyote Creek in San Jose, California (Figures 1 and 2). A location was selected between Pier Nos. 2 and 3 on the

north side of the bridge, as shown in Figures 3 and 4, which would allow the boring to be conducted from the bridge deck and in close proximity to the active channel of Coyote Creek, without actually requiring drilling operations within the channel itself. The bridge deck was chosen as the primary work site due to environmental restrictions which prohibited equipment below the bridge.

The purpose of the boring was to sample and confirm the soil profile of Coyote Creek channel for the SVRT tunnel alignment proposed north of the bridge, shown in Figures 5A and 5B. It was also implemented to investigate potential hydraulically connections between the creek bottom and sands and gravels below the tunnel invert.

2.3 Scope and Objectives

The scope of work for this project included the following major tasks:

- Provide measures to protect the environment of Coyote Creek from the work
- Provide traffic control measures to protect the work area from Santa Clara Street traffic
- Scan the bridge deck to pinpoint the location of internal reinforcement
- Core a hole through the concrete bridge deck to allow drilling to be conducted by equipment parked in the north lane of the bridge
- Perform sonic drilling to sample soils beneath Coyote Creek down to approximately El. -30 ft while environmentally protecting the creek
- Transport the retrieved soil cores to the SVRT core storage facility
- Perform a grout abandonment of BH-107 once drilling and sampling were completed while environmentally protecting the creek
- Patch the core hole through the bridge deck
- Perform laboratory soil testing on bore hole samples
- Survey the as-built position and elevation of the completed boring

2.4 Planned Methods

Traffic diversion around the work area on the bridge was planned to protect the workers. A traffic control plan was submitted under the City of San Jose encroachment permit to the city, and is shown in Figure 6. Crash barrels, lane delineators, signage, and perimeter fencing were all incorporated into the plan.

Ground penetrating radar (GPR) was utilized to select the position of a core hole through the bridge deck that would not damage or cut the existing bridge reinforcement within the deck. Due to the estimated 5 inch thickness of the asphaltic concrete (AC) overlay above the 8 3/4" inch thick concrete bridge deck, scanning from both the top and bottom surfaces of the bridge deck was anticipated in order to accurately locate the reinforcement prior to coring. It was later discovered that only scanning from the top of the bridge deck would be necessary.

To scan the base of the bridge deck, personnel access was required approximately 30 feet above the ground surface at the creek. A truck-mounted, multi-articulated boom was utilized to provide access to the base of the bridge deck and was parked on the bridge deck, where personnel and equipment could be loaded into the basket.

Conventional concrete coring equipment was used to core the hole through the bridge deck. Isolation of the work area below the bridge was a requirement in several permits, and sandbags were selected to provide the isolation barrier required. In order to safely transport the sandbags, a crane truck was used to lower and hoist pallets of sandbags to the work area beneath the bridge from the bridge deck. Protective measures such as tarpaulins and plywood sheeting were used to protect the culturally sensitive tile artwork on the bridge guardrail during crane and drilling operations.

Sonic drilling was selected for BH-107 to mitigate the potential environmental hazard posed by drilling with mud-rotary methods from the bridge deck: high hydraulic loads on casing seals presenting a higher probability of leakage to the creek and nearby storm drains. Initially, drilling to recover a 6-inch diameter core was planned, but required an 8.5 inch OD conductor casing through the core hole in the bridge deck. In order to gain additional clearance, a decision was made to reduce the recovered core to a 4-inch diameter, which reduced the required conductor casing diameter to 7 ¼ inches OD. This added an additional ¾-inch clearance to the anticipated longitudinal rebar within the bridge, reducing the chances of damaging or cutting a rebar during the coring work.

Patching of the core hole through the bridge deck utilized a high-strength epoxy mortar capable of taking traffic loads within just a few hours. Reinforcement detailing was added to provide shear resistance within the patch, as shown in Drawing D300-S-TR-C172 (Figure 7).

2.5 HMM/Bechtel Sub-Contractors

The successful completion of the work was accomplished largely through the effective coordination of multiple on-site contractors that were required to perform the work. Each on-site contractor executed their respective tasks while working closely together with other on-site contractors to accomplish the work successfully.

Digital Concrete Scanning Services (DCSS) performed GPR scanning of the bridge deck.

Boart Longyear performed sonic drilling, hole abandonment, and provision of equipment for environmental sandbagging and bridge inspection.

Towill performed the as-built position and elevation survey after the work at BH-107 had been completed.

Parikh Consultants, Inc. provided traffic control, laboratory testing, and program coordination support. Parikh coordinated their sub-consultants to provide bridge coring and patch installation work, traffic control equipment and personnel, drill waste testing and disposal, and work area perimeter fencing.

Penhall Company was a sub-consultant to Parikh for conducting bridge coring and patching operations.

Highway Technologies was a sub-consultant to Parikh for providing traffic control equipment and personnel during the work on Santa Clara Street.

Integrated Waste Management was a sub-contractor to Parikh and provided IDW barrel containers, testing, and disposal services for the drilling effort.

Norcal Portable Services was a sub-contractor to Parikh and provided the perimeter fencing around the work site on the bridge deck.

2.6 Permits and Letters Governing the Work

Multiple permits governed and regulated the work at Coyote Creek. These permits were granted by Federal, State, and local government agencies. The permits and letters which dictated the working conditions are listed below:

- City of San Jose – Encroachment Permit No. 3-07004RU
- Santa Clara Valley Water District – Exploratory Boring Permit No. 09E00068
- Santa Clara Valley Water District – Letter No. 26326
- California Regional Water Quality Control Board, San Francisco Bay Region, Site No. 02-43-C0614, CIWQS Place No. 740981
- California Department of Fish and Game – Notification of Lake or Streambed Alteration Notification No. 1600-2008-0458-3
- National Marine Fisheries Service Letter No. 2009/06454
- United States Army Corps of Engineers, Nationwide Permits 6 No. 08-00374S

In addition to the permit requirements, the City of San Jose also required stamped calculations by a licensed structural engineer for checking equipment loading and the planned patchwork prior to commencement of work at the site. The submitted structural calculations, No. SGENS01 Revision A, are included in Appendix C.

3.0 Implementation and Results

The fieldwork for the geotechnical investigation began on Monday, August 17 and was completed on Friday, August 21, 2009. The work area on the bridge was pre-marked by USA (USA Notice No. 0243976) the week before work was scheduled to begin. Except for PG&E lines, all utilities locations had been marked the previous week. A final position survey was conducted within a week of work completion. The field work is described in the sections below.

3.1 Bridge Scanning and Coring

On Monday, August 17th at 8:30am, work began by implementing a temporary lane closure for the northern lane of the bridge. The lane closure was implemented by Parikh, their sub-consultant Highway Technologies, and two uniformed San Jose Police Officers. The approximate location of BH-107 was marked with chalk, as was the centerline and outboard limit of Girder No. 2 beneath the southern edge of the north sidewalk. The girder position was marked as an aid to position equipment outriggers later in the day.

A Pacific Gas and Electric (PG&E) crew came on-site to mark their lines as work locating the reinforcement within the bridge deck was beginning.

Following this, Digital Concrete Scanning Services (DCSS) commenced a deep Ground Penetrating Radar (GPR) scan to locate rebar reinforcement within the bridge deck. This scan was conducted from the top of the deck through the asphaltic concrete (AC). Temporary marks were made where the large, deep scan transceiver indicated rebar within the deck. During this scan, a conduit was located at the northern edge of the scan area just below the AC surface. The city confirmed that though the USA marking was red in color, this in fact was their fiber optic traffic control communications line.

A high-resolution GPR scan was then conducted across the AC surface using a smaller transceiver. The scan clearly identified the locations of the rebar in both the longitudinal and transverse directions within the deck, as well as the fiber optic conduit. The final positions were then marked with paint on the AC surface, as shown in Figure 8. Longitudinal rebar reinforcement was typically spaced at 11 inches. Transverse rebar were typically spaced at 16 inches. One position was indicated where longitudinal rebar were spaced at 13 inches, and the core hole was positioned at this location to provide the maximum possible clearance between the rebar and the core hole wall. The indicated core hole location was painted onto the AC surface and measured relative to both the north curb nose and Pier No. 3 centerline. Measured distances are indicated in Figure 7.

Upon completion of the scanning and marking of the core hole location on the upper surface of the bridge deck, Boart Longyear positioned a Bronto bridge inspection truck in the north lane of the bridge in preparation for scanning the underside of the deck. Outriggers were positioned to rest over the centerline of girder no. 2 based on the previously placed chalk marks. A worker was placed within the inspection basket, which was then maneuvered over the north rail of the bridge, as shown in Figure 9. The arm lengths of the inspection truck, coupled with the dimensions of the guardrail and depth of girder no. 2, limited the proximity with which the inspection basket could be placed to the intended core hole location beneath the bridge. After several failed attempts at

positioning the inspection basket close enough to safely reach the bottom surface of the bridge deck, the worker was brought back to the top of the bridge. Boart Longyear proposed to have anchors installed on Girder Nos. 1 and 2 to provide for a safe working environment. After discussing multiple options, Digital Concrete Scanning Services indicated their confidence with the indicated positions of the rebar with only the top-side scan of the deck and felt that scanning the base of the deck was no longer necessary. Based on this recommendation from DCSS, the decision was made to proceed with coring without the base scan of the deck. The Bronto bridge inspection truck was then de-rigged and demobilized from the site.

Due to the inclined surface of the AC and road surface crown, the marked core hole location (indicated in white in Figure 8) was relocated $\frac{3}{4}$ inch towards the crown of the bridge to facilitate a vertical hole through the inclined rebar grid, which was in the bottom 2 inches of the bridge deck. The thickness of the deck was estimated at 13 inches based on the GPR scan, which was then assumed in the offset calculation.

In order to catch the core, drilling debris, and any dripping fluids that may fall from the core hole upon break through, Boart Longyear suspended a set of tarpaulins beneath the bridge from the base of the guardrail posts on the north and south side of the bridge.

Next, Penhall personnel set up to core through the bridge deck at the marked and cleared location indicated by the GPR scanning. The coring machine was aligned vertically and an 18" OD core bit was installed. The 18" core bit was drilled, with cooling water, into the AC surface of the deck approximately 4.5 inches, at which time coring was stopped. The AC core was free within the hole and was removed. A chipping gun was used to remove the remaining remnants of the AC down to the original concrete surface of the bridge deck.

The 8" OD core bit was then installed and coring recommenced. The bit was advanced to a depth of 7 inches into the $8\frac{3}{4}$ " thick concrete deck. Coring was then suspended and the 7 inch core was broken off at the base and removed from the hole. This left the last couple of inches to be cored through the deck, which would fall out of the base of the bridge. Coring recommenced and at a depth of 8 inches cooling water was no longer used to protect the creek below. The 8" core successfully broke through without striking any rebar within the bridge deck. Figure 10 shows a photograph of the completed core hole through the bridge deck. The core and debris were caught by the tarpaulin below the bridge, lowered to the ground, and removed.

3.2 Work Site Isolation and Preparation

For temporary cover, a steel plate with a section of 7" OD steel casing welded perpendicular to its base was installed in the core hole. Asphaltic material was added around the edge of the plate to provide a ramp around the exterior for traffic. After the temporary cover and ramp material were installed, the north lane was reopened at the end of the day on Monday.

On Tuesday, August 18th, work commenced with the establishment of a temporary double lane closure and mobilization of a Terex crane truck onto the bridge. After the outriggers were positioned, the crane truck transported four pallets of sandbags from a support truck, over the north guardrail of the bridge, and onto the ground below as shown in Figure 11. A 6-foot diameter plastic tub was then lowered to the ground below the bridge. At this point the support and crane trucks were demobilized, and a more permanent lane closure was implemented. Perimeter fencing was installed around the drill rig and support truck in the north lane of the bridge and crash barrels and lane delineators were installed on the traffic side of the fence barrier. Once the fencing, barrels, and delineators were in place, the north lane closure remained in place until the hole was abandoned.

The temporary core hole cover plate was then removed and a plumb-bob was lowered through the core hole to the ground surface below the bridge. Based on the indicated position below the bridge, the ponded area was raked to clear debris from the boring location by Boart Longyear personnel in personal protective equipment including Tyvek suits, gloves, and muck boots. This work was conducted under the supervision of an independent biologist. After debris within the water was cleared to the sides, the circular tub was floated into position with the hole in the base of the tub directly over the borehole location. The tub was then weighted down into the soil base of the ponded area by installing sandbags within the tub perimeter as well as around the exterior base of the tub to establish a seal.

The Boart Longyear PS sonic drill rig and support truck were then mobilized onto the bridge over the core hole and set up. The first 5 feet of soil was hand augered to confirm utility clearance prior to drilling. The native soil spoil produced by the hand augering was stockpiled for later use. Fifty gallon drums used to store and dispose of investigative derived wastes (IDW) were delivered to the site. Due to missing equipment adapters, casing installation and drilling were postponed until Wednesday. The drill rig and support vehicle remained on the bridge within the lane closure overnight.

On Wednesday, August 19th, the 7 ¼” OD conductor casing was installed through the core hole in the bridge deck, through the hole in the lower tub containment area, and seated into the ground below the bridge approximately 5 feet to establish a good seal with the ground as shown in Figure 12. With this system, all drilling and sampling was contained within the conductor casing, isolating the work below the bridge deck from the Coyote Creek environment. The tub around the base of the conductor casing provided a secondary means of containment.

3.3 Soil Investigation

Once the conductor casing was seated to provide isolation of the drilling operation from the creek bed area, drilling commenced from the bridge above. The bridge work area is shown in Figure 13.

3.3.1 Sonic Drilling

Sonic drilling commenced and soil core samples were recovered in continuous increments of 10 feet. Soils recovered indicated clays from the surface down to approximately El. 23.3 ft. Below these clays was a 5 ½-foot thick layer of gravels and sands. A second layer of clay was then encountered between El. 13.6 ft and El. 17.8 ft (See boring log in Appendix A).

When drilling broke through the base of this second clay layer, the borehole experienced a temporary artesian condition which included out-gassing from the drill stem. The flow to the surface may have been caused by gas evolution, and therefore may not represent a true artesian condition. The top of the drill casing was at approximately El. 101.1 at the time the possible artesian condition was experienced, well above the ground surface at El. 63.3 feet. By the time the pressure bled off from this zone (escaping gas was no longer palpable from the top of the drill stem), approximately 20 to 25 gallons of groundwater and an unknown volume of odorless gas had issued from the top of the casing. The bulk of this groundwater was captured within the visqueen sheeting and spill booms placed on the bridge deck while the rest was captured within the lower tub around the casing at the ground surface below the bridge. Only minor amounts of dripping around the core hole edge occurred and were carried away by the wind, but the effects were not an issue. No reportable spills occurred.

Drilling below El. 17.8 ft encountered alternating deposits of sands, gravels, and clays. Sands and gravels appeared to either be clean or contain very minor amounts of silt. All wastes generated by the drilling process were captured and stored in IDW barrels for proper removal and disposal.

3.3.2 Samples and Core Storage

Continuous cores were collected during the sonic drilling, and were collected in plastic tube bags for examination, measurement, logging, and ease of placement into the wooden core boxes. Once the log had been completed, grab samples were collected from 24 locations along the core and sent for laboratory analysis.

Once grab samples had been collected and cataloged, the core boxes were transported off-site to the core storage facility. There were a total of 11 core boxes of core sample collected for BH-107.

3.3.3 Abandonment

Upon completion of the drilling at a terminal depth of 123.3 feet (El. -27.1), Santa Clara Valley Water District was notified and an inspector was scheduled for 9AM on Thursday, August 20 to be present at the start of grouting. Boart Longyear indicated that sand and material had boiled up into the hole approximately 12 feet. The driller re-drilled BH-107 and installed temporary casing to the terminal depth and charged the borehole casing with water to hold the borehole open overnight.

Thursday morning the drill crew began preparations for grouting. Approximately 8 feet of material had boiled up into the temporary casing overnight. The hole was open at El. -27.1 ft overnight and the water level had dropped from approximately El. 101 ft to El. 43.8 ft.

At 8:50AM the SCVWD inspector arrived, and grouting commenced at 9:15AM. The hole was initially tremmied filled with a volume of thick grout that would bring the level to the ground surface once the drill casing was removed from the hole. The water displaced from the borehole by the tremmied grout was captured in IDW barrels for disposal. When the casing was removed, the zone which had exhibited the temporary artesian pressure during drilling again began to out-gas but was not initially noted. The gas was odorless in nature. The grout level was initially measured at approximately El. 31.1 ft, indicating some grout loss to the formations below. The drillers planned to measure the level again in 30 minutes before topping the hole with grout.

The out-gassing in the hole created a foamed grout mixture which began to issue from the casing at the bridge deck (El. ~101 ft). The foam was captured within the upper and lower tubs around the casing, and was initially issuing at a rate of approximately 1 CFM. After 20 minutes, an additional 5 feet of casing was added, but by that time the pressure had again bled off and the condition abated. The grout level within the hole was then measured, and found to be at approximately El. 21 ft. Additional grout was mixed and tremmied into the borehole to bring the level to within 3 feet of the ground surface. After 30 minutes, the conductor casing was withdrawn from the hole. As the seal with the surrounding ground was broken, the water within the casing ran out into the lower tub where it was contained. No reportable spills occurred during this operation. The conductor casing was then withdrawn from the core hole in the bridge deck and the drill rig was demobilized. By this time the foamed grout contained within the upper tub had set and was easily removed.

Boart Longyear personnel manually mixed and added additional grout to the borehole, still within the containment tub on the ground beneath the bridge, to fill an additional 5 feet of the hole. Then, the stockpiled native material from the hand augering was used to fill the top 3 feet of the hole up to the original ground surface.

3.4 Site Cleanup and Restoration

After the hole had been backfilled to the surface and abandoned, the crew began cleanup of the site. The water and sandbags within the lower tub were removed. Sandbags were placed back onto pallets north of the bridge. The tub was then removed from the ponded area, and the area was restored using rakes under the oversight of the independent biologist.

Meanwhile, the support truck on the bridge was demobilized and the perimeter fencing around the north lane was removed from the bridge. A double lane closure was

established and the Terex crane truck was mobilized onto the bridge deck and set-up to hoist the pallets of sandbags from the ground below. The pallets were lifted and placed on a flat-bed truck. The crew also brought the surface tub up to the bridge deck and loaded it onto the flat-bed truck, along with the remaining unused IDW barrels. Both the flat-bed truck and crane truck then demobilized and left the site. The drill crew conducted a initial cleanup and restoration to the area below the bridge, the results of which are shown in Figure 14, placed the steel cover plate over the core hole in the bridge deck, and departed the site for the day. The north lane closure, still established by lane delineators and crash barrels, remained overnight so that the patching operations could begin early Friday morning.

On Friday, a final cleanup and restoration effort was made after the patch was installed. Both the initial and final cleanups and restorations of the site were observed by a biologist consultant to the VTA and found to adequately satisfy the environmental requirements set forth in the permits governing the work. No reportable spills occurred during the work. The City of San Jose has also found the restoration of their bridge satisfactory, and no further work is required.

3.5 Bridge Patching and Demobilization

On Friday, August 21, Penhall returned to the site to install the patch in the bridge deck. The lane closure and crash barrels had remained in place overnight. Seven barrels of IDW were removed from the site by Integrated Waste Management prior to the start of work.

Rebar reinforcement specified in drawing D300-CR-C172 (Figure 7) was tied and installed into the core hole and is shown installed in the core hole in Figure 15. A 2-foot square piece of plywood was hoisted by rope against the underside of the deck to provide a base form for the patch. Silicone sealant was placed on the board prior to hoisting to provide a seal against the deck to prevent leakage of patch material. The board was hung and secured against the base of the bridge deck by tie-wire connected to an additional piece of number 4 rebar resting across the overcore shelf of the core hole.

Penhall first mixed and filled the 8” diameter portion of the lower core hole with BASF Set 45 material. Over the next few minutes, a minor leak developed in the silicone bead and some material was lost below the bridge. A tarp installed in the ponded area caught all but a few drips of the leaking patch material, and within 10 minutes the initial set of the patch material had halted the leak. The independent biologist was notified and came to the site to recommend the appropriate measures to address the drips. Remediation in the form of raking the bottom of the ponded area affected by the drips was suggested by and implemented under the supervision of the independent biologist. No reportable spills occurred during patching.

The remaining portion of the patch was then backfilled with SET 45, and the uppermost 1” of the patch was given a darker tint using lamp black powder. This was done to better match the AC material on the surface of the bridge at the request of the City of San Jose. As shown in Figure 16, the material had very limited workability, and the smoothest

finish that could be achieved was implemented. The installation of the patch was completed at 10:10AM. The board was then removed from the base of the deck by pulling on attached ropes until it broke free from the tie-wire suspending it.

The bridge north lane, gutter, and sidewalks were swept clean, and residual SET 45 material was smeared over the PG&E marks that were made in permanent spray paint to fulfill the CSJ request that all markings on the sidewalk be removed. The remaining water soluble paint markings on the sidewalk were removed by wire brush. Crash barrels were demobilized from the site. Lane delineators were removed as well as the adhesive pads used to secure them to the AC pavement. A final check of the work area was made, and the lane was reopened to traffic at 12:35PM Friday afternoon, as shown in Figure 17.

3.6 Survey

Towill, Inc. conducted the as-built location survey of BH-107 on August 27, 2009. The survey was conducted at the bridge deck AC surface to confirm all depth readings measured from that elevation. The location is referenced to the California Coordinate System 1983 (CCS83) and the elevation references the North American Vertical Datum 1988 (NAVD88) in feet. The survey coordinates and elevation of BH-107 are as follows:

N 1,950,729.86 E 6,162,328.78 El. 96.22 ft.

4.0 Analysis and Interpretation

Upon completion of the fieldwork, analysis of soil and concrete samples and the conditions encountered during the work was completed.

4.1 Laboratory Testing

A total of twenty-four soil grab samples were collected from the core samples of BH-107 and subjected to laboratory testing. These sample locations are indicated in the boring log attached in Appendix A. Laboratory soil test results are summarized in Appendix B. In addition, the concrete core retrieved from the coring operation during the work was also subjected to strength testing. The soil testing was accomplished under the standards listed below.

- Soil Classification – ASTM D2487 and D2488
- Moisture Content – ASTM D2216
- Atterberg Limits – ASTM D4318
- Particle-Size Analysis – ASTM D 6913 and D 422

4.1.1 Cohesive Soils

Cohesive soils encountered within BH-107 were subjected to visual classification and standard index testing. Additionally, some samples were subjected to hydrometer and sieve analysis to provide grain size distributions.

The bulk of the cohesive soils present in BH-107 are CL based on the Unified Soils Classification System (USCS). A zone of moderately plastic clays was identified within the boring between El. 42.9 ft and El. 28.7 ft. All other cohesive soils encountered were of low plasticity. Although some samples indicated a higher silt fraction than clay based on hydrometer test results, their liquid limits and plastic indices classified them as low plasticity clays. Core materials identified in the field as dilatant silts (El. 57.2 and El. -21.4 ft) were classified as a clay, which should not exhibit dilatant characteristics.

Due to the use of the sonic drilling technique, retrieved cores were considered disturbed and therefore strength information was not reliable.

4.1.2 Non-Cohesive Soils

Non-cohesive soils encountered within BH-107 were also subjected to visual classification and standard index testing, including grain size analysis. Some hydrometer testing augmented these grain size analyses.

The results of the laboratory testing indicated a nearly even split of sands and gravels based on UCSC. The boring did not appear to encounter any materials containing grain sizes larger than coarse gravel. Gravels encountered in BH-107 are typically well-graded or clayey and contain up to 35% coarse gravel particles. All sand sized particles are well represented.

Six of the eleven non-cohesive soils sampled qualified as “clean” sands or gravels based on the low percentage passing the No. 200 sieve. Clean gravel was present in the zone which presented the potentially artesian condition. Although the zone which exhibited this temporary artesian condition is located below the tunnel horizon, clean sands and gravels are also present at the tunnel inverts of the currently planned 65% Engineering Design.

4.1.3 Coyote Creek Bridge Concrete

After the completion of the field work, compressive strength testing was conducted on the concrete core recovered from the Coyote Creek Bridge deck. This testing was conducted to help confirm the actual strength of the concrete in the bridge, which is over 90 years old, for the purpose of confirming the conservative strengths assumed in structural calculations, but also to aid the city in future assessments of the structure. Two compressive samples were prepared and subjected to testing from the core. The compressive strength of the specimens were 3,050 psi and 2,860 psi, with an average of 2,955 psi. This value is 20% higher than the strength assumed in the structural calculations contained in Appendix C.

4.2 Temporary Artesian Condition

The temporary artesian condition previously encountered in nearby borings was also encountered during the drilling of BH-107. Prior to the work, it was expected that the height of the casing above the ground surface would be more than adequate to counter this pressure. It was also expected that with the work being conducted in the late summer months (dry) that the condition would probably not exist. Both of these assumptions proved to be incorrect.

The fluid movement up the hole appears to have been driven, at least in part, by the gasses evolving from fluids in a shallow down-hole aquifer, located just below the tunnel horizon between El. 13.6 ft and El. -14.4 ft. Once confinement was released, the rising gasses expanded and promoted fluid movement above the casing elevation. The condition was temporary in nature during drilling, lasting only 20-30 minutes. However, after the inner casing was driven and left overnight, this upper aquifer appears to have been re-sealed and over the course of approximately 19 hours was able to recover and re-pressurize to the point that once the casing was pulled during grouting, the artesian condition manifested again. Despite the added weight of the thick grout mix tremmied into the hole prior to casing withdrawal, it does not appear that the temporary artesian condition was countered or even reduced. The additional unit weight of the tremmied grout, if the loss occurred in this formation, could have contributed the re-pressurization and displacement of additional groundwater into the borehole above. This cannot be confirmed by current information, therefore it should be assumed that the grout did not contribute to the second occurrence of temporary artesian conditions and that this layer is potentially capable of repeated artesian character across short recovery intervals.

4.3 Hydraulic Connection to Coyote Creek

The occurrence of the temporary, potentially artesian condition within BH-107, with temporary head in exceedance of El. 101 ft encountered in the sands and gravels below El. 13.4 ft, indicate that the sand and gravel layer below this elevation does not have any significant hydraulic connection with the Coyote Creek pool at El. 63.9 ft.

The overnight drop in borehole water levels from El. 101 ft to El. 43.8 ft, which was below the measured Coyote Creek pool at El. 63.9 ft, indicates that the sands and gravels at El. -27.1 are not hydraulically connected with Coyote Creek.

The re-occurrence of the temporary artesian condition at El. 13.6 ft upon pulling the temporary casing also indicates that the sand and gravel layer at El. -27.1 ft, which exhibited a hydraulic level of El. 43.8 ft overnight, are also not hydraulically connected.

4.4 Coyote Creek Bridge Structure

All work was successfully carried out on the bridge and equipment configurations were maintained within the parameters assumed in the structural load calculations conducted to check equipment loadings on the bridge, which are contained in Appendix C.

Additionally, no existing reinforcement within the bridge deck was damaged or penetrated by the coring operation, and the structural patch that was implemented is as shown in the as-built drawing of Figure 7 following the structural calculations also contained in Appendix C.

5.0 Conclusions and Recommendations

Due to the fact that neither the Geotechnical Data Report (GDR) nor the Geotechnical Baseline Report (GBR) will be updated during the current phase of the project, this report presents both factual information resulting from the drilling program (typically included in the GDR), along with interpretive information used for design purposes and for setting contractual geotechnical baselines for construction (typically contained in the GBR). Therefore, the information in this report relevant to each of those documents will be included in the future versions of both the GDR and GBR during the next phase of design.

The BH-107 drilling program at Coyote Creek was successfully completed and soil samples and data were obtained. The boring log confirms the continuity of the confining layer of cohesive soils beneath Coyote Creek that was encountered in adjacent borings.

Clean sands and gravels are present at this location at the invert level and below the planned tunnel invert elevation presented in the 65% design alignment. Below the confining layer in the sands and gravels, a possible artesian condition and out-gassing are present. The presence of this condition so close to the tunnel horizon could present issues for EPBM tunneling such as gas evolution in the excavation chamber. Additionally, the gas itself could pose a risk as it exits the screw conveyor into the tunnel environment. Further, the condition more specifically poses challenges and additional potential risks to the more exposed cross passage excavation and construction process. It is recommended that the previous memo, “Observed Upward Groundwater Flow and Flowing Artesian Conditions” written in 2005 (P0503-D300-TM-DE-016), be updated to incorporate the results of this investigation.

The sands and gravel aquifers present in borehole BH-107 do not appear to be hydraulically connected to the Coyote Creek water levels, and therefore present little risk of inflow originating from the creek provided ground movement resulting from tunnel excavation is minimal. However, should inadequate face pressure be maintained while tunneling near Coyote Creek, significant ground movement would present the possibility of establishing a hydraulic connection.

In addition to efforts to try to locate the source and nature of the degassing condition, the installation of relief wells is recommended for consideration in the final design phase to provide for the monitoring and release of trapped gasses below the confining layer near the tunnel horizon.

FIGURES

This page is intentionally left blank.

COYOTE CREEK SOIL INVESTIGATION

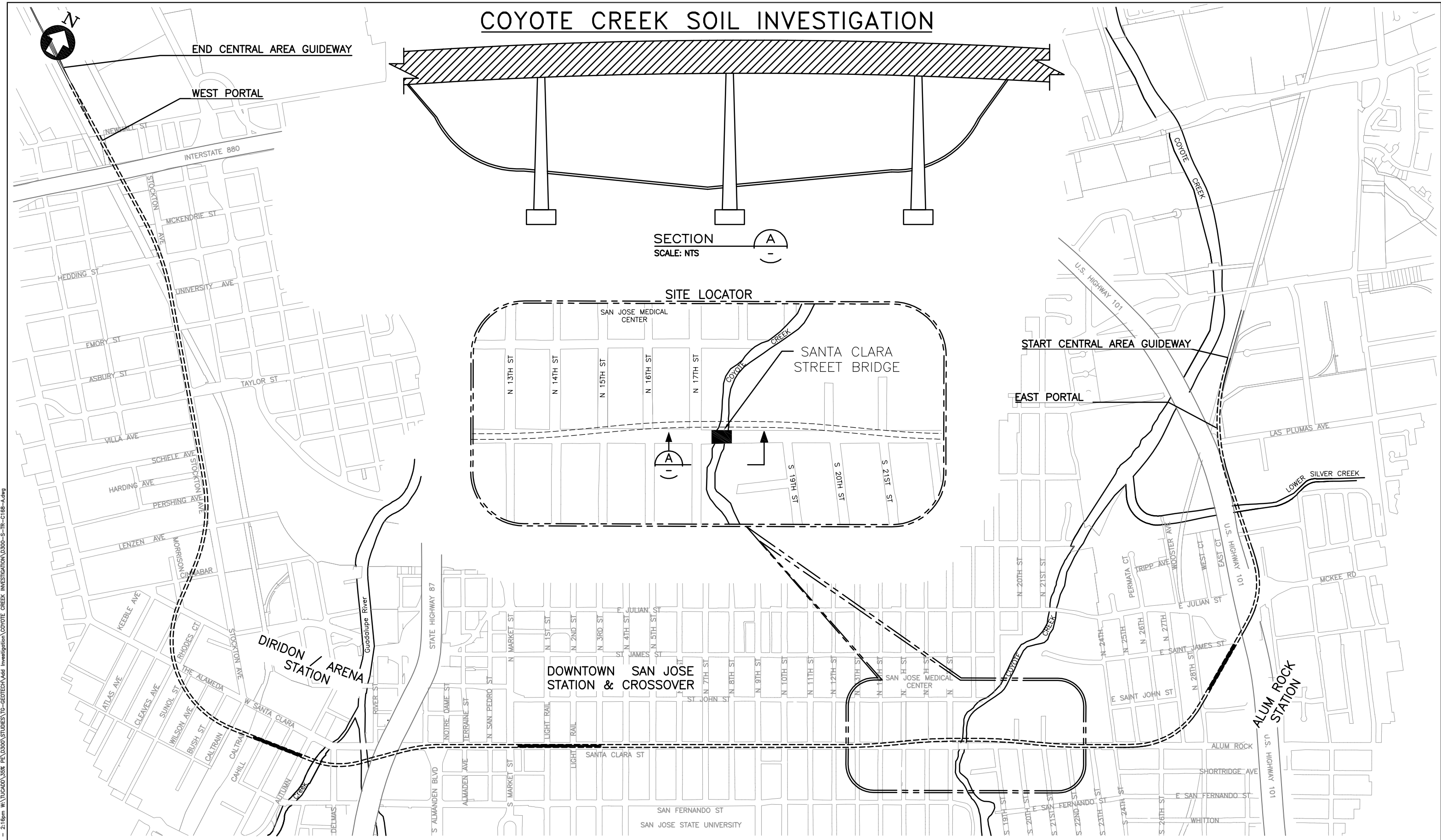

Jun 13, 2008 - 2:16pm W:\TUCAD01\3586_PEL\0300\STUDIES\TG-GEO\TRC\A\Investigation\COYOTE_CREEK_SOIL_INVESTIGATION\0300-S-TR-C168-A.dwg
 JOHNSON_H

REV	DATE	BY	SUB	APP	DESCRIPTION
A					FOR USE

DESIGNED BY H. JOHNSON
DRAWN BY H. JOHNSON
CHECKED BY T. HUNT
IN CHARGE A. LIU
DATE

HMM / BECHTEL
 A Joint Venture of **Hatch Mott MacDonald T&T, Inc.** and **Bechtel Infrastructure Corp.**

SUBMITTED _____ APPROVED _____

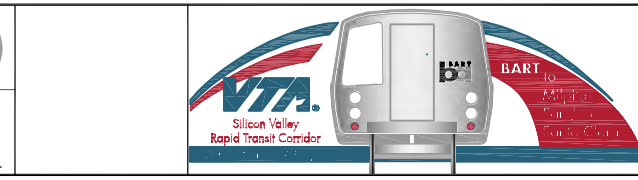

SILICON VALLEY RAPID TRANSIT PROJECT
 CENTRAL AREA GUIDEWAY
 COYOTE CREEK SOIL INVESTIGATION
 LOCATION MAP
 FIGURE 1 OF 8

CADD FILENAME D300-S-TR-C168-A.dwg
SIZE SCALE D NTS
CONTRACT NO. REV. D300 A
AREA CODE SHEET NO. PAGE NO. TR C168



Figure 2 – Photo of Planned BH-107 Location on Coyote Creek Bridge, Looking Southeast from north sidewalk, south end of Pier No. 3 located at joint in south guardrail.



Figure 3 – Photo of Planned BH-107 Location Below Coyote Creek Bridge, looking northwest, Pier No. 3 on the right. Photo shows vegetation prior to work.

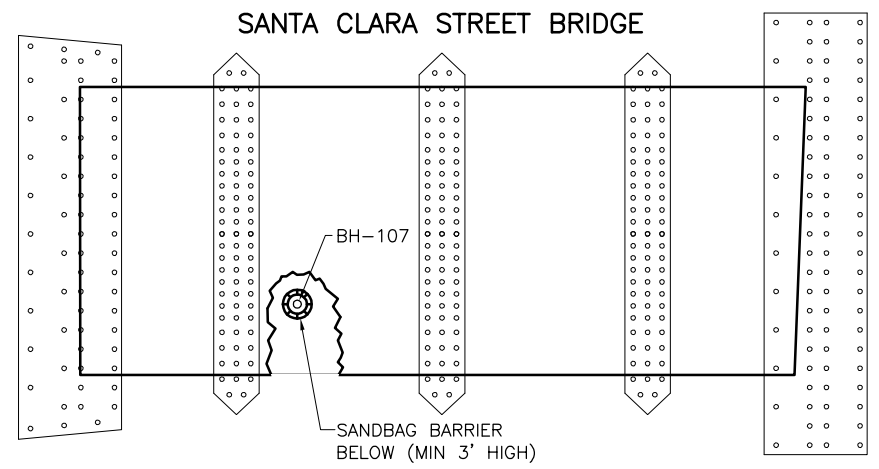

PLAN VIEW
SCALE: 1"=20'

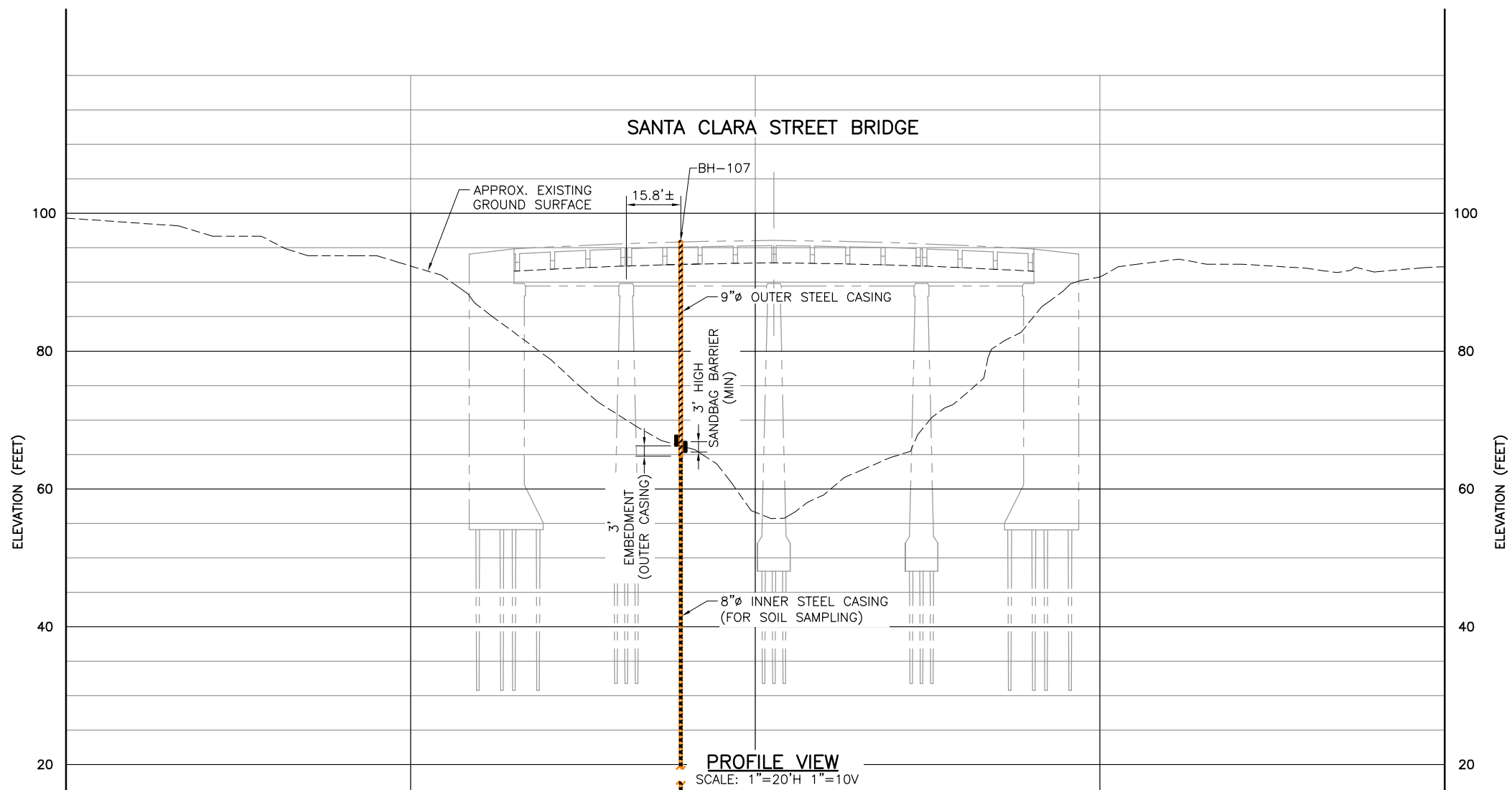

PROFILE VIEW
SCALE: 1"=20'H 1"=10'V

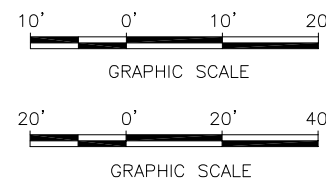

JOHNSON_H Jun 13, 2008 - 2:20pm W:\LOCAL\356\PE\0300\STUDIES\GEO\GEO\GEO\INVESTIGATION\COYOTE CREEK INVESTIGATION\0300-S-TR-C171-A.dwg

DESIGNED BY T. HUNT
DRAWN BY H. JOHNSON
CHECKED BY A. LIU
IN CHARGE A. LIU
DATE

REV	DATE	BY	SUB	APP	DESCRIPTION
A					FOR USE

HMM / BECHTEL
 A Joint Venture of **Hatch Mott MacDonald T&T, Inc.** and **Bechtel Infrastructure Corp.**

SUBMITTED _____ APPROVED _____



SILICON VALLEY RAPID TRANSIT PROJECT
CENTRAL AREA GUIDEWAY
 COYOTE CREEK SOIL INVESTIGATION
 CREEK PROTECTION/DIVERSION PLAN
 FIGURE 4 OF 8

CADD FILENAME D300-S-TR-C171-A		
SIZE SCALE D 1"=20'H 1"=10'V		
CONTRACT NO. D300	REV. A	
AREA CODE TR	SHEET NO. C171	PAGE NO.

SOIL TYPE:

- WELL-GRADED GRAVEL (GW)
- POORLY-GRADED GRAVEL (GP)
- WELL-GRADED GRAVEL WITH SILT (GW-GM)
- WELL-GRADED GRAVEL WITH CLAY (GW-GC)
- POORLY-GRADED GRAVEL WITH SILT (GP-GM)
- POORLY-GRADED GRAVEL WITH CLAY (GP-GC)
- CLAYEY GRAVEL (GC)
- SILTY GRAVEL (GM)
- SILTY, CLAYEY GRAVEL (GC-GM)
- WELL-GRADED SAND (SW)
- POORLY-GRADED SAND (SP)
- WELL-GRADED SAND WITH SILT (SW-SM)
- WELL-GRADED SAND WITH CLAY (SW-SC)
- POORLY-GRADED SAND WITH SILT (SP-SM)
- POORLY-GRADED SAND WITH CLAY (SP-SC)
- SILTY SAND (SM)
- CLAYEY SAND (SC)
- SILTY, CLAYEY SAND (SC-SM)
- SILTY SAND/SANDY SILT (SM-ML)
- CLAYEY SAND/LEAN CLAY (SC/CL)
- SILT (ML)
- LEAN CLAY (CL)
- SILTY CLAY (CL-ML)
- LOW PLASTICITY ORGANICS (OL)
- ELASTIC SILT (MH)
- FAT CLAY (CH)
- CLAY (CH-MH)
- HIGH PLASTICITY ORGANICS (OH)
- PAVEMENT WITH OR WITHOUT AGGREGATE BASE
- FILL
- NO DATA

SOIL BORING LITHOLOGY WITH UNDRAINED SHEAR STRENGTH (Su) EXAMPLE

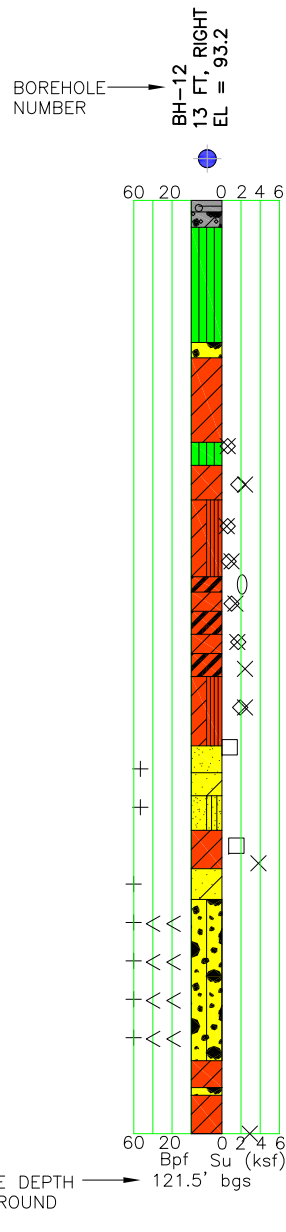

CPT SOUNDING WITH INTERPRETED LITHOLOGY AND UNDRAINED SHEAR STRENGTH (Su) EXAMPLE

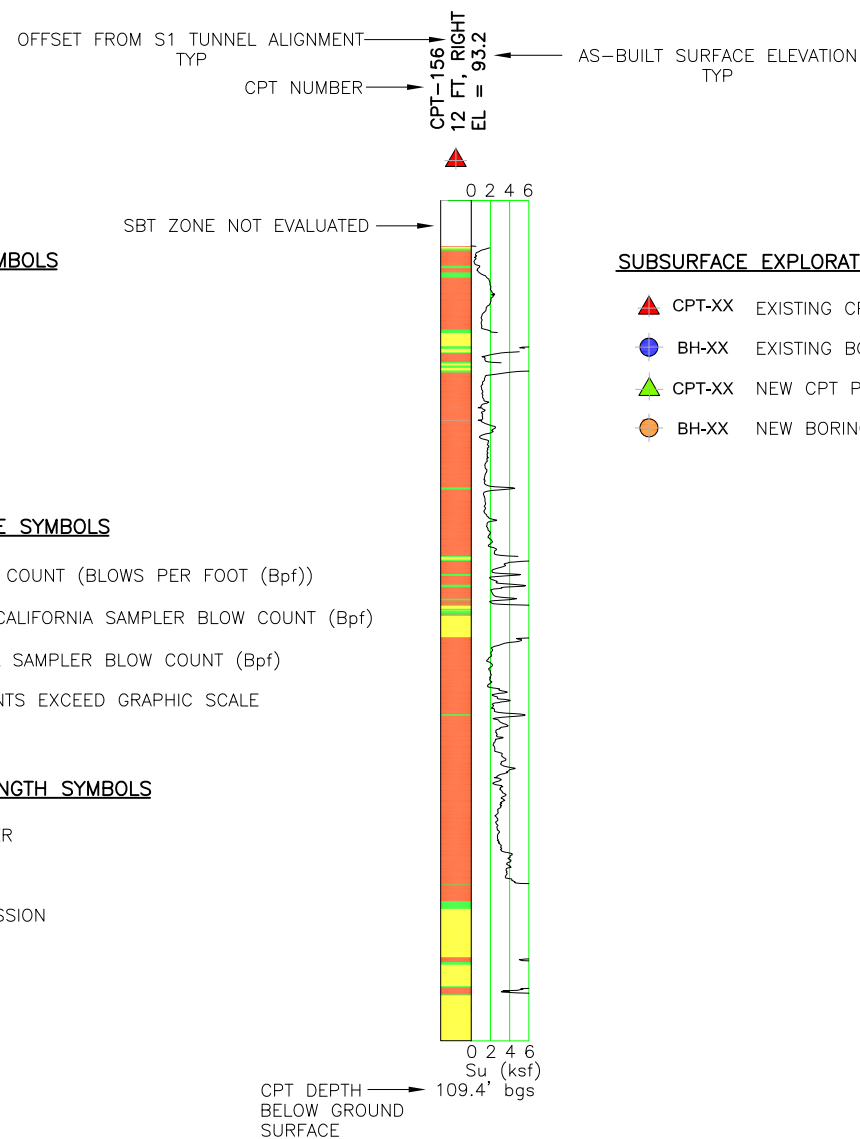

CLASSIFICATION TEST SYMBOLS

- γ = DRY DENSITY (pcf)
- ω = WATER CONTENT (%)
- LL = LIQUID LIMIT (%)
- PI = PLASTICITY INDEX (%)

PENETRATION RESISTANCE SYMBOLS

- + = MEASURED SPT BLOW COUNT (BLOWS PER FOOT (Bpf))
- \ominus = MEASURED MODIFIED CALIFORNIA SAMPLER BLOW COUNT (Bpf)
- ∇ = MEASURED CALIFORNIA SAMPLER BLOW COUNT (Bpf)
- << = INDICATES BLOW COUNTS EXCEED GRAPHIC SCALE

UNDRAINED SHEER STRENGTH SYMBOLS

- X = POCKET PENETROMETER
- \diamond = TORVANE
- \square = UNCONFINED COMPRESSION
- \emptyset = FIELD VANE
- \bigcirc = MINI VANE

SUBSURFACE EXPLORATIONS

- CPT-XX EXISTING CPT PHASE 1
- BH-XX EXISTING BORING PHASE 1
- CPT-XX NEW CPT PHASE 2
- BH-XX NEW BORING PHASE 2

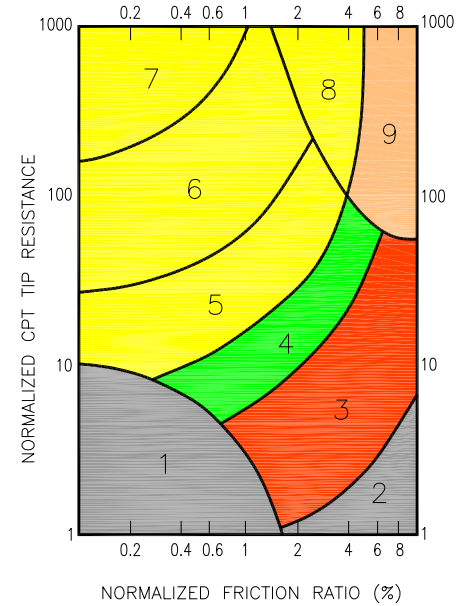

ZONE	SOIL BEHAVIOR TYPE (SBT)
1	SENSITIVE FINE-GRAINED
2	ORGANIC MATERIAL
3	CLAY TO SILTY CLAY
4	CLAYEY SILT TO SILTY CLAY
5	SILTY SAND TO SANDY SILT
6	CLEAN SANDS TO SILTY SANDS
7	GRAVELLY SAND TO SAND
8	VERY STIFF SAND TO CLAYEY SAND*
9	VERY STIFF FINE-GRAINED*

*OVERCONSOLIDATED OR CEMENTED

CPT CORRELATION CHART (MODIFIED FROM ROBERTSON, 1990)

LEGEND

- EXISTING GROUND SURFACE
- TUNNEL EXTENTS
- TUNNEL SPRINGLINE
- EXCAVATION BOUNDARIES

NOTES:

1. STATIONING AND PROFILE ARE RELATIVE TO S1 TUNNEL ALIGNMENT DATED APRIL 25, 2008.
2. ELEVATIONS ARE BASED ON 1988 NAVD.
3. MAXIMUM UNDRAINED SHEAR STRENGTH CAPACITY OF FIELD VANE IS ~ 2.0 ksf.
4. MAXIMUM UNDRAINED SHEAR STRENGTH CAPACITY OF POCKET PENETROMETER IS 4.5 ksf.
5. MAXIMUM UNDRAINED SHEAR STRENGTH CAPACITY OF TORVANE IS ~ 2.0 ksf.
6. CPT UNDRAINED SHEAR STRENGTH VALUES TRUNCATED AT 6.0 ksf.
7. CPT UNDRAINED SHEAR STRENGTH NOT APPLICABLE FOR SBT ZONES 5, 6, 7, AND 8, HENCE NOT SHOWN.
8. BORING LOGS FOR BH-83, BH-86, BH-92, BH-94, BH-96 AND BH-104 ARE INCLUDED IN PUMPING TEST DATA REPORT (HMM/BECHTEL, FEBRUARY 2008).
9. FOR BORINGS BH-24, BH-52, BH-58, BH-70 AND BH-74, CLASSIFICATION TEST RESULTS ARE NOT SHOWN AT CORRECT DEPTHS. REFER TO BORING LOGS IN APPENDIX 1 OF THIS PHASE TWO - 65% ENGINEERING DESIGN INVESTIGATION GEOTECHNICAL DATA REPORT.

VILLEGAS_R May 09, 2008 - 9:59am W:\TU\CD\035% PE\0300\STUDIES\TC-GEO\TECH\DRWING\0300-S-TC-C001-A.dwg

REV	DATE	BY	SUB	APP	DESCRIPTION
0	20080429				FOR USE

DESIGNED BY A. JAIN
DRAWN BY R. VILLEGAS
CHECKED BY A. LIU
IN CHARGE A. LIU
DATE 20080429

HMM / BECHTEL

A Joint Venture of Hatch Mott MacDonald T&T, Inc. and Bechtel Infrastructure Corp.

SUBMITTED _____ APPROVED _____



SILICON VALLEY RAPID TRANSIT PROJECT
CENTRAL AREA GUIDEWAY
 GEOTECHNICAL PLAN AND PROFILE
 LEGEND

CADD FILENAME D300-S-TG-C001-A.dwg			
SIZE B	SCALE NTS		
CONTRACT NO. D300	SHEET NO. 5-1	REV. A	PAGE NO.

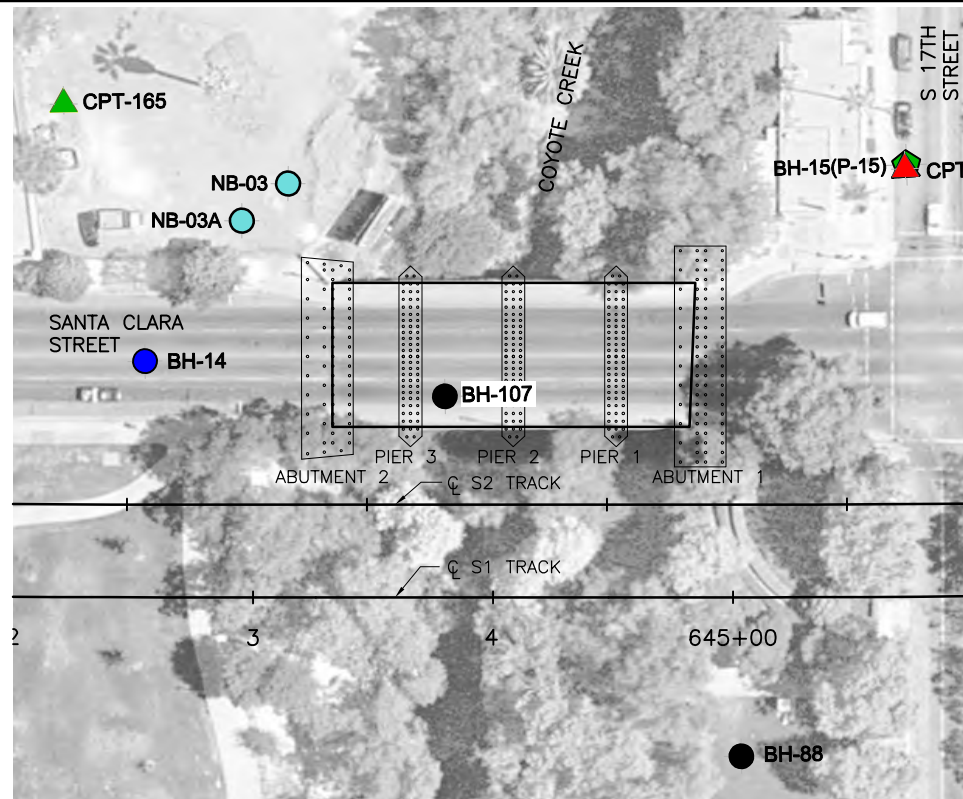

PLAN

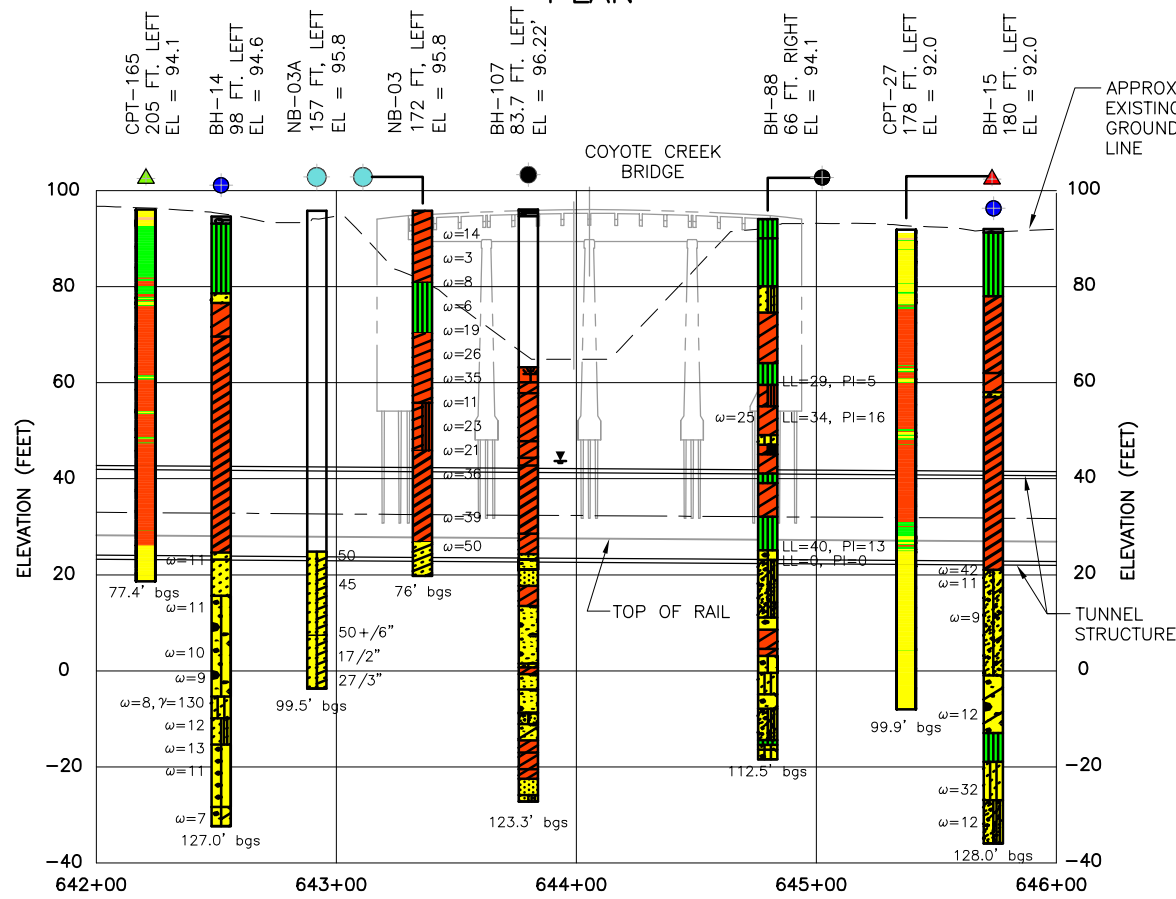

PROFILE

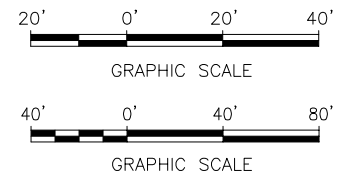

Oct 13, 2009 4:07pm W:\TUODAD\358 PE\STUDIES\TC-GEOTECH\Add Investigation\COYOTE CREEK INVESTIGATION\20090817 Boring 107\0300-S-TR-C169-B.dwg

REV	DATE	BY	SUB	APP	DESCRIPTION
B	20090915				BH-107 AS-BUILT
A					FOR USE

DESIGNED BY T HUNT
DRAWN BY H JOHNSON
CHECKED BY ALIU
IN CHARGE ALIU
DATE

HMM / BECHTEL
 A Joint Venture of **Hatch Mott MacDonald T&T, Inc.** and **Bechtel Infrastructure Corp.**

SUBMITTED _____ APPROVED _____



SILICON VALLEY RAPID TRANSIT PROJECT
CENTRAL AREA GUIDEWAY
 COYOTE CREEK SOIL INVESTIGATION
 PLAN AND PROFILE
 BH-107

CADD FILENAME D300-S-TR-C169-B		
SIZE SCALE D 1"=40'H; 1"=20'V		
CONTRACT NO. D300	REV. B	
AREA CODE TR	SHEET NO. C169	PAGE NO.

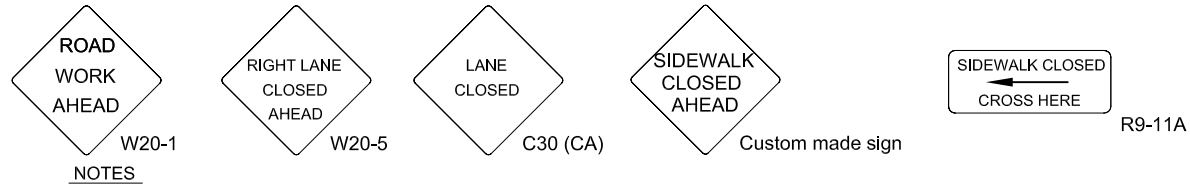

LEGEND

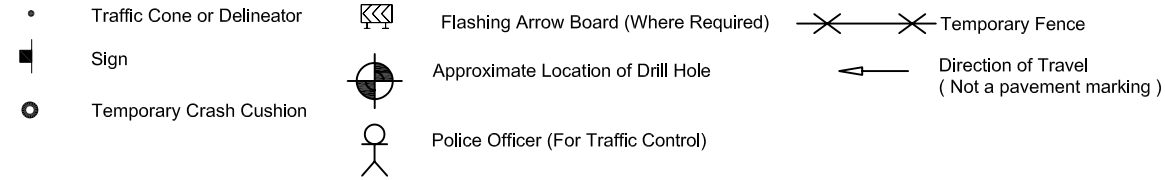

DETAILS ON TEMPORARY CRASH CUSHION, SAND FILLED

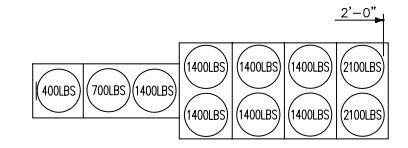

NOTES
1) Police officers required (2 min.)
2) All Dimenions are in feet

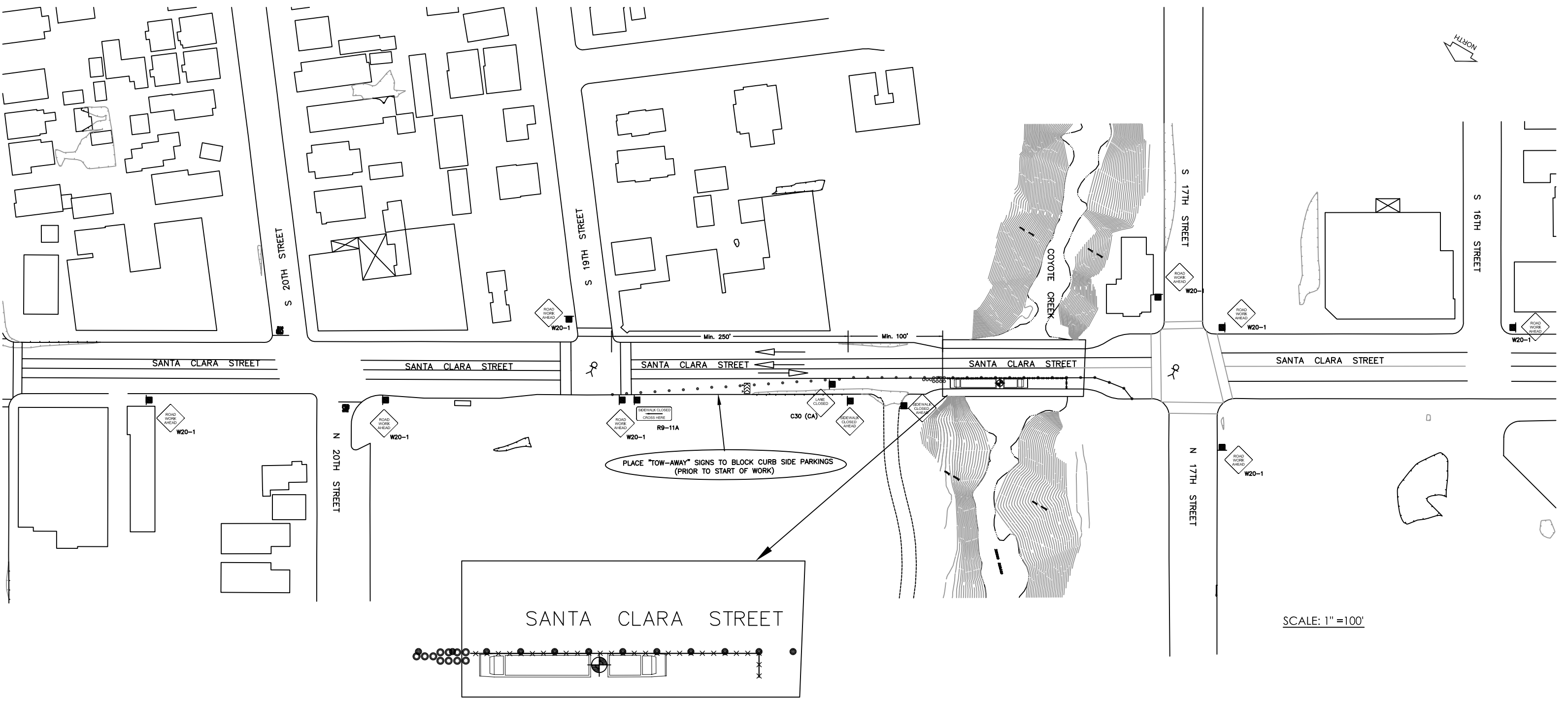

NOT TO SCALE

CITY ENCROACHMENT # 3-07004RU

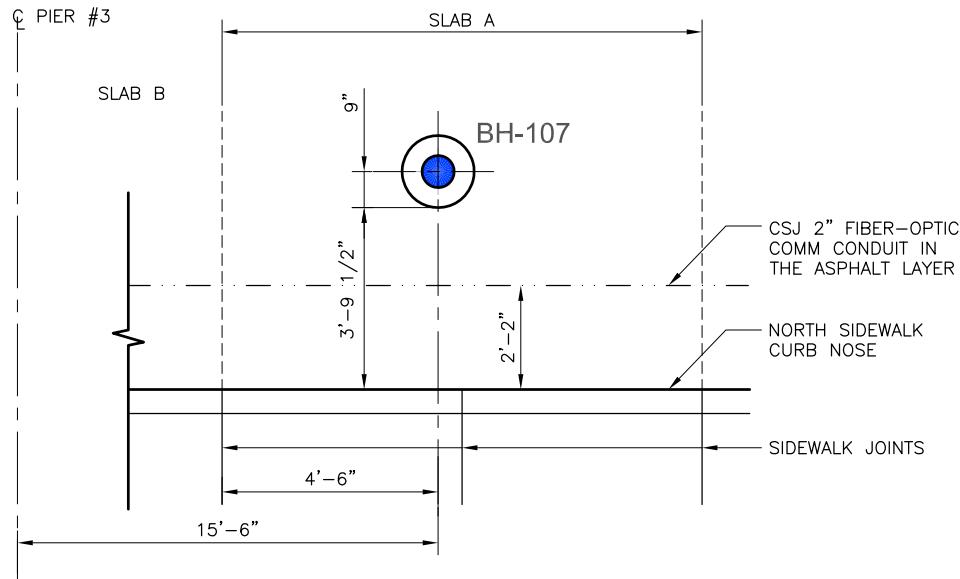

LOCATION PLAN
SCALE: NTS

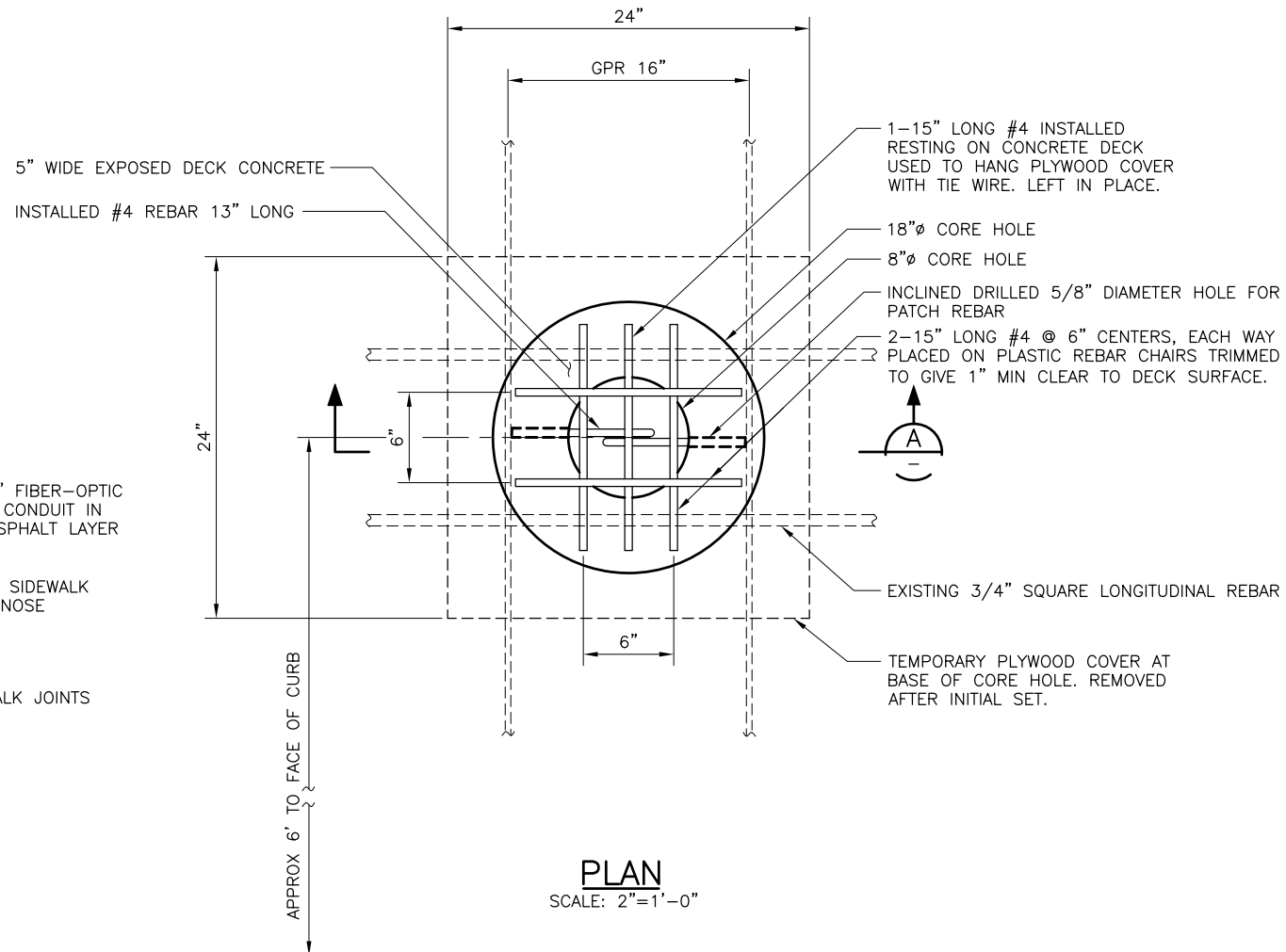

PLAN
SCALE: 2"=1'-0"

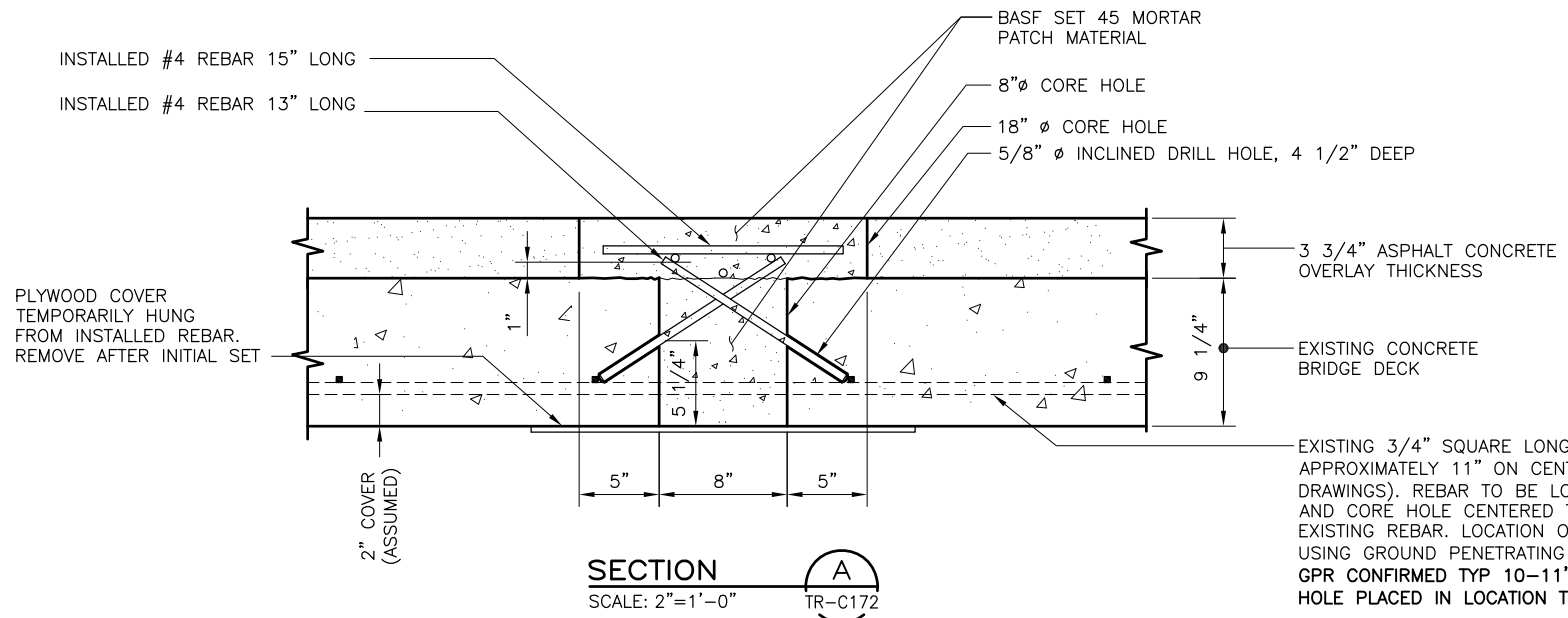

SECTION
SCALE: 2"=1'-0"
A
TR-C172

NOTES AND SPECIFICATIONS:

- PATCHING FOR BACK FILLING OF CORE DRILLED HOLES SHALL BE BASF SET 45 CHEMICAL ACTION MORTAR, ACHIEVING 5000 PSI WITHIN 3 HOURS.
- 8" DIAMETER CORE DRILLED FOR BOREHOLE.
- 18" DIAMETER CORE DRILLED FOR TOP HALF OF HOLE THROUGH ASPHALTIC CONCRETE.
- NO CONCRETE OR DEBRIS SHALL BE ALLOWED TO FALL INTO COYOTE CREEK.

CONSTRUCTION SEQUENCES:

- DETECT THE LOCATION OF EXISTING EMBEDDED REBAR USING GROUND PENETRATING RADAR (GPR) WITHIN 24" OF THE DEFINED CENTER COORDINATES OF BOREHOLE.
- ADJUST CENTER OF CORE HOLE TO AVOID CORING THROUGH EXISTING REBAR.
- DRILL 18" DIAMETER CORE THROUGH FULL DEPTH OF ASPHALTIC CONCRETE AND TERMINATE AT TOP OF CONCRETE BRIDGE DECK.
- DRILL 8" DIAMETER CORE HOLE THROUGH ENTIRE THICKNESS.
- DRILL 5/8" DIAMETER HOLE AT FLATTEST ANGLE POSSIBLE INTO THE LOWER COREHOLE SIDE WALL CENTERED 5 1/4" UP FROM THE BASE OF THE BRIDGE DECK. TWO HOLES ARE REQUIRED, AND MUST ONLY BE DRILLED AT EITHER THE TRANSVERSE OR LONGITUDINAL CARDINAL POINTS OF THE HOLE FOR INTERNAL REBAR CLEARANCE. DRILL HOLE DEPTH SHALL BE BETWEEN 4" AND 4 1/2" MEASURED FROM THE LOWER LIP OF THE DRILLED HOLE.
- INSERT 8" NOMINAL STEEL CASING FOR DRILLING, TO BE PERFORMED WITHIN A CLOSED SYSTEM.
- PERFORM SOIL INVESTIGATION.
- INSTALL A 13" LONG #4 REBAR DOWEL INTO EACH DRILLED HOLE.
- INSTALL TEMPORARY PLYWOOD COVER AGAINST UNDERSIDE OF BRIDGE DECK AND HANG WITH WIRE FROM INSTALLED CROSSING REBAR. BOARD SHALL BE INSTALLED WITH SEALANT TO PREVENT LEAKAGE DURING PATCHING OPERATION.
- PATCH THE CORED HOLE WITH BASF SET 45 5000 PSI MORTAR, TOP 1" TINTED WITH LAMP BLACK POWDER ADDITIVE TO MATCH BRIDGE ASPHALT COLOR. REOPEN TO TRAFFIC AFTER 1 HOUR.

CORED 2009/08/17
PATCHED 2009/08/21

AS-BUILT DRAWING



Sep 16, 2009 11:35am W:\TUCADD\35% PE\STUDIES\10-GEOTECH\Add Investigation\COYOTE CREEK INVESTIGATION\20090817 Boring 107\0300-S-TR-C172-B.dwg

REV	DATE	BY	SUB	APP	DESCRIPTION
B	20090825				AS-BUILT
A	20090813				FOR USE

DESIGNED BY
I. ISAACSON
DRAWN BY
M. WHITE
CHECKED BY
A. MILLER
IN CHARGE
C. WU
DATE
20090916



HMM / BECHTEL
A Joint Venture of Hatch Mott MacDonald T&T, Inc. and Bechtel Infrastructure Corp.

SUBMITTED _____ APPROVED _____



SILICON VALLEY RAPID TRANSIT PROJECT
CENTRAL AREA GUIDEWAY

COYOTE CREEK SOIL INVESTIGATION
BRIDGE CORING AND RESTORATION PLAN

CADD FILENAME D300-S-TR-C172-B.dwg		
SIZE	SCALE	
D	2"=1'-0"	
CONTRACT NO.	D300	REV. B
AREA CODE	TR	SHEET NO. C172
		PAGE NO.



Figure 8 – Photo of Marked Deck Reinforcement Locations. GPR equipment in background. Photo taken from north curb looking south.



Figure 9 – Photo of bridge inspection truck. BH-107 is located under the aft of the inspection truck. Access to the base of the deck could not be achieved with this equipment.



Figure 10 – Photo of Completed Core Hole Through Bridge Deck



Figure 11 – Photo of Sand Bag Crane Operation. Sand bags being landed on north side of bridge between Pier Nos. 2 and 3.



Figure 12 – Photo of Conductor Casing and Isolation Tub with Sandbags at Ground Surface. Pier No. 3 is on the right, Pier No. 2 on the left. The photo is looking northwest.



Figure 13 – Photo of Drilling Operation on Bridge Deck. Photo is looking southwest.



Figure 14 – Photo of Restored Work Area Beneath Bridge. Stinging Nettles in landing area have been flattened by sandbag pallets. Pier No. 3 to right, photo is looking northwest.



Figure 15 – Photo of Patch Reinforcement. Form board is shown below core hole.



Figure 16 – Photo of Installed Patch. BASF Set 45 material had limited workability.



Figure 17 – Photo of Completed and Restored Bridge After Work Completion.
Photo looks southwest.

APPENDIX A

BH-107 Boring Log

This page is intentionally left blank.

ELEVATION, ft	DEPTH, ft	MATERIAL SYMBOL	SAMPLE NO. RECOVERY (in)	SAMPLER TYPE	SAMPLER BLOW COUNT/ PRESSURE, psi	LOCATION: Coyote Creek Bridge at Santa Clara St, 4'7" South of North curbline, 15'6" West of Pier #3 centerline. N 1,950,729.86 E 6,162,328.78 SURFACE EL: 96.2 ft (NAVD88 datum)	DRY UNIT WEIGHT, pcf	WATER CONTENT, %	% PASSING #200 SIEVE	LIQUID LIMIT, %	PLASTICITY INDEX (%)	UNDRAINED SHEAR STRENGTH, S _u , ksf	OTHER TESTS
						MATERIAL DESCRIPTION							
	95					3.75 inch thick ASPHALT CONCRETE Overlay --18 inch inside diameter corehole							
	5					--Concrete Bridge Deck: 9.25 inch thick concrete bridge deck - slab A --8 inch inside diameter corehole							
	90					--Airspace below bridge deck							
	10												
	85												
	15												
	80												
	20												
	75												
	25												
	70												
	30												
	65					∇ --Water surface of Coyote Creek							
	35					ORGANIC CLAY WITH SILT (OL), black, wet, with trash and vegetation debris --Hand auger below creek bed							
	60					LEAN CLAY (CL), olive brown, moist --Hand auger to 37.9 feet below ground surface	25	89	41	18			
	40		1	24.8'		LEAN CLAY (CL), olive gray, some silt, dilatant							
	55						30		35	12			
	45												
	50					--trace fine sand at 47.3 feet bgs, increasing sand content with depth	23	74	27	7			

SONIC BOR LOG - POST 65% PHASE E:\SVRT GINT FILES\SVRT PHASE2.GPJ TEST LIBRARY-DOWNTOWN_PARIKH_01_02_08.GLB 9/11/09 03:27 p

BORING DEPTH: 123.3 ft
 DEPTH TO WATER: 52.4 ft., 8/20/09, overnight hole open at EL -27.1 ft
 BACKFILL: Bentonite Grout
 START DATE: August 19, 2009
 COMPLETION DATE: August 20, 2009
 NOTES: 1. See Legend Sheet for terms and symbols.

DRILLING METHOD: 4-in. dia. Continuous Core
 RIG TYPE: Boart Longyear PS Sonic
 DRILLED BY: Boart Longyear, D. Ostenberg
 LOGGED BY: J. Isaacson

2. Groundwater levels measured at the time of drilling may not be representative of actual groundwater conditions and should not be used for design purposes. For applicable groundwater information, please refer to piezometer and observation well data.

LOG OF BORING NO. BH-107

ELEVATION, ft	DEPTH, ft	MATERIAL SYMBOL	SAMPLE NO. RECOVERY (in)	SAMPLER TYPE	SAMPLER BLOW COUNT/PRESSURE, psi	LOCATION: Coyote Creek Bridge at Santa Clara St. 4'7" South of North curbline, 15'6" West of Pier #3 centerline. N 1,950,729.86 E 6,162,328.78 SURFACE EL: 96.2 ft (NAVD88 datum)	DRY UNIT WEIGHT, pcf	WATER CONTENT, %	% PASSING #200 SIEVE	LIQUID LIMIT, %	PLASTICITY INDEX (%)	UNDRAINED SHEAR STRENGTH, S _u , ksf	OTHER TESTS
						MATERIAL DESCRIPTION							
	45					LEAN CLAY WITH SAND (CL), olive to olive brown and olive gray, fine sand --silty fine sand, olive gray, between 50.6 and 50.8 feet		28	79	29	9		
	55					SANDY LEAN CLAY (CL), olive gray, moist		37	100	59	30		
	40					FAT CLAY (CH), gray to olive gray, moist, medium plastic							
	60		3	120"									
	35							33		55	29		
	65												
	30												
	70		4	120"		LEAN CLAY (CL), buff brown, moist, trace medium and coarse sand, low plasticity --mottled buff/dark gray, increasing sand content with depth		33		49	23		
	25					CLAYEY SAND (SC), buff brown/dark gray		28	81	36	16		
	75					WELL-GRADED GRAVEL WITH SAND (GW), wet, fine to coarse sand and fine gravel --silt content decreasing with depth		12	28				
	20					POORLY-GRADED SAND (SP), medium to coarse		6	3				
	80		5	120"		SANDY LEAN CLAY (CL), olive gray, moist, fine to medium sand		7	1				
	15							22	63	42	19		
	85					WELL-GRADED GRAVEL WITH SAND (GW), moist, fine to coarse, trace silt --temporary artesian and outgassing layer --grain size increasing with depth --fine to medium, silty		5	3				
	10												
	90		6	120"				4	2				
	5												
	95					POORLY-GRADED GRAVEL WITH CLAY AND SAND (GP-GC), wet, medium to coarse sand, fine gravel, trace silt		6	6				
	0					SANDY LEAN CLAY (CL), tan brown, mottled gray, moist, trace silt		21	59	32	14		

SONIC BOR LOG - POST 65% PHASE E:\SVRT GINT FILES\SVRT PHASE2.GPJ TEST LIBRARY-DOWNTOWN_PARIKH_01_02_08.GLB 9/11/09 03:27 p

BORING DEPTH: 123.3 ft
 DEPTH TO WATER: 52.4 ft., 8/20/09, overnight hole open at EL -27.1 ft
 BACKFILL: Bentonite Grout
 START DATE: August 19, 2009
 COMPLETION DATE: August 20, 2009
 NOTES: 1. See Legend Sheet for terms and symbols.

Continued

DRILLING METHOD: 4-in. dia. Continuous Core
 RIG TYPE: Boart Longyear PS Sonic
 DRILLED BY: Boart Longyear, D. Ostenberg
 LOGGED BY: J. Isaacson

2. Groundwater levels measured at the time of drilling may not be representative of actual groundwater conditions and should not be used for design purposes. For applicable groundwater information, please refer to piezometer and observation well data.

LOG OF BORING NO. BH-107

ELEVATION, ft DEPTH, ft	MATERIAL SYMBOL	SAMPLE NO. RECOVERY (in)	SAMPLER TYPE	SAMPLER BLOW COUNT/ PRESSURE, psi	LOCATION: Coyote Creek Bridge at Santa Clara St. 4'7" South of North curbline, 15'6" West of Pier #3 centerline. N 1,950,729.86 E 6,162,328.78 SURFACE EL: 96.2 ft (NAVD88 datum)	DRY UNIT WEIGHT, pcf	WATER CONTENT, %	% PASSING #200 SIEVE	LIQUID LIMIT, %	PLASTICITY INDEX (%)	UNDRAINED SHEAR STRENGTH, S _u , ksf	OTHER TESTS
					MATERIAL DESCRIPTION							
-5	[Symbol: Well-graded gravel with sand]				WELL-GRADED GRAVEL WITH SAND (GW), wet, with medium to coarse sand, subangular to subrounded medium to coarse gravel, trace silt		5	2				
105	[Symbol: Well-graded gravel]				WELL-GRADED GRAVEL (GW), wet, some fine to coarse sand, trace to some silt							
-10	[Symbol: Poorly-graded sand with gravel]				POORLY-GRADED SAND WITH GRAVEL (SP), wet, fine to medium gravel		7	6				
110	[Symbol: Well-graded sand with clay and gravel]	8 120"			WELL-GRADED SAND WITH CLAY AND GRAVEL (SW-SC), wet, medium to coarse sand, fine to medium gravel, trace silt							
-15	[Symbol: Clayey gravel with sand]				CLAYEY GRAVEL WITH SAND (GC), brown, moist to wet, well-graded fine to coarse sand, some silt		27	32	11			
115	[Symbol: Lean clay with gravel]				LEAN CLAY WITH GRAVEL (CL), olive gray, moist, fine to medium gravel		25	95	36	13		
-20	[Symbol: Lean clay]				LEAN CLAY (CL), buff brown, moist, very fine sand --gray/brown mottled		22		30	9		
120	[Symbol: Sandy lean clay]	9 60"			SANDY LEAN CLAY (CL), buff brown, moist, fine sand, with some silt		13	4				
-25	[Symbol: Poorly-graded sand with gravel]				POORLY-GRADED SAND WITH GRAVEL (SP), fine to coarse, fine subrounded gravel, trace silt --increasing silt content with depth		12	8				
125	[Symbol: Poorly-graded sand with silt and gravel]				POORLY-GRADED SAND WITH SILT AND GRAVEL (SP-SM), coarse, fine subrounded gravel, trace silt							
-30												
130												
-35												
135												
-40												
140												
-45												
145												
-50												

SONIC BOR LOG - POST 65% PHASE E:\SVRT GINT FILES\SVRT PHASE2.GPJ TEST LIBRARY-DOWNTOWN_PARIKH_01_02_08.GLB 9/11/09 03:27 p

BORING DEPTH: 123.3 ft
 DEPTH TO WATER: 52.4 ft., 8/20/09, overnight hole open at EL -27.1 ft
 BACKFILL: Bentonite Grout
 START DATE: August 19, 2009
 COMPLETION DATE: August 20, 2009
 NOTES: 1. See Legend Sheet for terms and symbols.

DRILLING METHOD: 4-in. dia. Continuous Core
 RIG TYPE: Boart Longyear PS Sonic
 DRILLED BY: Boart Longyear, D. Ostenberg
 LOGGED BY: J. Isaacson

2. Groundwater levels measured at the time of drilling may not be representative of actual groundwater conditions and should not be used for design purposes. For applicable groundwater information, please refer to piezometer and observation well data.

LOG OF BORING NO. BH-107

APPENDIX B

BH-107 Laboratory Soil Test Results

This page is intentionally left blank.

PLASTICITY INDEX

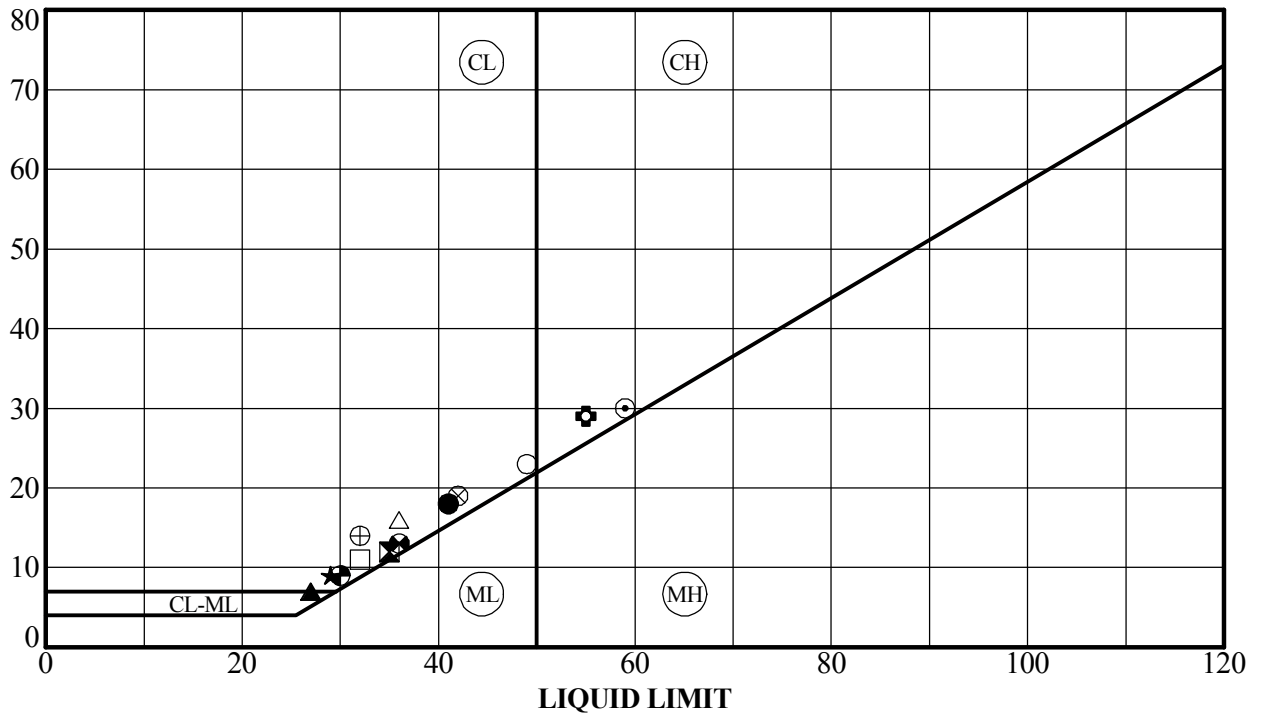

Key Symbol	Boring No.	Depth (Feet)	Liquid Limit (%)	Plasticity Index (%)	Liquidity Index	Water Content (%)	% Passing #200 Sieve	USCS
●	BH-107	37.8	41	18	0.100	25		CL
⊠	BH-107	42.0	35	12	0.542	30		CL
▲	BH-107	47.5	27	7	0.400	23		CL
★	BH-107	52.3	29	9	0.933	28		CL
⊙	BH-107	54.3	59	30	0.263	37		CH
⊕	BH-107	62.1	55	29	0.228	33		CH
○	BH-107	67.8	49	23	0.296	33		CL
△	BH-107	70.1	36	16	0.500	28		CL
⊗	BH-107	79.5	42	19	-0.037	22		CL
⊕	BH-107	95.9	32	14	0.221	21		CL
□	BH-107	112.0	32	11	0.545	27		CL
⊗	BH-107	114.6	36	13	0.169	25		CL
⊕	BH-107	117.6	30	9	0.156	22		CL

ATTERBERG LIMITS - SVRT POST-65% PHASE SVRT PHASE2.GPJ SVRT-BART.GDT 9/11/09



PREP'D BY:
A. Jain
APP'D BY:

DATE:
9/11/09
DWG FILE:

PLASTICITY CHART AND DATA

SVRT DOWNTOWN
San Jose, California

FIGURE

PROJECT No.
213213JH02

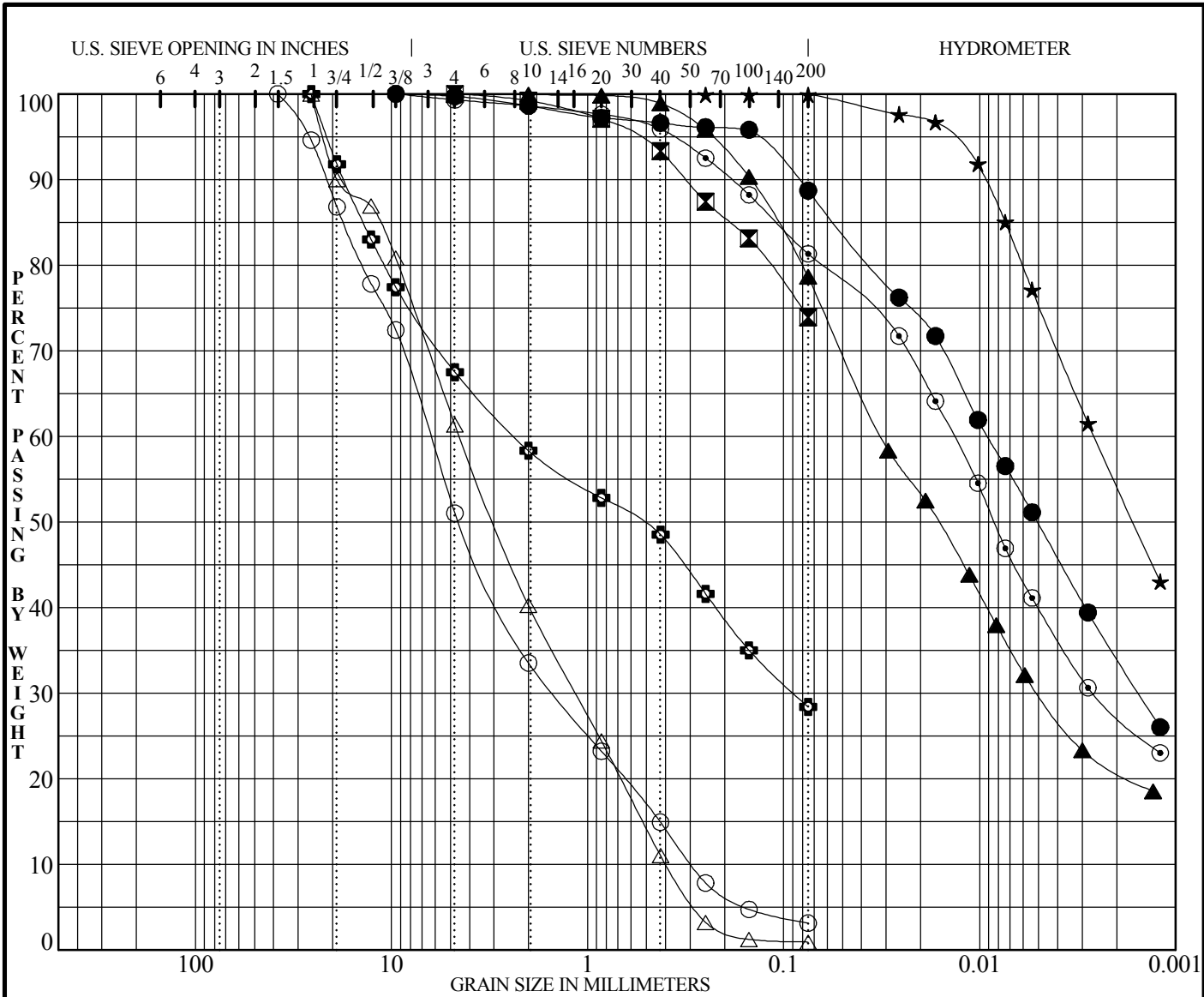

Cobbles	Gravel		Sand			Silt and Clay
	Coarse	Fine	Coarse	Medium	Fine	

Key Symbol	Boring No.	Depth (Feet)	% Passing No. 200 Sieve	% Passing No. 4 Sieve	Sample Description	USCS
●	BH-107	37.8	89	100	Lean CLAY (CL)	CL
⊠	BH-107	47.5	74	100	Lean CLAY with sand (CL)	CL
▲	BH-107	52.3	79	100	Sandy Lean CLAY (CL)	CL
★	BH-107	54.3	100	100	Fat CLAY (CH)	CH
⊙	BH-107	70.1	81	99	Lean CLAY (CL)	CL
⊕	BH-107	72.7	28	68	Clayey SAND with gravel (SC)	SC
○	BH-107	74.3	3	51	Well-graded GRAVEL with sand (GW)	GW
△	BH-107	76.4	1	61	Poorly-graded SAND with gravel (SP)	SP

GRAIN SIZE - SVRT POST-65% PHASE SVRT PHASE2.GPJ SVRT-BART.GDT 9/11/09

	PREP'D BY: A. Jain	GRADATION TEST DATA	FIGURE
	APP'D BY:		
	DATE: 9/11/09	SVRT DOWNTOWN	
	DWG FILE:	San Jose, California	
			PROJECT No. 213213JH02

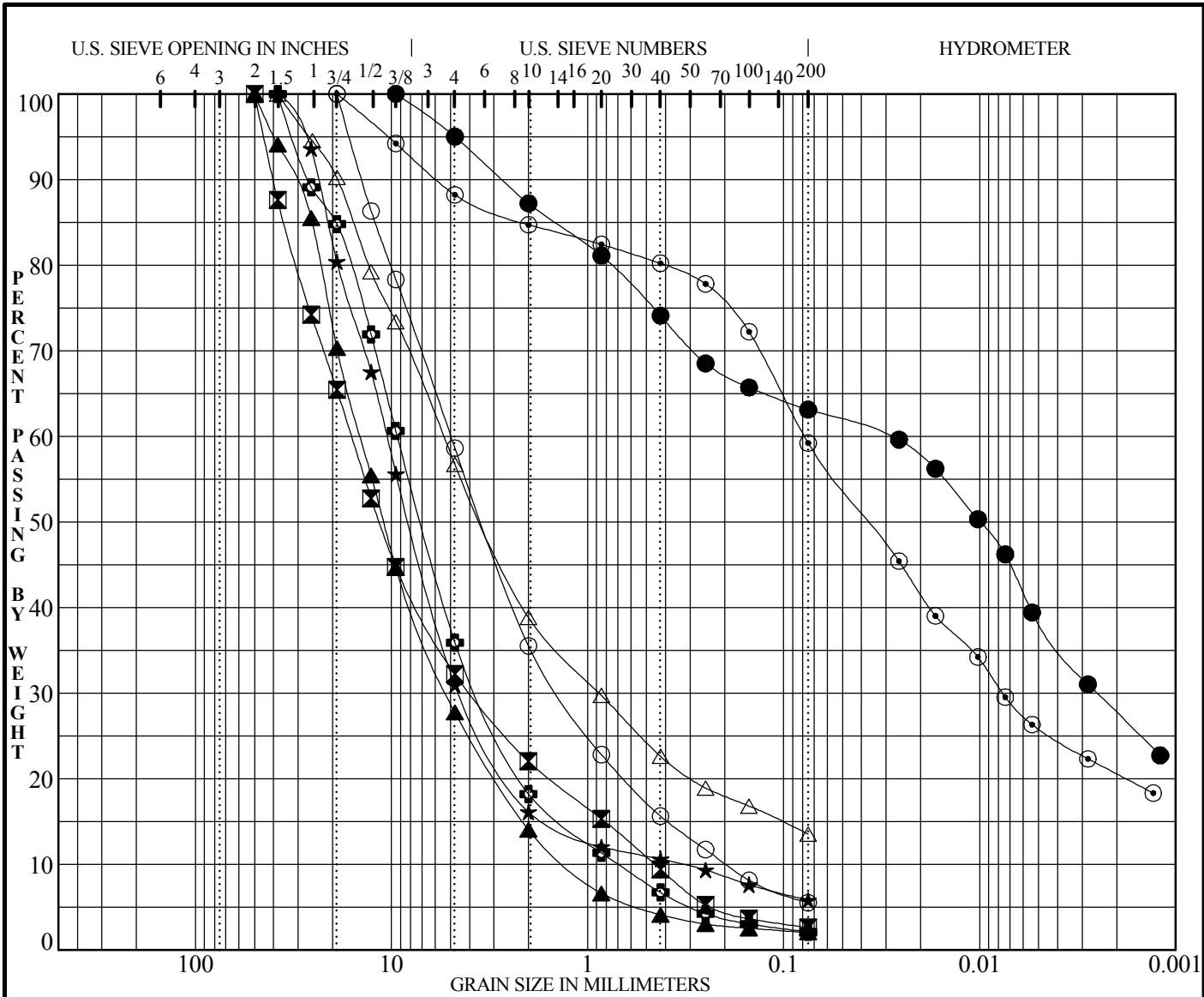

Cobbles	Gravel		Sand			Silt and Clay
	Coarse	Fine	Coarse	Medium	Fine	

Key Symbol	Boring No.	Depth (Feet)	% Passing No. 200 Sieve	% Passing No. 4 Sieve	Sample Description	USCS
●	BH-107	79.5	63	95	Sandy Lean CLAY (CL)	CL
⊠	BH-107	83.7	3	32	Well-graded GRAVEL with sand (GW)	GW
▲	BH-107	90.0	2	28	Well-graded GRAVEL with sand (GW)	GW
★	BH-107	94.5	6	31	Poorly-graded GRAVEL with clay and sand (GP-GC)	GP-GC
⊙	BH-107	95.9	59	88	Sandy Lean CLAY (CL)	CL
⊕	BH-107	100.0	2	36	Well-graded GRAVEL with sand (GW)	GW
○	BH-107	105.5	6	59	Well-graded SAND with clay and gravel (SW-SC)	SW-SC
△	BH-107	109.7	14	57	Clayey GRAVEL with sand (GC)	GC

GRAIN SIZE - SVRT POST-65% PHASE SVRT PHASE2.GPJ SVRT-BART.GDT 9/11/09

	PREPD BY: A. Jain	GRADATION TEST DATA	FIGURE
	APPD BY:		
	DATE: 9/11/09	SVRT DOWNTOWN San Jose, California	PROJECT No.
	DWG FILE:		213213JH02

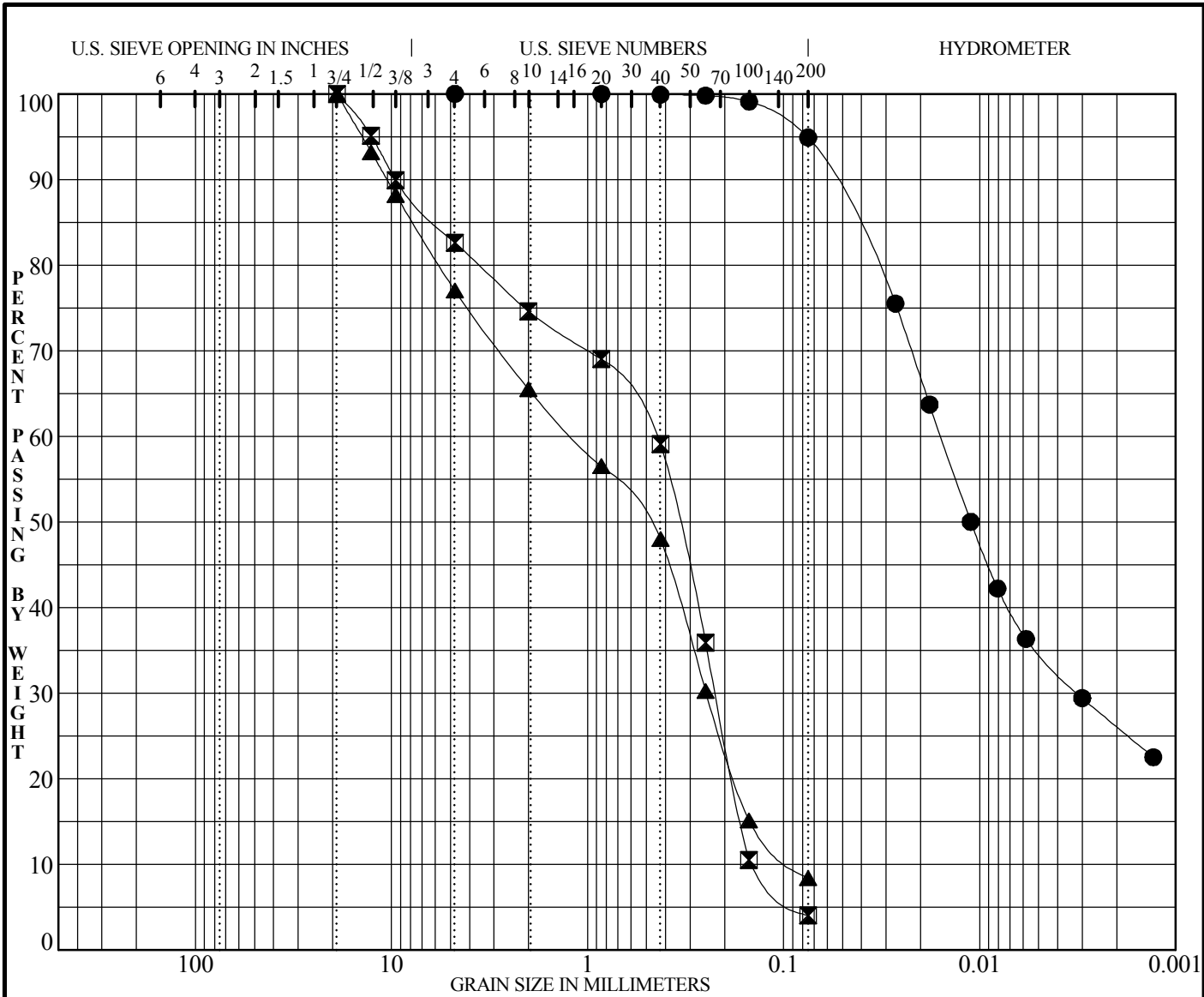

Cobbles	Gravel		Sand			Silt and Clay
	Coarse	Fine	Coarse	Medium	Fine	

Key Symbol	Boring No.	Depth (Feet)	% Passing No. 200 Sieve	% Passing No. 4 Sieve	Sample Description	USCS
●	BH-107	114.6	95	100	Lean CLAY (CL)	CL
◻	BH-107	119.3	4	83	Poorly-graded SAND with gravel (SP)	SP
▲	BH-107	122.3	8	77	Poorly-graded SAND with silt and gravel (SP-SM)	SP-SM

GRAIN SIZE - SVRT POST-65% PHASE SVRT PHASE2.GPJ SVRT-BART.GDT 9/11/09



PREP'D BY:
A. Jain
APP'D BY:

DATE:
9/11/09
DWG FILE:

GRADATION TEST DATA

SVRT DOWNTOWN
San Jose, California

FIGURE

PROJECT No.
213213JH02

APPENDIX C

Structural Calculations for Equipment and Bridge Patch

SVRT Calculation No. SGENS01 – Rev. A

This page is intentionally left blank.



HMM/Bechtel

SILICON VALLEY RAPID TRANSIT (SVRT) PROJECT CENTRAL AREA GUIDEWAY CALCULATION COVER SHEET

DESIGN FIRM HMM/Bechtel

TYPE OF CALCULATION PRELIMINARY
 FINAL
 INDEPENDENT
CHECK
CALCULATION

FACILITY/SUBJECT Coyote Creek Bridge Exploratory Boring DISCIPLINE Structural

COMPONENT Bridge Superstructure CALC. NO. SGENS01

INITIATOR Aaron J. Miller AM 8/12/2009
(PRINT NAME) (INITIAL) (DATE COMPLETED)

CHECKER Ching L. Wu CLW 8-13-2009
(PRINT NAME) (INITIAL) (DATE COMPLETED)

CHECKING METHOD STEP-BY-STEP ALTERNATIVE

APPROVED Michael Lehner ML 8/13/2009
(PRINT NAME) (INITIAL) (DATE COMPLETED)

RECORD OF REVISIONS

REV. NO.	DESCRIPTION (REASON)	BY NAME INITIAL	CHECKED NAME INITIAL	APPROVED NAME INITIAL	DATE
△					

NUMBER OF CALCULATION SHEETS

NEW	SUPERSEDED	TOTAL EFFECTIVE	TOTAL SUPERSEDED	TOTAL SHEETS



SILICON VALLEY RAPID TRANSIT PROJECT

P0503-D300 CENTRAL AREA GUIDEWAY

HMM/Bechtel

Subject: Coyote Creek Bridge Geotechnical Exploration		Prepared by: Aaron J. Miller, P.E.	Date: 12-Aug-2009	Discipline: Structural
Component: Bridge Equipment Loading Analysis		Checked by: Ching-Liu Wu, S.E.	Date: 13-Aug-2009	
Calculation No: SGENS01	Rev. No. A			Sheet No.: 1 of 33

GEOTECHNICAL EXPLORATION PROGRAM COYOTE CREEK BRIDGE LOADING ANALYSIS



SILICON VALLEY RAPID TRANSIT PROJECT

P0503-D300 CENTRAL AREA GUIDEWAY

HMM/Bechtel

Subject: Coyote Creek Bridge Geotechnical Exploration		Prepared by: Aaron J. Miller, P.E.	Date: 12-Aug-2009	Discipline: Structural
Component: Bridge Equipment Loading Analysis		Checked by: Ching-Liu Wu, S.E.	Date: 13-Aug-2009	
Calculation No: SGENS01	Rev. No. A			Sheet No.: 2 of 33

TABLE OF CONTENTS

Calculation Scope	3
Background Information	3
Calculation Criteria, Codes and Standards	4
Calculation Diagrams and Schematics	5
Computations and Results	13
>Flexural Capacity Check	19
>Punching Shear Capacity Check	21
>Restoration Deck Patch Detail Capacity Check	29
Conclusions and Recommendations	32
Attachments	33



SILICON VALLEY RAPID TRANSIT PROJECT

P0503-D300 CENTRAL AREA GUIDEWAY

HMM/Bechtel

Subject: Coyote Creek Bridge Geotechnical Exploration		Prepared by: Aaron J. Miller, P.E.	Date: 12-Aug-2009	Discipline: Structural
Component: Bridge Equipment Loading Analysis		Checked by: Ching-Liu Wu, S.E.	Date: 13-Aug-2009	
Calculation No: SGENS01	Rev. No. A			Sheet No.: 3 of 33

Calculation Scope

The loading conditions modeled for the analysis of the Coyote Creek Bridge Geotechnical Exploration Equipment loading follow the information provided by Boart Longyear (see Appendix A) and the Caltrans Bridge Design Specifications February 2004 Section 3 - Loads. After inspection of the existing bridge, several assumptions were made to determine the specific load conditions to be applied according to these specifications. The assumptions were made due to the limited availability of detailed or complete bridge design drawings. The purpose of the calculations is the determination of dead loads plus concentrated live loads and their demand on the bridge structure. Caltrans defines dead load as, "the weight of the entire structure, including the roadway, sidewalks, car tracks, pipes, conduits, cables, and other public utility services". Live load is defined as "the weight of the applied moving load of vehicles, cars, and pedestrians". Different load configurations prescribed in the specifications were considered to determine the most critical case under the temporary exploration equipment loading. The following calculations illustrate and describe this method.

Background Information

The current plans on file with the City of San Jose Department of Public Works for the existing structure are scanned copies of the May 22, 1918 Girder Type Drawings. These drawings confirm the design of the four span cast-in-place reinforced concrete structure in place over the creek today. The bridge was originally designed to carry rail transit down the middle of the bridge supported by two large deep girders. It is assumed that this middle track area was filled with asphalt to accommodate the four lanes of traffic currently in use on the structure.

The westbound lane on north side of the bridge will be closed for the geotechnical exploration program with the deck penetration for the boring to occur between piers 2 and pier 3. Three heavy axle vehicles with outrigger supports will be placed in this lane to conduct the exploration work. Exploration equipment dimensions and loading were provided by Boart Longyear. The following calculation checks the loading demands against the existing bridge capacity with equipment lay-down areas designed accordingly.



SILICON VALLEY RAPID TRANSIT PROJECT

P0503-D300 CENTRAL AREA GUIDEWAY

HMM/Bechtel

Subject: Coyote Creek Bridge Geotechnical Exploration		Prepared by: Aaron J. Miller, P.E.	Date: 12-Aug-2009	Discipline: Structural
Component: Bridge Equipment Loading Analysis		Checked by: Ching-Liu Wu, S.E.	Date: 13-Aug-2009	
Calculation No: SGENS01	Rev. No. A			Sheet No.: 4 of 33

Calculation Criteria

The bridge load capacity criteria outlined by the Caltrans Specifications, requires the bridge to support both dead loads, w_D , and live loads, w_L . The bridge is modeled for the analysis of these load conditions over the length of the bridge with the addition of the exploration equipment. Spans 1&4 are considered to be simply supported, and no significant stress in the structural components for these spans will result from the temporary loading. The two center spans 2 and 3 are continuous over the center pier, and are the focus of all calculations hereafter. The following structural elements are evaluated for exploration equipment loads.

Coyote Creek Bridge at Santa Clara Street

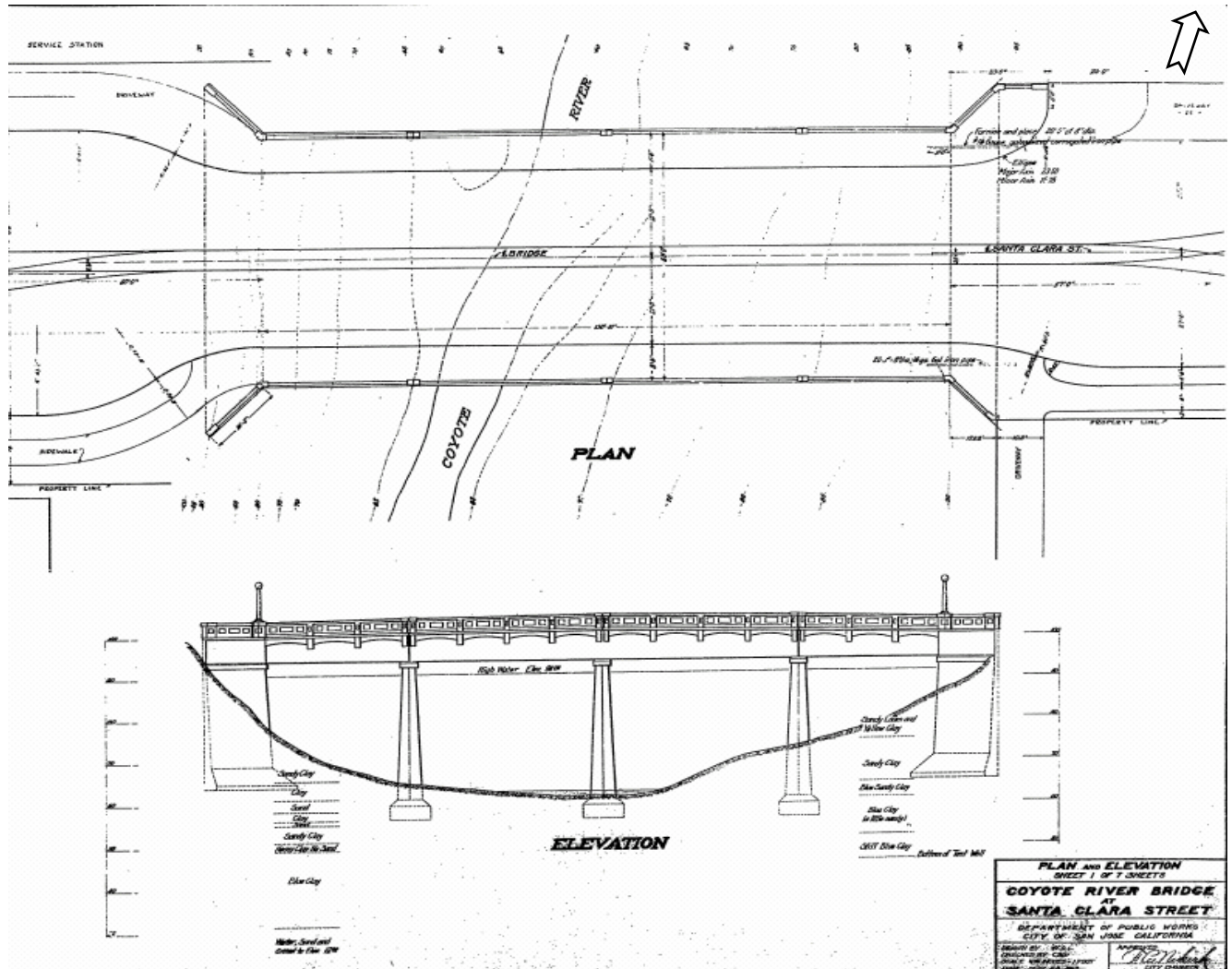



SILICON VALLEY RAPID TRANSIT PROJECT

P0503-D300 CENTRAL AREA GUIDEWAY

HMM/Bechtel

Subject: Coyote Creek Bridge Geotechnical Exploration		Prepared by: Aaron J. Miller, P.E.	Date: 12-Aug-2009	Discipline: Structural
Component: Bridge Equipment Loading Analysis		Checked by: Ching-Liu Wu, S.E.	Date: 13-Aug-2009	
Calculation No: SGENS01	Rev. No. A			Sheet No.: 5 of 33

Bridge Superstructure Components

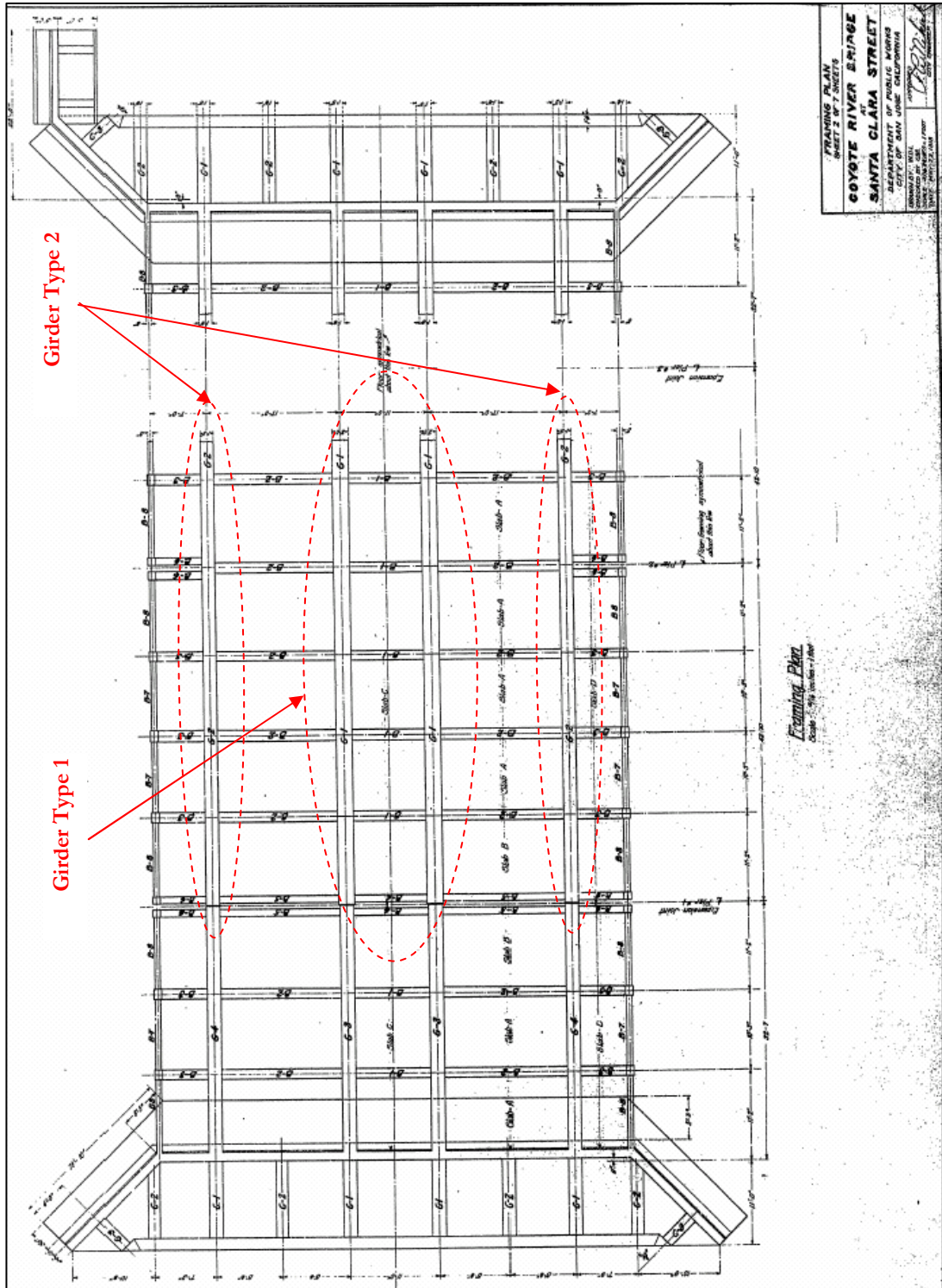



SILICON VALLEY RAPID TRANSIT PROJECT

P0503-D300 CENTRAL AREA GUIDEWAY

HMM/Bechtel

Subject: Coyote Creek Bridge Geotechnical Exploration		Prepared by: Aaron J. Miller, P.E.		Date: 12-Aug-2009	Discipline: Structural
Component: Bridge Equipment Loading Analysis		Checked by: Ching-Liu Wu, S.E.		Date: 13-Aug-2009	
Calculation No: SGENS01	Rev. No. A			Sheet No.: 6 of 33	

Coyote Creek Bridge Deck Cross Sections

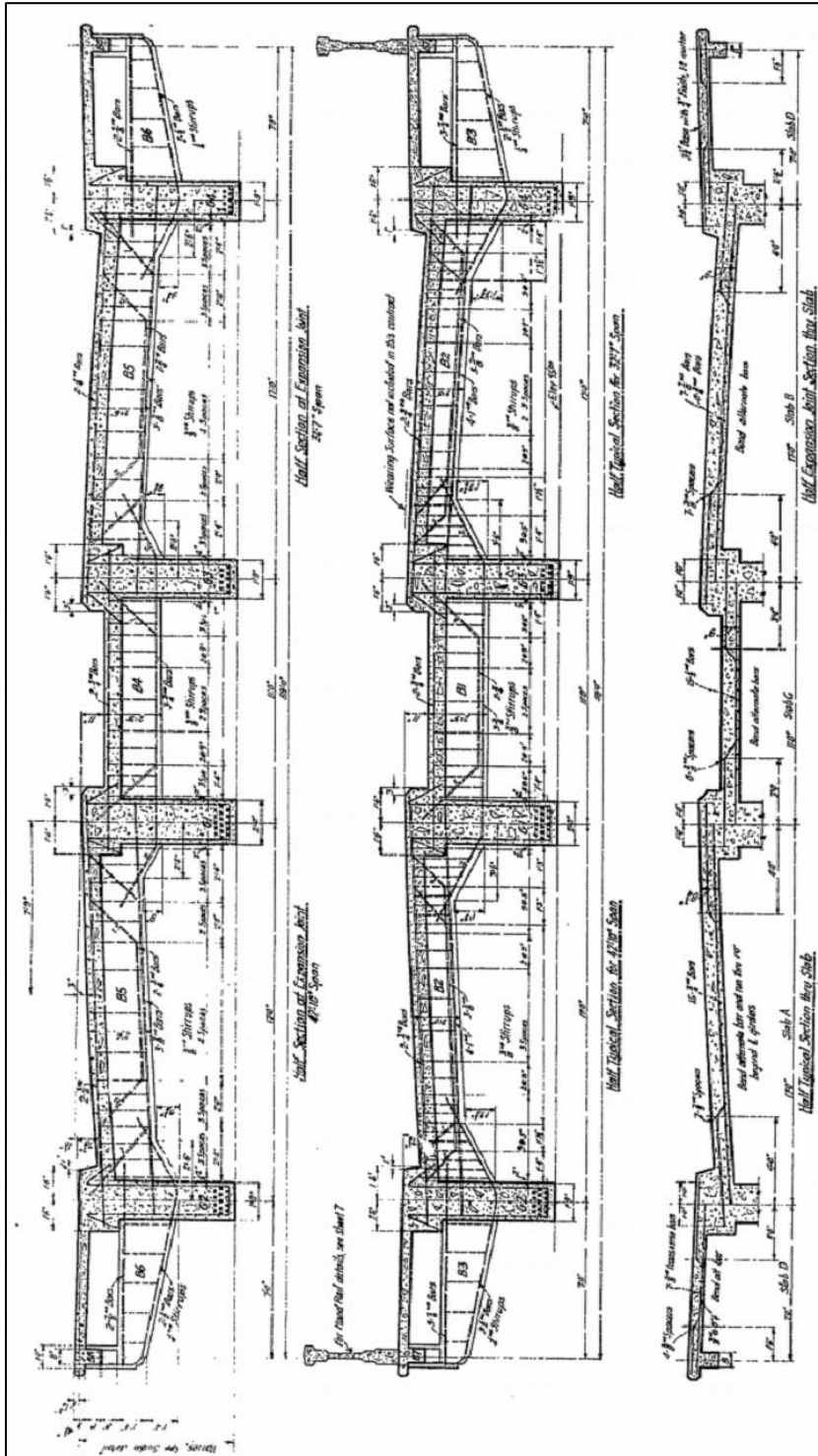



SILICON VALLEY RAPID TRANSIT PROJECT

P0503-D300 CENTRAL AREA GUIDEWAY

HMM/Bechtel

Subject: Coyote Creek Bridge Geotechnical Exploration		Prepared by: Aaron J. Miller, P.E.	Date: 12-Aug-2009	Discipline: Structural
Component: Bridge Equipment Loading Analysis		Checked by: Ching-Liu Wu, S.E.	Date: 13-Aug-2009	
Calculation No: SGENS01	Rev. No. A			Sheet No.: 7 of 33

Bridge Caltrans Loading Conditions

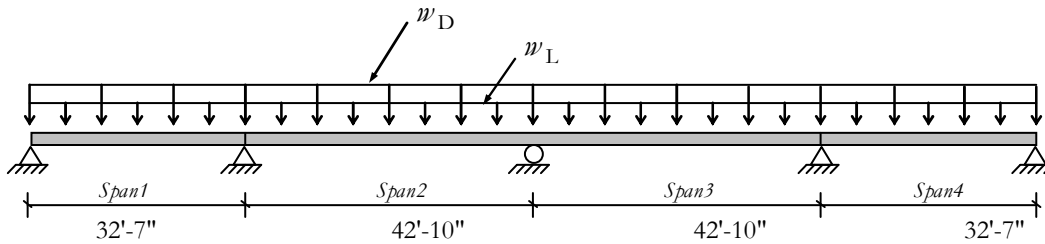

Deck Slabs

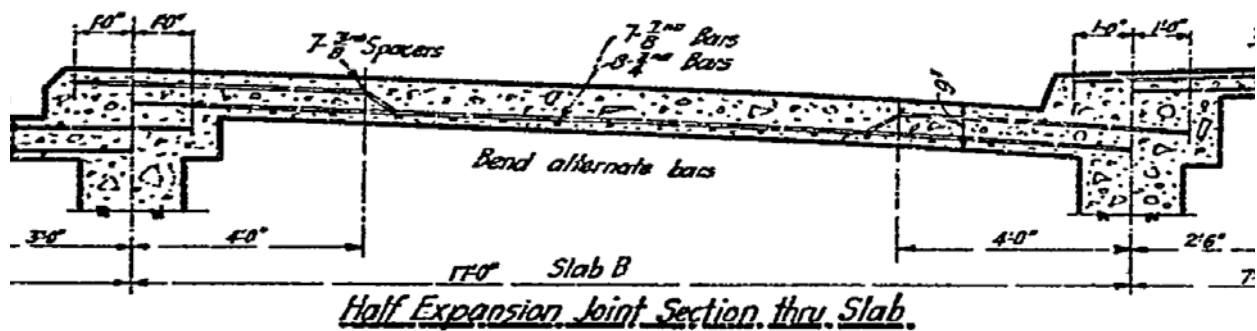
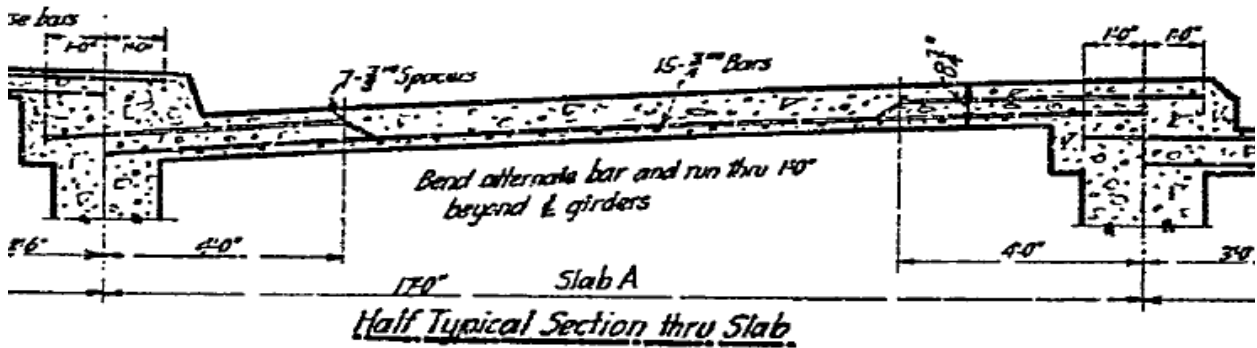



SILICON VALLEY RAPID TRANSIT PROJECT

P0503-D300 CENTRAL AREA GUIDEWAY

HMM/Bechtel

Subject: Coyote Creek Bridge Geotechnical Exploration		Prepared by: Aaron J. Miller, P.E.	Date: 12-Aug-2009	Discipline: Structural
Component: Bridge Equipment Loading Analysis		Checked by: Ching-Liu Wu, S.E.	Date: 13-Aug-2009	
Calculation No: SGENS01	Rev. No. A			Sheet No.: 8 of 33

Longitudinal Girders

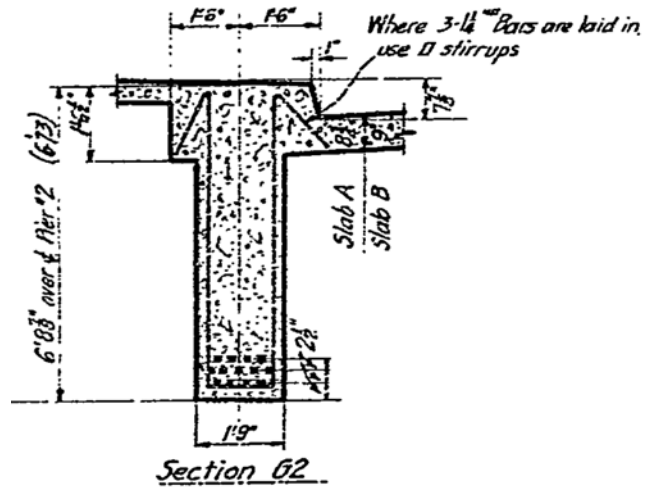
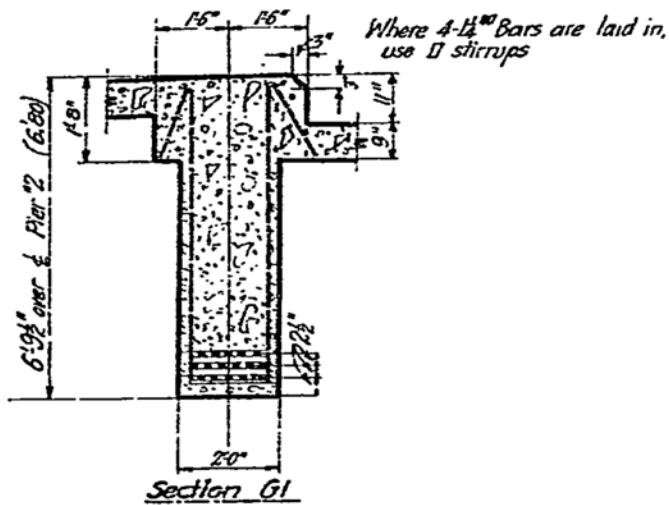

Deck Beams

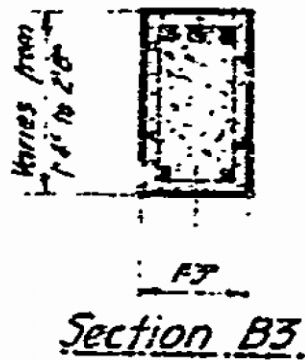
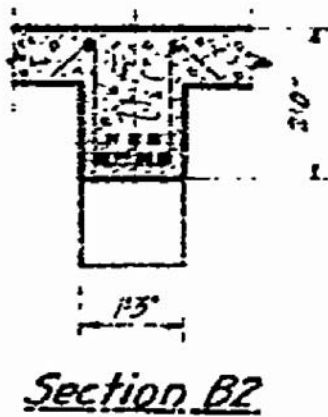



SILICON VALLEY RAPID TRANSIT PROJECT

P0503-D300 CENTRAL AREA GUIDEWAY

HMM/Bechtel

Subject: Coyote Creek Bridge Geotechnical Exploration		Prepared by: Aaron J. Miller, P.E.	Date: 12-Aug-2009	Discipline: Structural
Component: Bridge Equipment Loading Analysis		Checked by: Ching-Liu Wu, S.E.	Date: 13-Aug-2009	
Calculation No: SGENS01	Rev. No. A			Sheet No.: 9 of 33

Dead Load Calculations

Cast-in-Place Slab:

		d	b	
d_{slab} = slab thickness		G1	0.75	14.00 ft
b_E = effective slab width over girders		G2	0.58	14.00 ft
$DL_c = 0.15 \text{ k/ft}^3$ = concrete dead load Caltrans '03, 3-3		G3	0.58	14.00 ft
A_{slab} = area slab per linear foot of deck, (ft ²)		G4	0.58	14.00 ft

	G1	G2	G3	G4
A_{slab}	10.50	8.17	8.17	8.17

Asphalt Pavement:

d_{asph} = asphalt thickness		d_{slab}	0.50	ft
b_E = effective asphalt width over girders		b_{EG1}	14	ft
$DL_{asph} = 0.15 \text{ k/ft}^3$ = asphalt dead load Caltrans '03, 3-3		b_{EG2}	8.5	ft
A_{asph} = area slab per linear foot of deck, (ft ²)		b_{EG3}	14	ft
		b_{EG4}	8.5	ft

	G1	G2	G3	G4
A_{asph}	7.00	4.25	7.00	4.25

Deck Beams:

d_{db} = average deck beam thickness		d_{db}	1.50	ft
b_E = effective beam width interpolated over girders*		b_{EG1}	0.118	ft
$DL_c = 0.15 \text{ k/ft}^3$ = concrete dead load Caltrans '03, 3-3		b_{EG2}	0.118	ft
A_{db} = area deck per linear foot of deck, (ft ²)		b_{EG3}	0.118	ft
		b_{EG4}	0.118	ft

	G1	G2	G3	G4
A_{db}	0.18	0.47	0.18	0.47

* Effective beam width is interpolated by taking the number of deck beams in spans 2 & 3 and multiplying by the average width of the 6 different deck beams. This is then divided into the length of the two spans to result in an effective width per linear foot of bridge deck. Girders 2 & 4 also include railing area.



SILICON VALLEY RAPID TRANSIT PROJECT

P0503-D300 CENTRAL AREA GUIDEWAY

HMM/Bechtel

Subject: Coyote Creek Bridge Geotechnical Exploration		Prepared by: Aaron J. Miller, P.E.		Date: 12-Aug-2009		Discipline: Structural	
Component: Bridge Equipment Loading Analysis		Checked by: Ching-Liu Wu, S.E.		Date: 13-Aug-2009			
Calculation No: SGENS01			Rev. No. A			Sheet No.: 10 of 33	

Dead Load Calculations

Girders:

d_g = average girder thickness

b_E = effective girder width

$DL_c = 0.15 \text{ k/ft}^3$ = concrete dead load Caltrans '03, 3-3

	G1	G2	G3	G4
A_g	10.00	8.75	8.75	8.75

	d	b	
G1	5.00	2.00	ft
G2	5.00	1.75	ft
G3	5.00	1.75	ft
G4	5.00	1.75	ft

Total Dead Load, w_D :

$$w_D = \Sigma[(\text{contributing dead load areas}) \times (\text{Caltrans' weights})], (\text{k/LF})$$

	G1	G2	G3	G4
w_D	4.15	3.25	3.61	3.25

DL_{slab}	0.15	k/ft ³
DL_{asph}	0.15	k/ft ³
DL_{db}	0.15	k/ft ³
DL_g	0.15	k/ft ³

Load Factors: Caltrans 3.22.1

$$\text{Group (N)} = \gamma[\beta_D D + \beta_L(L + I) + \beta_C CF + \beta_E E + \beta_B B + \beta_S SF + \beta_W W + \beta_{PS} PS + \beta_{WL} WL + \beta_{LF} LF + \beta_R(R + S + T) + \beta_{EQ} EQ + \beta_{ICE} ICE + \beta_{CT} CT] \quad (3-10)$$

where

- N = group number;
- γ = load factor, see Table 3.22.1A and B;
- β = coefficient, see Table 3.22.1A and B;
- D = dead load;
- L = live load;
- I = live load impact;
- E = earth pressure;
- B = buoyancy;

TABLE 3.22.1A Factors for Load Factor Design

Group	Gamma Factor	D	Beta Factors															
			(L+DH)	(L+DF)	CF	E	B	SF	W	WL	LF	PS	R+S+T	EQ	ICE	CT		
I _L	1.30	βD	1.67	0	1	βE	1	1	0	0	0	0.77	0	0	0	0		
I _{TC}	1.30	βD	0	1	1	βE	1	1	0	0	0	0.77	0	0	0	0		
I _{FW}	1.30	βD	1	1.15	1	βE	1	1	0	0	0	0.77	0	0	0	0		
I _{FD}	1.30	βD	1	1.25	1	βE	1	1	0	0	0	0.77	0	0	0	0		
II	1.30	βD	0	0	0	βE	1	1	1	0	0	0.77	0	0	0	0		
III	1.30	βD	1	0	1	βE	1	1	0.3	1	1	0.77	0	0	0	0		
IV	1.30	βD	1	0	1	βE	1	1	0	0	0	0.77	1	0	0	0		
V	1.25	βD	0	0	0	βE	1	1	1	0	0	0.80	1	0	0	0		
VI	1.25	βD	1	0	1	βE	1	1	0.3	1	1	0.80	1	0	0	0		
VII	1.00	1	0	0	0	βE	1	1	0	0	0	1.00	0	1	0	0		
VIII	1.30	βD	1	0	1	βE	1	1	0	0	0	0.77	0	0	1	0		
IX	1.20	βD	0	0	0	βE	1	1	1	0	0	0.83	0	0	1	0		
X*	1.30	βD	1.67	0	0	βE	0	0	0	0	0	0.67	0	0	0	0		
XI	1.0	1.0	0.5	0	0	βE	0	0	0	0	0	1.0	0	0	0	1		

Applying the load combinations, the load equation becomes:

$$\gamma[\beta_D D + \beta_L(L + I)]$$

Where the coefficients are taken from Caltrans Table 3.22.1A as follows:

For the most critical load combination the coefficients are: \rightarrow

$\gamma = 1.3$
 $\beta_D = 1.00$
 $\beta_L = 1.67$
 $I = 0.30$

The resulting load factors are:

Factored Dead Load, w_D :

	G1	G2	G3	G4
w_D	5.40	4.22	4.70	4.22

Dead Load Factor = 1.30

Live Load Factor = 2.17



SILICON VALLEY RAPID TRANSIT PROJECT

P0503-D300 CENTRAL AREA GUIDEWAY

HMM/Bechtel

Subject: Coyote Creek Bridge Geotechnical Exploration		Prepared by: Aaron J. Miller, P.E.		Date: 12-Aug-2009	Discipline: Structural
Component: Bridge Equipment Loading Analysis		Checked by: Ching-Liu Wu, S.E.		Date: 13-Aug-2009	
Calculation No: SGENS01	Rev. No. A				Sheet No.: 11 of 33

Live Load Calculations

According to the Caltrans Bridge Design Specifications 2003 Article 3.7.4 Minimum Loading, "Bridges shall be designed for HS20-44 loading or an Alternate Military Loading of two axles four feet apart with each axle weighing 24,000 pounds, which ever produces the greatest stress."

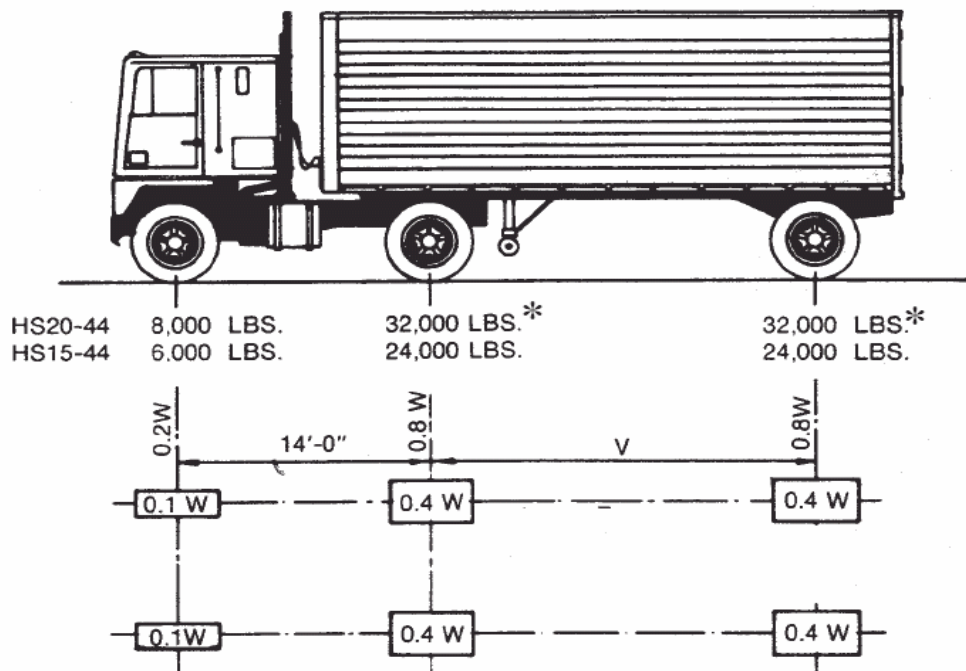

	HS20-44 8,000 LBS.	32,000 LBS.*	
	HS15-44 6,000 LBS.	24,000 LBS.	32,000 LBS.*
		24,000 LBS.	24,000 LBS.

W = COMBINED WEIGHT ON THE FIRST TWO AXLES WHICH IS THE SAME AS FOR THE CORRESPONDING H TRUCK.
V = VARIABLE SPACING — 14 FEET TO 30 FEET INCLUSIVE. SPACING TO BE USED IS THAT WHICH PRODUCES MAXIMUM STRESSES.

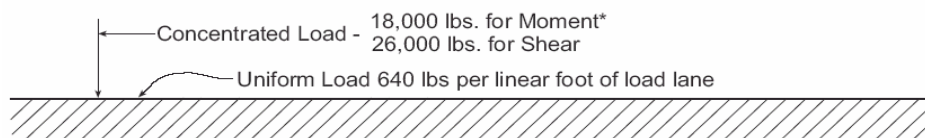

H20 - 44 LOADING
HS20 - 44 LOADING

* For the loading of continuous spans involving lane loading refer to Article 3.11.3 which provides for an additional concentrated load.



SILICON VALLEY RAPID TRANSIT PROJECT

P0503-D300 CENTRAL AREA GUIDEWAY

HMM/Bechtel

Subject: Coyote Creek Bridge Geotechnical Exploration		Prepared by: Aaron J. Miller, P.E.	Date: 12-Aug-2009	Discipline: Structural
Component: Bridge Equipment Loading Analysis		Checked by: Ching-Liu Wu, S.E.	Date: 13-Aug-2009	
Calculation No: SGENS01	Rev. No. A			Sheet No.: 12 of 33

Live Load Calculations

When considering load effects on moments, Caltrans specifies Article 3.11.3 for loading of continuous spans.

"Article 3.11.3 Lane Loads on Continuous Spans

For the determination of maximum negative moment in the design of continuous spans, the load shown in the Figure 3.7.6B (shown above) shall be modified by the addition of a second, equal weight concentrated load placed in one other span in the series in such position to produce the maximum effect. For maximum positive moment, only one concentrated load shall be used per lane, combined with as many spans loaded uniformly as are required to produce maximum moment."

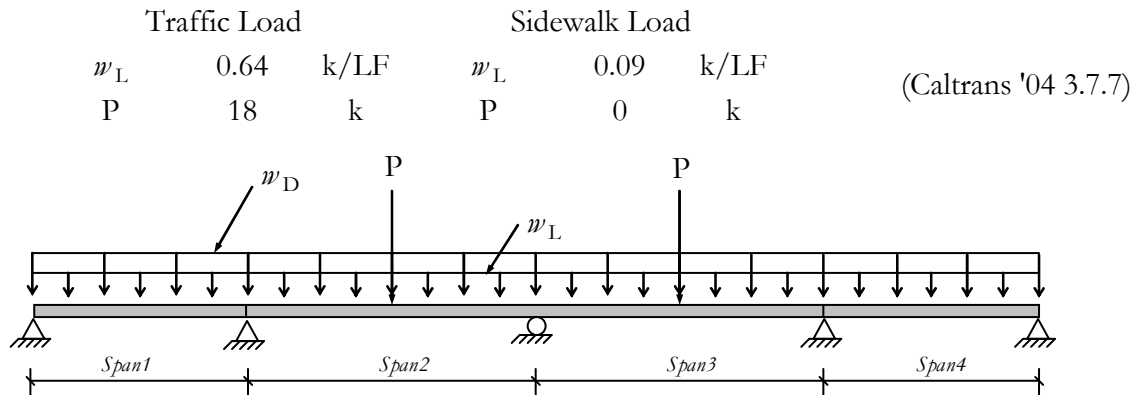

Factored Live Load, w_L :

Traffic Load		Sidewalk Load	
w_L	2.04 k/LF	w_L	0.18 k/LF
P	39.078 k	P	0 k

Un-Factored Loads, w & P:					Factored Loads, w & P:					
	G1	G2	G3	G4		G1	G2	G3	G4	
w	4.79	2.97	4.25	2.97	w	7.44	5.52	6.74	5.52	k/LF
P	18.00	18.00	18.00	18.00	P	39.08	39.08	39.08	39.08	k



SILICON VALLEY RAPID TRANSIT PROJECT

P0503-D300 CENTRAL AREA GUIDEWAY

HMM/Bechtel

Subject: Coyote Creek Bridge Geotechnical Exploration		Prepared by: Aaron J. Miller, P.E.	Date: 12-Aug-2009	Discipline: Structural
Component: Bridge Equipment Loading Analysis		Checked by: Ching-Liu Wu, S.E.	Date: 13-Aug-2009	
Calculation No: SGENS01	Rev. No. A			Sheet No.: 13 of 33

Computations and Results

Girder Design Capacity

Girders 1 and 2 were modeled as a T-girder in accordance with Caltrans Bridge Design Specifications (CBDS) Section 8.10.1.1.

(CBDS) Section 8.10.1.1 - The total width of slab effective as a T-girder flange shall not exceed one-fourth of the span length of the girder. The effective flange width overhanging on each side of the web shall not exceed six times the thickness of the slab or one-half the clear distance to the next web.

$$L_{\text{span}} = 42.83 \text{ ft}$$

$$b_E = 10.7075 \text{ ft}$$

Concrete clear cover of 2" was assumed for all reinforcing steel. The depth of reinforcement was measured to include this clear cover assumption.

An equivalent flange section was modeled to approximate the compression flange for the staggered deck slab section over girders 1 and 2. This model section is used for the capacity analysis, and is shown below.

Girder 1 (slab B)

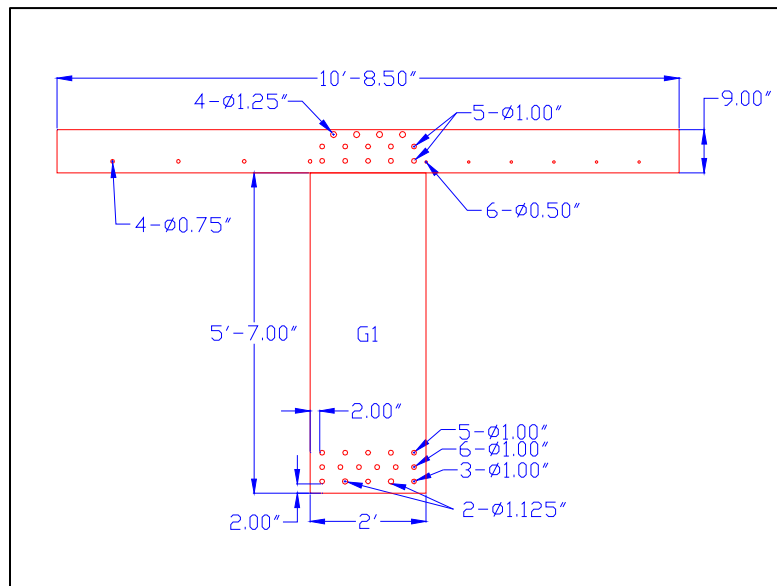

NOTE:
Slab A is 8.75"
thick



SILICON VALLEY RAPID TRANSIT PROJECT

P0503-D300 CENTRAL AREA GUIDEWAY

HMM/Bechtel

Subject: Coyote Creek Bridge Geotechnical Exploration		Prepared by: Aaron J. Miller, P.E.	Date: 12-Aug-2009	Structural
Component: Bridge Equipment Loading Analysis		Checked by: Ching-Liu Wu, S.E.	Date: 13-Aug-2009	
Calculation No: SGENS01	Rev. No. A			Sheet No.: 14 of 33

Design (+) Moment Strength (G1)

$$\phi M_n = \phi \left[A_s \times f_y \left(d - \frac{a}{2} \right) \right] \quad \left(\begin{array}{l} \text{design moment strength, } \phi M_n \\ \text{Caltrans '03 eq. 8-16} \end{array} \right)$$

$$a = \frac{A_s \times f_y}{0.85(f'_c)(b_E)} \quad a = h_{cr} = \text{equivalent rectangular stress block}$$

$$I_{cr} = \left(\frac{b_E \times h_{cr}^3}{3} \right) + n A_s (d^2)$$

I_{cr} = moment of inertia of cracked transformed section

b_E = width of effective section

h_{cr} = depth of cracked section

$$n = \left(\frac{E_s}{E_c} \right), \text{ modulus of elasticity ratio}$$

A_s = area of tension reinforcement (combined rebar area in lower section of girder)

d = effective depth, distance from the compression face to centroid of tension steel

Girder 1			Reinforcement		
E_s	29000	ksi	(Assume conservatively reinforcing steel is round)		
E_c	2900	ksi			
f_y	33	ksi	$A_{1-1/8" \text{ bar}}$	0.99	in^2
f'_c	2.5	ksi	$A_{1" \text{ bar}}$	0.79	in^2
b_E	128.50	in	$A_{1/2" \text{ bar}}$	0.20	in^2
h	76.0	in	$\#A_{1-1/8" \text{ bar}}$	2	
h_{cr}	1.57	in	$\#A_{1" \text{ bar}}$	14	
n	10		$\#A_{1/2" \text{ bar}}$	0	
A_s	12.98	in^2			
d	70.5	in			
I_{cr}	645484	in^4			
EI_{cr}	12999321	k-ft^2			
ϕ	0.9				

M_n	2489	k-ft
ϕM_n	2240	k-ft



SILICON VALLEY RAPID TRANSIT PROJECT

P0503-D300 CENTRAL AREA GUIDEWAY

HMM/Bechtel

Subject: Coyote Creek Bridge Geotechnical Exploration		Prepared by: Aaron J. Miller, P.E.	Date: 12-Aug-2009	Discipline: Structural
Component: Bridge Equipment Loading Analysis		Checked by: Ching-Liu Wu, S.E.	Date: 13-Aug-2009	
Calculation No: SGENS01	Rev. No. A			Sheet No.: 15 of 33

Design (-) Moment Strength (G1)

The same flexural moment equations apply as above.

Girder 1			Reinforcement		
E_s	29000	ksi	(Assume conservatively reinforcing steel is round)		
E_c	2900	ksi			
f_y	33	ksi	$A_{1-1/4" \text{ bar}}$	1.23	in^2
f'_c	2.5	ksi	$A_{1" \text{ bar}}$	0.79	in^2
b_E	24.00	in	$A_{3/4" \text{ bar}}$	0.44	in^2
h	76.0	in	$A_{1/2" \text{ bar}}$	0.20	in^2
h_{cr}	10.16	in	$\#A_{1-1/4" \text{ bar}}$	4	
n	10		$\#A_{1" \text{ bar}}$	10	
A_s	15.71	in^2	$\#A_{3/4" \text{ bar}}$	4	
d	71.5	in	$\#A_{1/2" \text{ bar}}$	6	
I_{cr}	811430	in^4			
EI_{cr}	16341306	k-ft^2			
ϕ	0.9				

M_n	2869	k-ft
ϕM_n	2582	k-ft



SILICON VALLEY RAPID TRANSIT PROJECT

P0503-D300 CENTRAL AREA GUIDEWAY

HMM/Bechtel

Subject: Coyote Creek Bridge Geotechnical Exploration		Prepared by: Aaron J. Miller, P.E.		Date: 12-Aug-2009		Discipline:		
						Structural		
Component: Bridge Equipment Loading Analysis		Checked by: Ching-Liu Wu, S.E.		Date: 13-Aug-2009				
Calculation No: SGENS01			Rev. No. A				Sheet No.: 16 of 33	

Design Shear Strength (G1)

$$\phi V_n = \phi(V_c + V_s) \quad \left(\begin{array}{l} \text{nominal shear strength, } V_n \\ \text{Caltrans '03, eq. 8-47} \end{array} \right)$$

$$V_c = 2\sqrt{f'_c}(b_w d) \quad \left(\begin{array}{l} \text{nominal shear strength provided by concrete, } V_c \\ \text{Caltrans '03, eq. 8-49} \end{array} \right)$$

$$V_s = \frac{A_v f_y d}{s} \quad \left(\begin{array}{l} \text{nominal shear strength provided} \\ \text{by shear reinforcement, } V_s \\ \text{Caltrans '03, eq. 8-53} \end{array} \right)$$

Girder 1

f_y	33000	psi
f'_c	2500	psi
f_s	16000	psi
α	45	in
s	6.6	in
b_w	24	in
A_v	2.45	in ²
d	72	in
ϕ	0.85	
$v-v_c$	113	kips
V_c	172	kips
V_s	877	kips

Reinforcement

(Assume conservatively reinforcing steel is round)

$A_{1'' \text{ bar}}$	0.79	in ²
$A_{1-1/8'' \text{ bar}}$	0.99	in ²
$A_{1-1/4'' \text{ bar}}$	1.23	in ²
$\#A_{1'' \text{ bar}}$	14	
$\#A_{1-1/8'' \text{ bar}}$	2	
$\#A_{1-1/4'' \text{ bar}}$	0	

V_n	1049	kips	
ϕV_n	892	kips	



SILICON VALLEY RAPID TRANSIT PROJECT

P0503-D300 CENTRAL AREA GUIDEWAY

HMM/Bechtel

Subject: Coyote Creek Bridge Geotechnical Exploration		Prepared by: Aaron J. Miller, P.E.	Date: 12-Aug-2009	Discipline: Structural
Component: Bridge Equipment Loading Analysis		Checked by: Ching-Liu Wu, S.E.	Date: 13-Aug-2009	
Calculation No: SGENS01	Rev. No. A			Sheet No.: 17 of 33

Girder 2 (slab B)

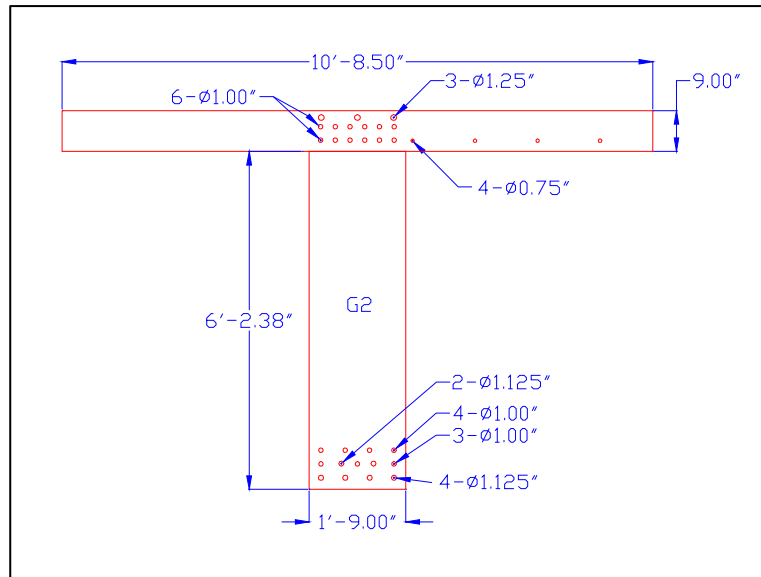

NOTE:
Slab A is 8.75\"
thick

Design (+) Moment Strength (G2)

The same flexural moment equations apply as above.

Girder 2			Reinforcement		
E_s	29000	ksi	(Assume conservatively reinforcing steel is round)		
E_c	2850	ksi	$A_{1'' \text{ bar}}$	0.79	in^2
f_y	33	ksi	$A_{1-1/8'' \text{ bar}}$	0.99	in^2
f_c	2.5	ksi	$A_{1-1/4'' \text{ bar}}$	1.23	in^2
b_E	128	in	$\#A_{1'' \text{ bar}}$	7	
h	83.4	in	$\#A_{1-1/8'' \text{ bar}}$	6	
h_{cr}	1.39	in	$\#A_{1-1/4'' \text{ bar}}$	0	
n	10				
A_s	11.46	in^2			
d	75	in			
I_{cr}	656157	in^4			
EI_{cr}	12986442	ft^2			
ϕ	0.9				

M_n	2342	k-ft
ϕM_n	2108	k-ft



SILICON VALLEY RAPID TRANSIT PROJECT

P0503-D300 CENTRAL AREA GUIDEWAY

HMM/Bechtel

Subject: Coyote Creek Bridge Geotechnical Exploration		Prepared by: Aaron J. Miller, P.E.		Date: 12-Aug-2009		Discipline: Structural	
Component: Bridge Equipment Loading Analysis		Checked by: Ching-Liu Wu, S.E.		Date: 13-Aug-2009			
Calculation No: SGENS01		Rev. No. A				Sheet No.: 18 of 33	

Design (-) Moment Strength (G2)

The same flexural moment equations apply as above.

Girder 2			Reinforcement		
E_s	29000	ksi	(Assume conservatively reinforcing steel is round)		
E_c	2850	ksi			
f_y	33	ksi	$A_{1-1/4" \text{ bar}}$	1.23	in^2
f'_c	2.5	ksi	$A_{1" \text{ bar}}$	0.79	in^2
b_E	21	in	$A_{3/4" \text{ bar}}$	0.44	in^2
h	83.4	in	$\#A_{1-1/4" \text{ bar}}$	3	
h_{cr}	11.00	in	$\#A_{1" \text{ bar}}$	12	
n	10		$\#A_{3/4" \text{ bar}}$	4	
A_s	14.87	in^2			
d	76.88	in			
I_{cr}	903839	in^4			
EI_{cr}	17888480	ft^2			
ϕ	0.9				

M_n	2920	k-ft
ϕM_n	2628	k-ft

Design Shear Strength (G2)

The same shear strength equations apply as above.

Girder 2			Reinforcement		
f_y	33000	psi	(Assume conservatively reinforcing steel is round)		
f'_c	2500	psi			
f_s	16000	psi	$A_{1" \text{ bar}}$	0.79	in^2
α	45	in	$A_{1-1/8" \text{ bar}}$	0.99	in^2
s	8.5	in	$A_{1-1/4" \text{ bar}}$	1.23	in^2
b_w	21	in	$\#A_{1" \text{ bar}}$	14	
A_v	2.45	in^2	$\#A_{1-1/8" \text{ bar}}$	2	
d	75	in	$\#A_{1-1/4" \text{ bar}}$	0	
ϕ	0.85				
$v-v_c$	113	kips			
V_c	158	kips			
V_s	715	kips			

V_n	872	kips
ϕV_n	741	kips



SILICON VALLEY RAPID TRANSIT PROJECT

P0503-D300 CENTRAL AREA GUIDEWAY

HMM/Bechtel

Subject: Coyote Creek Bridge Geotechnical Exploration		Prepared by: Aaron J. Miller, P.E.		Date: 12-Aug-2009	Discipline: Structural
Component: Bridge Equipment Loading Analysis		Checked by: Ching-Liu Wu, S.E.		Date: 13-Aug-2009	
Calculation No: SGENS01		Rev. No. A			Sheet No.: 19 of 33

Girder Capacity Results Summary

	Girder 1	Girder 2	
(+) M_n	2489	2342	k-ft
(+) ϕM_n	2240	2108	k-ft
(-) M_n	2869	2920	k-ft
(-) ϕM_n	2582	2628	k-ft
V_n	1049	872	kips
ϕV_n	892	741	kips

Equipment Loading on Girders

The concentrated equipment load demands on the longitudinal girder are checked for the maximum loading scenario. This occurs when both the drill rig and the support rig or working on the bridge. The point loads from the rear outriggers of each truck are positioned in the middle of the span to produce the maximum moment, **P**. The dead load and live of the bridge are also added, w .

$$\begin{aligned}
 \mathbf{P} &= 26 + 14 = 39 \text{ kips} && \text{(from punching calculation below)} \\
 w &= 7.44 \text{ k/LF} \\
 l &= 42.83 \text{ ft}
 \end{aligned}$$

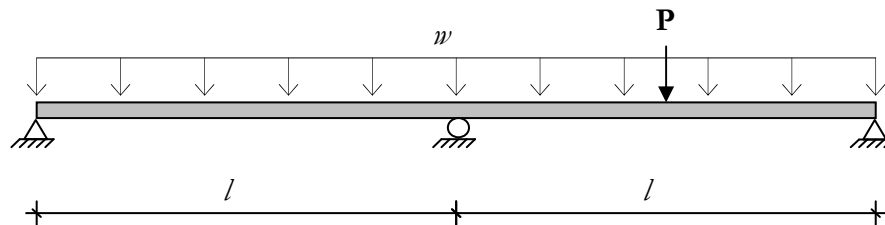

The two middle spans are continues over the middle pier and are modeled in SAP2000 with the distributed and point loads described above. These loading use the LRFD and are conservative. It is assumed the for the critical equipment loading scenario that both girder 1 (G1) and girder 2 (G2) will be subjected to this loading condition. Therefore only the results from modeling G1 are show below.



SILICON VALLEY RAPID TRANSIT PROJECT

P0503-D300 CENTRAL AREA GUIDEWAY

HMM/Bechtel

Subject: Coyote Creek Bridge Geotechnical Exploration		Prepared by: Aaron J. Miller, P.E.	Date: 12-Aug-2009	Discipline: Structural
Component: Bridge Equipment Loading Analysis		Checked by: Ching-Liu Wu, S.E.	Date: 13-Aug-2009	
Calculation No: SGENS01	Rev. No. A			Sheet No.: 20 of 33

Girder Demand Results

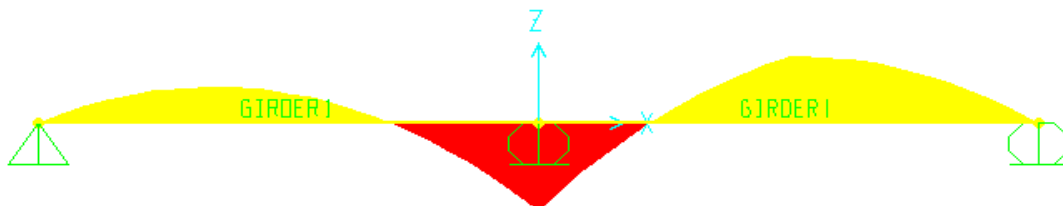
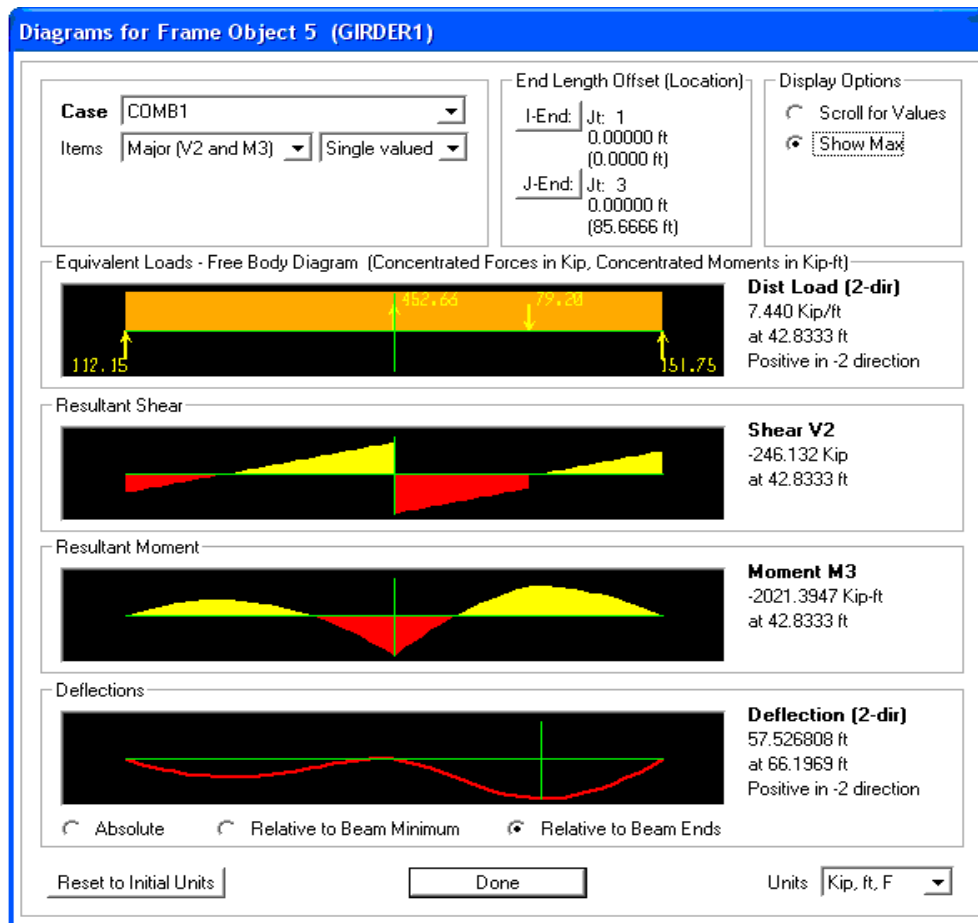

The girder loading analysis results indicate that the maximum flexural demand on the bridge girders is a negative moment of 2022 k-ft at the center span. This demand is 78% of the capacity of G1 and 77% of the capacity of G2. The shear demand is 246 kip which is negligible compared to the shear capacity of these deep beam girders. Therefore, based on the calculation assumptions herein, the flexural and shear capacity of the bridge is sufficient to support the maximum loading scenario from the exploratory boring equipment.



SILICON VALLEY RAPID TRANSIT PROJECT

P0503-D300 CENTRAL AREA GUIDEWAY

HMM/Bechtel

Subject: Coyote Creek Bridge Geotechnical Exploration		Prepared by: Aaron J. Miller, P.E.	Date: 12-Aug-2009	Structural
Component: Bridge Equipment Loading Analysis		Checked by: Ching-Liu Wu, S.E.	Date: 13-Aug-2009	
Calculation No: SGENS01	Rev. No. A			Sheet No.: 21 of 33

Deck Slab Punching Shear Check

Both ACI 318-08 LRFD design and Caltrans Bridge Design Specification (BDS) ASD are reviewed for punching shear from the equipment outriggers on the bridge deck as follows.

$$U = V_u = 1.2D + 1.6L \quad (\text{ACI 318 - 08, Eq. 9 - 2})$$

DL Factor	LL Factor
1.20	1.60

From ACI 318-08 Article 11.11.2.1 – For nonprestressed slabs and footings, V_c shall be the smallest of (a), (b), and (c):

$$\phi V_n = V_c$$

$$V_c = \left(2 + \frac{4}{\beta} \right) \lambda \sqrt{f'_c} b_0 d \quad (\text{ACI 318 - 08, Eq. 11 - 31})$$

$$V_c = \left(\frac{\alpha_s d}{b_0} + 2 \right) \lambda \sqrt{f'_c} b_0 d \quad (\text{ACI 318 - 08, Eq. 11 - 32})$$

$$V_c = 4 \lambda \sqrt{f'_c} b_0 d \quad (\text{ACI 318 - 08, Eq. 11 - 33})$$

Where:

$$\beta = \beta_c = \frac{\text{long side}}{\text{short side}}$$

$$\lambda = 1$$

$$\alpha_s = 40$$

$$d = 8.75 \text{ in}$$

$$f'_c = 2500 \text{ psi}$$

From Caltrans BDS Article 8.15.5.6 Special Provisions for Slabs and Footings, shear capacity of slabs and footings in the vicinity of concentrated loads or reactions shall be:

$$\text{Shear Demand, } v = \frac{V}{b_0 d} \quad (\text{Caltrans BDS09 - 03, Eq. 8 - 12})$$

$$\text{Shear Capacity, } v_c = \left(0.8 + \frac{2}{\beta_c} \right) \sqrt{f'_c} \leq 1.8 \sqrt{f'_c} \quad (\text{Caltrans BDS09 - 03, Eq. 8 - 13})$$



SILICON VALLEY RAPID TRANSIT PROJECT

P0503-D300 CENTRAL AREA GUIDEWAY

HMM/Bechtel

Subject: Coyote Creek Bridge Geotechnical Exploration		Prepared by: Aaron J. Miller, P.E.	Date: 12-Aug-2009	Structural
Component: Bridge Equipment Loading Analysis		Checked by: Ching-Liu Wu, S.E.	Date: 13-Aug-2009	
Calculation No: SGENS01	Rev. No. A			Sheet No.: 22 of 33

Bridge Inspection Truck Loading

The first equipment loading on the bridge will be the Bronto Bridge Inspection Truck to locate the desired coring location in the bridge deck. The following loading assumptions are checked for outrigger punching shear. The truck dead load of 25,000 lbs is distributed 1/3 to the front outriggers and 2/3 to the rear split equally between each bearing. Supporting information about the truck layout and loading provided by Boart Longyear is included in the Attachments.

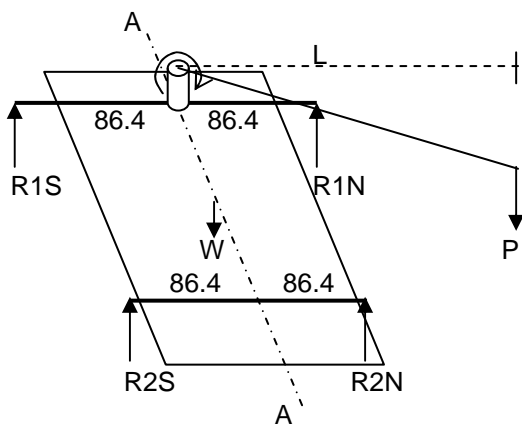

Assume that the boom length is 49 feet with a maximum reach of 40 feet and load of two times the platform capacity 1,200 lbs. Require that all the additional load imparted by the eccentric boom load is concentrated in either of the loaded side outrigger at one time.

L	40	ft
P	1200	lbs
R1S	n/a	
R2S	n/a	
R1N	6.67	kip
R2N	6.67	kip

$$\Sigma M_{A-A} = 1.2 * 40 + R1N * 7.2 = 0$$

$$\Rightarrow R1N = \frac{48}{7} = 6.67 \text{ kips}$$

$$\Sigma M_{A-A} = 1.2 * 40 + R2N * 7.2 = 0$$

$$\Rightarrow R2N = \frac{48}{7} = 6.67 \text{ kips}$$



SILICON VALLEY RAPID TRANSIT PROJECT

P0503-D300 CENTRAL AREA GUIDEWAY

HMM/Bechtel

Subject: Coyote Creek Bridge Geotechnical Exploration		Prepared by: Aaron J. Miller, P.E.	Date: 12-Aug-2009	Discipline: Structural
Component: Bridge Equipment Loading Analysis		Checked by: Ching-Liu Wu, S.E.	Date: 13-Aug-2009	
Calculation No: SGENS01	Rev. No. A			Sheet No.: 23 of 33

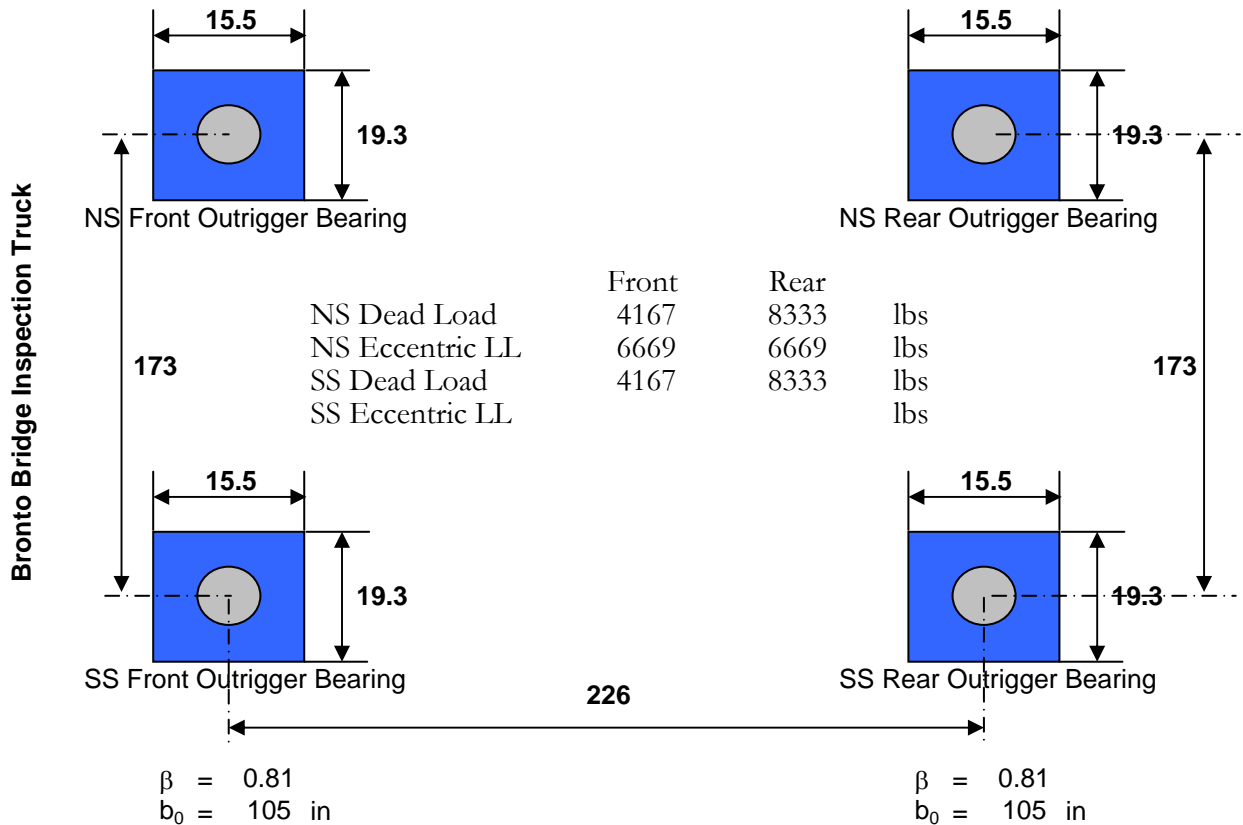

Front Bearings

$$V_c = \left[2 + \frac{4}{1} \right] * 1 * \sqrt{2500} * 105 * 8.75 = 319 \text{ kips} \quad \text{ACI 318}$$

$$V_c = \left[\frac{350}{105} + 2 \right] * 1 * \sqrt{2500} * 105 * 8.75 = 245 \text{ kips} \quad \text{ACI 318}$$

$$V_c = 4 * 1 * \sqrt{2500} * 105 * 8.75 = 183 \text{ kips} \quad \text{ACI 318}$$

$$v_c = \left[0.8 + \frac{2}{1} \right] * \sqrt{2500} = 164 \text{ psi} < 1.8 * \sqrt{2500} = 90 \text{ psi} \quad \text{Caltrans BDS}$$

Maximum	$\phi V_n =$	137.16	kips	
	$V_u =$	15.67	kips	OK ACI 318-08 PUNCHING SHEAR CHECK
	$v_c =$	90.00	psi	
Maximum	$v =$	11.85	psi	OK Caltrans BDS PUNCHING SHEAR CHECK



SILICON VALLEY RAPID TRANSIT PROJECT

P0503-D300 CENTRAL AREA GUIDEWAY

HMM/Bechtel

Subject: Coyote Creek Bridge Geotechnical Exploration		Prepared by: Aaron J. Miller, P.E.	Date: 12-Aug-2009	Discipline: Structural
Component: Bridge Equipment Loading Analysis		Checked by: Ching-Liu Wu, S.E.	Date: 13-Aug-2009	
Calculation No: SGENS01	Rev. No. A			Sheet No.: 24 of 33

Rear Bearings	$V_c = \left[2 + \frac{4}{1} \right] * 1 * \sqrt{2500} * 105 * 8.75 = 319 \text{ kips}$	ACI 318
	$V_c = \left[\frac{350}{105} + 2 \right] * 1 * \sqrt{2500} * 105 * 8.75 = 245 \text{ kips}$	ACI 318
	$V_c = 4 * 1 * \sqrt{2500} * 105 * 8.75 = 183 \text{ kips}$	ACI 318
	$v_c = \left[0.8 + \frac{2}{1} \right] * \sqrt{2500} = 164 \text{ psi} < 1.8 * \sqrt{2500} = 90 \text{ psi}$	Caltrans BDS

	$\phi V_n = 137.16 \text{ kips}$				
Maximum	$V_u = 20.67 \text{ kips}$	OK	ACI 318-08 PUNCHING SHEAR CHECK		
	$v_c = 90.00 \text{ psi}$				
Maximum	$v = 16.41 \text{ psi}$	OK	Caltrans BDS PUNCHING SHEAR CHECK		

Boom Truck Loading

The second equipment loading on bridge will be the Stinger BT3470 Boom Truck Crane to off-load the pallets of sandbags to the creek level. The following loading assumptions are checked for outrigger punching shear. Assumed that in addition to the crane dead load of 33,000 lbs the truck carries 5,000 lbs of sand bags and pallets. This additional load is distributed 1/3 to the front axle and 2/3 to the rear axle and then equally split between bearings. Supporting information about the truck layout and loading provided by Boart Longyear is included in the Attachments.

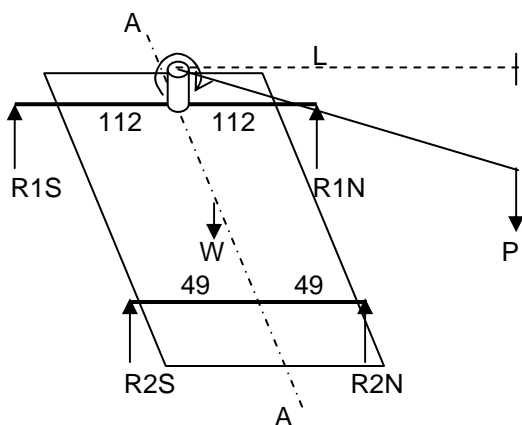

Assume that the boom length is 43 feet with a maximum reach of 40 feet and load of 3,500 lbs. Require that all the additional load imparted by the eccentric boom load is concentrated in either of the loaded side outrigger at one time.

L	40	ft
P	3500	lbs
R1S	n/a	
R2S	n/a	
R1N	15	kip
R2N	34.3	kip

$$\sum M_{A-A} = 3.5 * 40 + R1N * 9.33 = 0$$

$$\Rightarrow R1N = \frac{140}{9} = 15 \text{ kips}$$



SILICON VALLEY RAPID TRANSIT PROJECT

P0503-D300 CENTRAL AREA GUIDEWAY

HMM/Bechtel

Subject: Coyote Creek Bridge Geotechnical Exploration		Prepared by: Aaron J. Miller, P.E.	Date: 12-Aug-2009	Structural
Component: Bridge Equipment Loading Analysis		Checked by: Ching-Liu Wu, S.E.	Date: 13-Aug-2009	
Calculation No: SGENS01	Rev. No. A			Sheet No.: 25 of 33

$$\Sigma M_{A-A} = 3.5 * 40 + R2N * 4.08 = 0$$

$$\Rightarrow R2N = \frac{140}{4} = 34.3 \text{ kips}$$

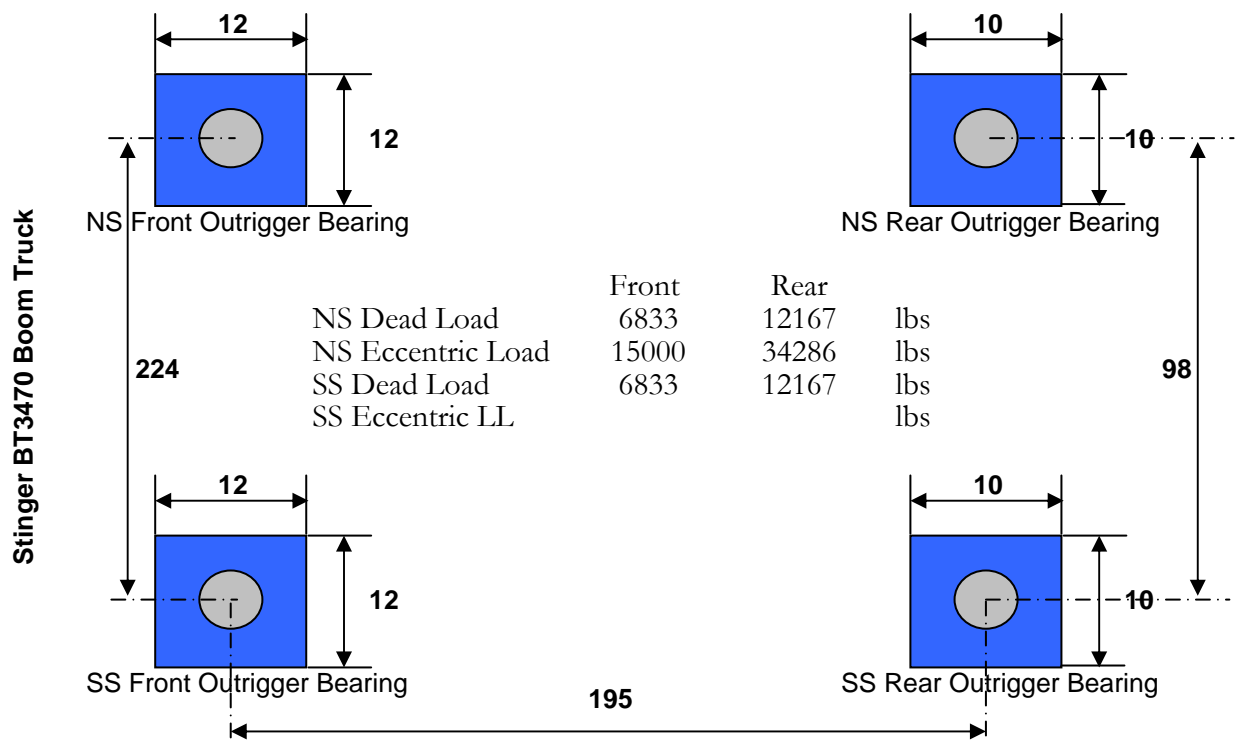

$$\beta = 1$$

$$b_0 = 83 \text{ in}$$

$$\beta = 1$$

$$b_0 = 75 \text{ in}$$

Front Bearings	$V_c = \left[2 + \frac{4}{1} \right] * 1 * \sqrt{2500} * 83 * 8.75 = 218 \text{ kips}$	ACI 318
	$V_c = \left[\frac{350}{83} + 2 \right] * 1 * \sqrt{2500} * 83 * 8.75 = 226 \text{ kips}$	ACI 318
	$V_c = 4 * 1 * \sqrt{2500} * 83 * 8.75 = 145 \text{ kips}$	ACI 318
	$v_c = \left[0.8 + \frac{2}{1} \right] * \sqrt{2500} = 140 \text{ psi} < 1.8 * \sqrt{2500} = 90 \text{ psi}$	Caltrans BDS

	$\phi V_n = 108.94 \text{ kips}$			
Maximum	$V_u = 32.20 \text{ kips}$	OK	ACI 318-08 PUNCHING SHEAR CHECK	
	$v_c = 90.00 \text{ psi}$			
Maximum	$v = 33.27 \text{ psi}$	OK	Caltrans BDS PUNCHING SHEAR CHECK	



SILICON VALLEY RAPID TRANSIT PROJECT

P0503-D300 CENTRAL AREA GUIDEWAY

HMM/Bechtel

Subject: Coyote Creek Bridge Geotechnical Exploration		Prepared by: Aaron J. Miller, P.E.	Date: 12-Aug-2009	Structural
Component: Bridge Equipment Loading Analysis		Checked by: Ching-Liu Wu, S.E.	Date: 13-Aug-2009	
Calculation No: SGENS01	Rev. No. A			Sheet No.: 26 of 33

Rear Bearings	$V_c = \left[2 + \frac{4}{1} \right] * 1 * \sqrt{2500} * 75 * 8.75 = 197 \text{ kips} \quad \text{ACI 318}$
	$V_c = \left[\frac{350}{75} + 2 \right] * 1 * \sqrt{2500} * 75 * 8.75 = 219 \text{ kips} \quad \text{ACI 318}$
	$V_c = 4 * 1 * \sqrt{2500} * 75 * 8.75 = 131 \text{ kips} \quad \text{ACI 318}$
	$v_c = \left[0.8 + \frac{2}{1} \right] * \sqrt{2500} = 140 \text{ psi} < 1.8 * \sqrt{2500} = 90 \text{ psi} \quad \text{Caltrans BDS}$
Maximum	$\phi V_n = 98.44 \text{ kips}$ $V_u = 69.46 \text{ kips} \quad \text{OK} \quad \text{ACI 318-08 PUNCHING SHEAR CHECK}$ $v_c = 90.00 \text{ psi}$
Maximum	$v = 70.78 \text{ psi} \quad \text{OK} \quad \text{Caltrans BDS PUNCHING SHEAR CHECK}$

Drill Rig Truck Loading

The third equipment loading on site will be the drill rig Boom Truck Crane to bore the exploratory samples. The following loading assumptions are checked for outrigger punching shear. Assume that 1/3 of the 37,000 lbs truck load is equally distributed over all three bearings with the addition of 1/2 of 18,000 lbs split between the two rear bearings.

Supporting information about the truck layout and loading provided by Boart Longyear is included in the Attachments.

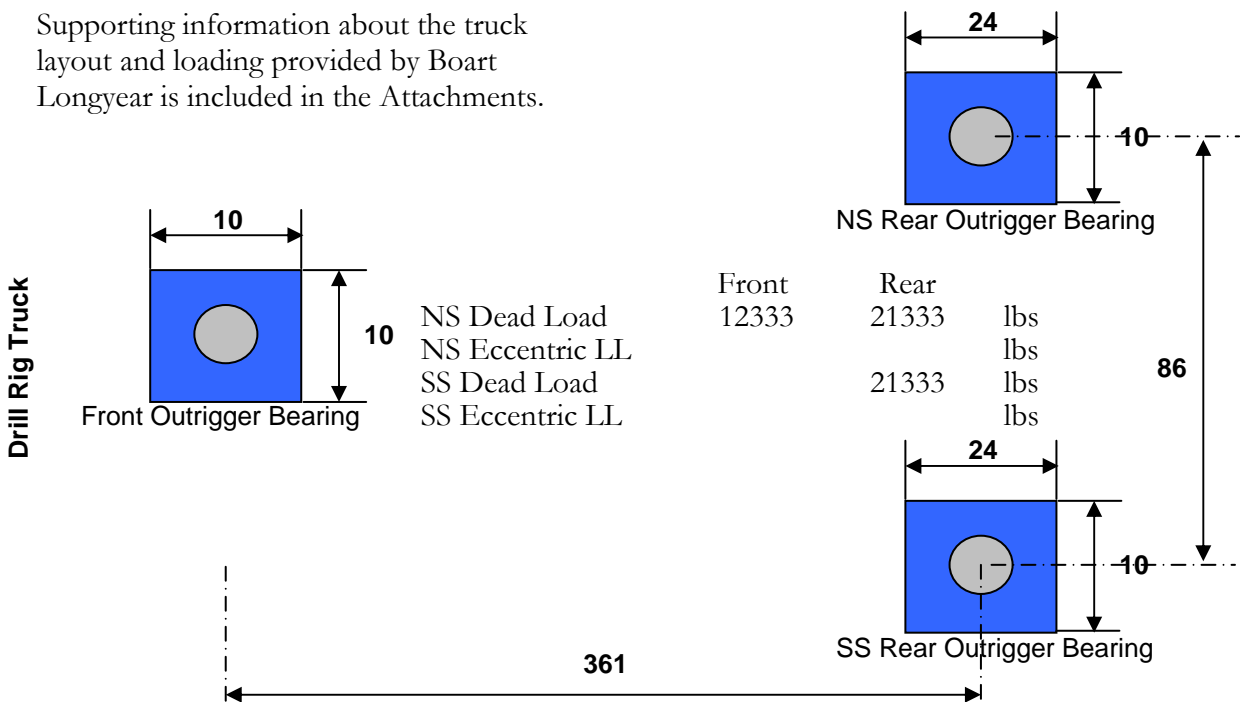



SILICON VALLEY RAPID TRANSIT PROJECT

P0503-D300 CENTRAL AREA GUIDEWAY

HMM/Bechtel

Subject: Coyote Creek Bridge Geotechnical Exploration		Prepared by: Aaron J. Miller, P.E.	Date: 12-Aug-2009	Structural
Component: Bridge Equipment Loading Analysis		Checked by: Ching-Liu Wu, S.E.	Date: 13-Aug-2009	
Calculation No: SGENS01	Rev. No. A			Sheet No.: 27 of 33

$$\beta = 1$$

$$b_0 = 75 \text{ in}$$

$$\beta = 2.4$$

$$b_0 = 103 \text{ in}$$

Front Bearings	$V_c = \left[2 + \frac{4}{1} \right] * 1 * \sqrt{2500} * 75 * 8.75 = 197 \text{ kips}$	ACI 318
	$V_c = \left[\frac{350}{75} + 2 \right] * 1 * \sqrt{2500} * 75 * 8.75 = 219 \text{ kips}$	ACI 318
	$V_c = 4 * 1 * \sqrt{2500} * 75 * 8.75 = 131 \text{ kips}$	ACI 318
	$v_c = \left[0.8 + \frac{2}{1} \right] * \sqrt{2500} = 140 \text{ psi} < 1.8 * \sqrt{2500} = 90 \text{ psi}$	Caltrans BDS

Maximum $\phi V_n = 98.44 \text{ kips}$	$V_u = 14.80 \text{ kips}$	OK	ACI 318-08 PUNCHING SHEAR CHECK
Maximum $v_c = 90.00 \text{ psi}$	$v = 13.68 \text{ psi}$	OK	Caltrans BDS PUNCHING SHEAR CHECK

Rear Bearings	$V_c = \left[2 + \frac{4}{2} \right] * 1 * \sqrt{2500} * 103 * 8.75 = 165 \text{ kips}$	ACI 318
	$V_c = \left[\frac{350}{103} + 2 \right] * 1 * \sqrt{2500} * 103 * 8.75 = 243 \text{ kips}$	ACI 318
	$V_c = 4 * 1 * \sqrt{2500} * 103 * 8.75 = 180 \text{ kips}$	ACI 318
	$v_c = \left[0.8 + \frac{2}{2} \right] * \sqrt{2500} = 81.7 \text{ psi} < 1.8 * \sqrt{2500} = 90 \text{ psi}$	Caltrans BDS

Maximum $\phi V_n = 123.92 \text{ kips}$	$V_u = 25.60 \text{ kips}$	OK	ACI 318-08 PUNCHING SHEAR CHECK
Maximum $v_c = 81.67 \text{ psi}$	$v = 23.67 \text{ psi}$	OK	Caltrans BDS PUNCHING SHEAR CHECK

Drill Rig Support Truck Loading

Accompanying the drill rig equipment will be a support truck. The following loading assumptions are checked for outrigger punching shear. Assume that the dead load of the truck is 34,000 distributed 1/3 to the front outriggers and 2/3 to the rear and split equally between bearings. Supporting information about the truck layout and loading provided by Boart Longyear is included in the Attachments.



SILICON VALLEY RAPID TRANSIT PROJECT

P0503-D300 CENTRAL AREA GUIDEWAY

HMM/Bechtel

Subject: Coyote Creek Bridge Geotechnical Exploration		Prepared by: Aaron J. Miller, P.E.		Date: 12-Aug-2009	Structural
Component: Bridge Equipment Loading Analysis		Checked by: Ching-Liu Wu, S.E.		Date: 13-Aug-2009	
Calculation No.: SGENS01		Rev. No.: A			Sheet No.: 28 of 33

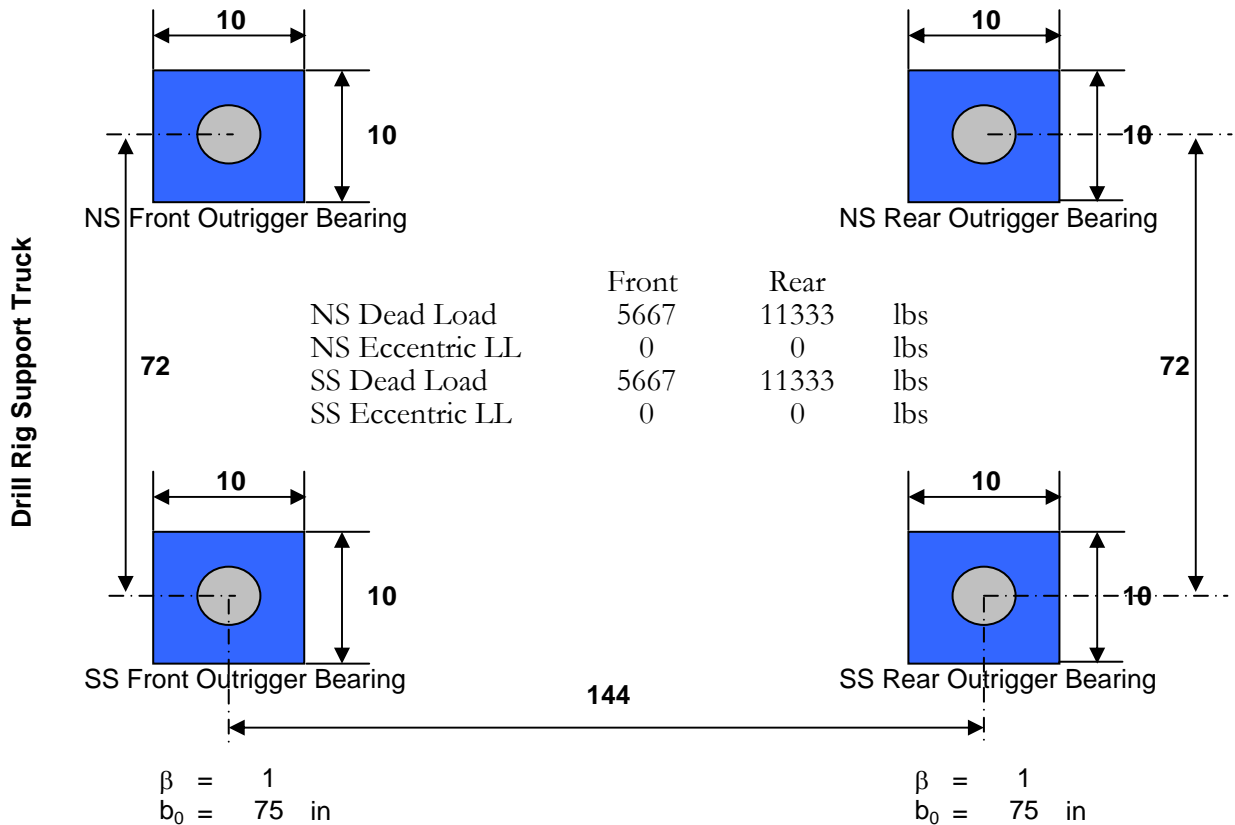

$\beta = 1$
 $b_0 = 75 \text{ in}$

$\beta = 1$
 $b_0 = 75 \text{ in}$

Front Bearings

$V_c = \left[2 + \frac{4}{1} \right] * 1 * \sqrt{2500} * 75 * 8.75 = 197 \text{ kips}$	ACI 318
$V_c = \left[\frac{350}{75} + 2 \right] * 1 * \sqrt{2500} * 75 * 8.75 = 219 \text{ kips}$	ACI 318
$V_c = 4 * 1 * \sqrt{2500} * 75 * 8.75 = 131 \text{ kips}$	ACI 318
$v_c = \left[0.8 + \frac{2}{1} \right] * \sqrt{2500} = 140 \text{ psi}$	$< 1.8 * \sqrt{2500} = 90 \text{ psi}$ Caltrans BDS

	$\phi V_n =$	98.44	kips		
Maximum	$V_u =$	6.80	kips	OK	ACI 318-08 PUNCHING SHEAR CHECK
	$v_c =$	90.00	psi		
Maximum	$v =$	8.63	psi	OK	Caltrans BDS PUNCHING SHEAR CHECK



SILICON VALLEY RAPID TRANSIT PROJECT

P0503-D300 CENTRAL AREA GUIDEWAY

HMM/Bechtel

Subject: Coyote Creek Bridge Geotechnical Exploration		Prepared by: Aaron J. Miller, P.E.	Date: 12-Aug-2009	Structural
Component: Bridge Equipment Loading Analysis		Checked by: Ching-Liu Wu, S.E.	Date: 13-Aug-2009	
Calculation No: SGENS01	Rev. No. A			Sheet No.: 29 of 33

Rear Bearings	$V_c = \left[2 + \frac{4}{1} \right] * 1 * \sqrt{2500} * 75 * 8.75 = 197 \text{ kips} \quad \text{ACI 318}$
	$V_c = \left[\frac{350}{75} + 2 \right] * 1 * \sqrt{2500} * 75 * 8.75 = 219 \text{ kips} \quad \text{ACI 318}$
	$V_c = 4 * 1 * \sqrt{2500} * 75 * 8.75 = 131 \text{ kips} \quad \text{ACI 318}$
	$v_c = \left[0.8 + \frac{2}{1} \right] * \sqrt{2500} = 140 \text{ psi} < 1.8 * \sqrt{2500} = 90 \text{ psi} \quad \text{Caltrans BDS}$
Maximum	$\phi V_n = 98.44 \text{ kips}$ $V_u = 13.60 \text{ kips} \quad \text{OK} \quad \text{ACI 318-08 PUNCHING SHEAR CHECK}$ $v_c = 90.00 \text{ psi}$
Maximum	$v = 17.27 \text{ psi} \quad \text{OK} \quad \text{Caltrans BDS PUNCHING SHEAR CHECK}$

Bridge Deck Coring Restoration Detail Check

The objective of the Geotechnical Exploration Program at Coyote Creek is to retrieve soil sample with a drilling auger through the bridge deck. Upon completion of this exploration the bore hole through the deck will be restored with a concrete plug so that the bridge lane can be returned to traffic. The following calculation evaluates the future traffic loads on the proposed concrete deck patch to ensure sufficient shear capacity.

Caltrans BDS Section 3.7 Highway Loads, Article 3.7.6 HS Loading requires that a concentrated load of 26,000 lbs be distributed across the lane. This concentrated load shall be uniformly distributed over a 10 foot width of lane normal to the centerline of the lane per the provisions of 3.7.1.2. The following models the maximum allowable concentrated load over the bridge deck lane where the boring patch is to be constructed.

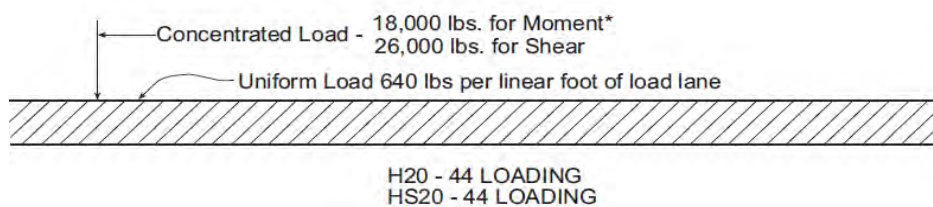

Caltrans BDS-04
(Figure 3.7.6B)

$$P = 1.6 * 26$$

$$P = 41.6 \text{ kips}$$



SILICON VALLEY RAPID TRANSIT PROJECT

P0503-D300 CENTRAL AREA GUIDEWAY

HMM/Bechtel

Subject: Coyote Creek Bridge Geotechnical Exploration		Prepared by: Aaron J. Miller, P.E.	Date: 12-Aug-2009	Discipline: Structural
Component: Bridge Equipment Loading Analysis		Checked by: Ching-Liu Wu, S.E.	Date: 13-Aug-2009	
Calculation No: SGENS01	Rev. No. A			Sheet No.: 30 of 33

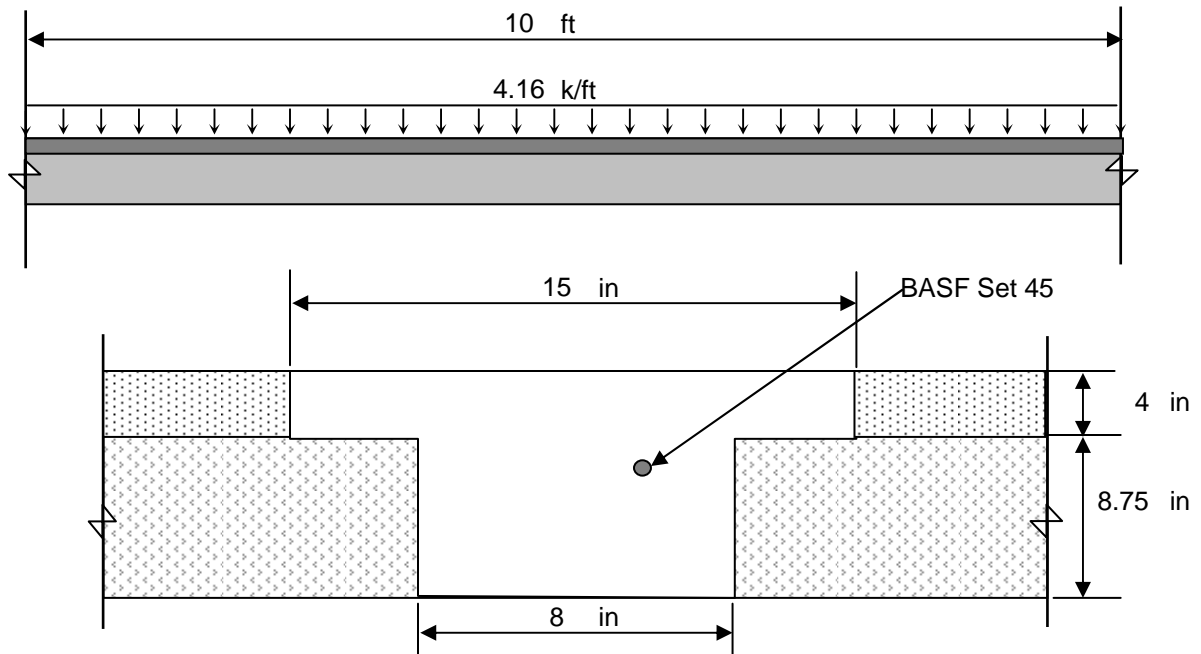

Two approaches are evaluated for potential shear paths from a concentrated load assumed to act at the center of restoration patch as shown below. The first analysis evaluates the top section of the patch for shear failure and the second analysis evaluates the shear failure of the inner core of the patch. The shear demand for each analysis is compared with the allowable shear stress, v_c as defined by Article 8.15.5.2.1 of the Caltrans BDS.

$$v_c = 0.95 \sqrt{f'_c}$$

$$v_c = 0.95 \sqrt{5000} = 67.2 \text{ psi}$$

$$P = 4.16 * \frac{8}{12} = 2.77 \text{ kips}$$

$$V_{\text{area}} = 3.14 * 4 \sqrt{16 * 16} = 71.1 \text{ in}^2$$

$$\gamma_1 = \frac{2773}{71.1} = 39 \text{ psi OK}$$

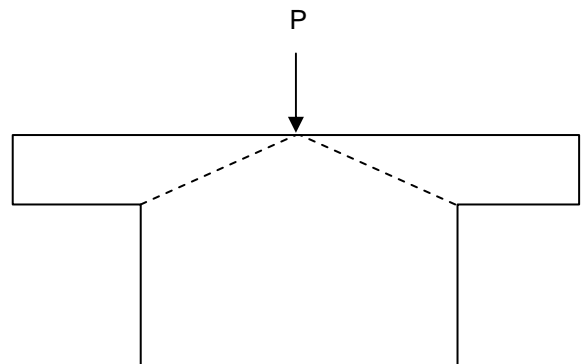



SILICON VALLEY RAPID TRANSIT PROJECT

P0503-D300 CENTRAL AREA GUIDEWAY

HMM/Bechtel

Subject: Coyote Creek Bridge Geotechnical Exploration		Prepared by: Aaron J. Miller, P.E.	Date: 12-Aug-2009	Discipline: Structural
Component: Bridge Equipment Loading Analysis		Checked by: Ching-Liu Wu, S.E.	Date: 13-Aug-2009	
Calculation No: SGENS01	Rev. No. A			Sheet No.: 31 of 33

The second approach assumes that only the lower portion of the patch resists shear, neglecting the depth of the top section analyzed in the first approach.

$$P = 4.16 * \frac{8}{12} = 2.77 \text{ kips}$$

$$V_{\text{area}} = 3.14 * 8 * 8.75 = 220 \text{ in}^2$$

$$\gamma_1 = \frac{2773}{220} = 12.6 \text{ psi OK}$$

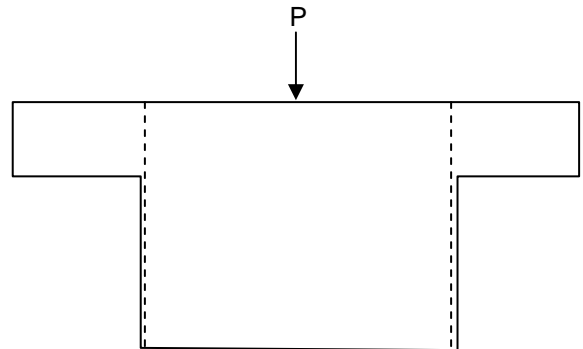

Although the capacity results from both of the restoration patch shear modeling approaches were sufficient for the required loading, an additional measure of shear strength is deemed to be in good practice. The addition of 2 - #4 bar in each direction in the top enlarged portion of restoration patch, centered in this depth will provide additional shear capacity to prevent cosmetic crack potential. The following calculation is based on Caltrans BDS 8.15.5.3.2 as an approximation only.

$$A_v = \frac{(v - v_c) b_w s}{f_s} \quad (\text{Caltrans BDS 08-03, Eq. 8-7})$$

$$f_s = 20 \text{ ksi}$$

$$A_v = \frac{0.24 - 0.07}{20} * 8 * 6 = 0.4 \text{ in}^2$$

Use 2-#4 bar 12" in length 6" spacing in each direction centered over the hole and in the center of the asphalt thickness.

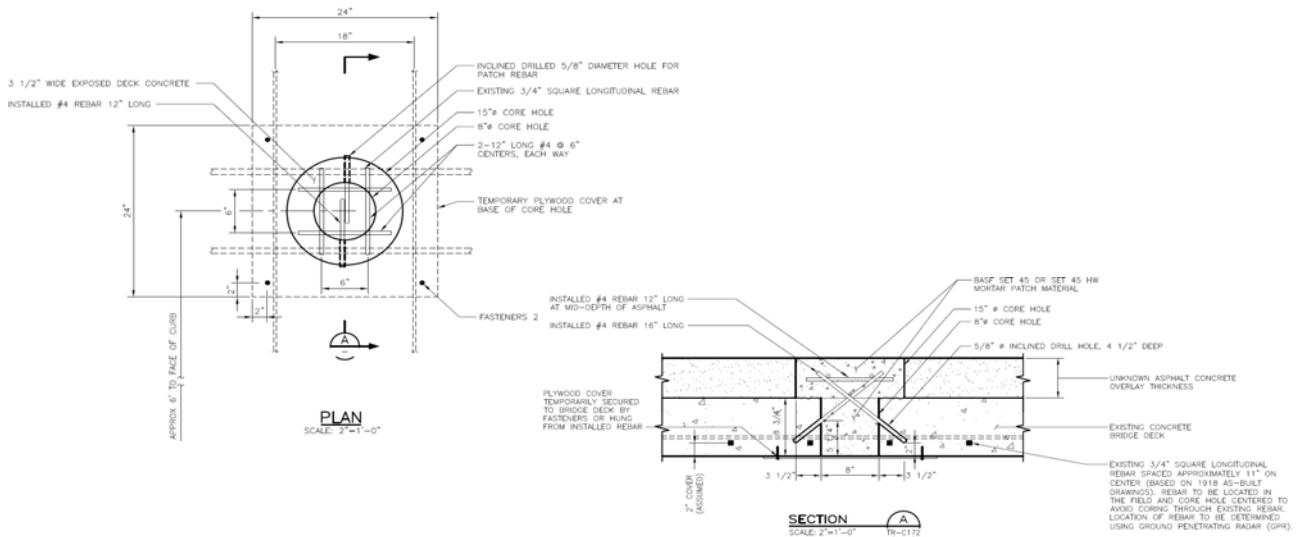



SILICON VALLEY RAPID TRANSIT PROJECT

P0503-D300 CENTRAL AREA GUIDEWAY

HMM/Bechtel

Subject: Coyote Creek Bridge Geotechnical Exploration		Prepared by: Aaron J. Miller, P.E.	Date: 12-Aug-2009	Discipline: Structural
Component: Bridge Equipment Loading Analysis		Checked by: Ching-Liu Wu, S.E.	Date: 13-Aug-2009	
Calculation No: SGENS01	Rev. No. A			Sheet No.: 32 of 33

Calculation Conclusions

The conclusions of the Geotechnical Exploration Program Coyote Creek Bridge Loading Analysis, which evaluates the temporary equipment loading demands on the Coyote Creek Bridge as described herein, are that the bridge has sufficient flexural and shear capacity to support these demands. Special precaution should be exercised to protect the bridge deck in the contact areas for each of the outrigger placements. When feasible, the outriggers should be placed over either Girder 1 or Girder 2. Careful attention to the curb edge and sidewalk surface to prevent damage to the concrete surface is required during all equipment operations on the bridge.

The restoration patch to enclose the borehole through the existing bridge was also evaluated for future traffic loading. The design recommendations include 5000 psi BASF Set 45 chemical action mortar with #4 rebar reinforcement for mechanical connection and additional shear strength. Design drawing TR—C172 in the Attachments provides the design details for the restoration patch.



SILICON VALLEY RAPID TRANSIT PROJECT

P0503-D300 CENTRAL AREA GUIDEWAY

HMM/Bechtel

Subject: Coyote Creek Bridge Geotechnical Exploration		Prepared by: Aaron J. Miller, P.E.	Date: 12-Aug-2009	Discipline: Structural
Component: Bridge Equipment Loading Analysis		Checked by: Ching-Liu Wu, S.E.	Date: 13-Aug-2009	
Calculation No: SGENS01	Rev. No. A			Sheet No.: 33 of 33

Attachments

The following attachments include the supporting equipment information provided by Boart Longyear for the bridge analysis.

Email Correspondents:

August 10, 2009 FW:Emailing:P1010107.JPG,P1010108.JPG.....
August 8, 2009 RE: Coyote Creek Bridge Boring
July 29, 2009 RE: Support Truck
July 15, 2009 RE: Equipment rental quotes
July 13, 2009 RE: Loads

Sketches/Other:

Work Plan: Geotechnical Exploration Program Coyote Creek, July 24, 2009
1918 Bridge Plans for City of San Jose
August 4, 2009 Drill Rig outrigger layout sketch from Boart Longyear
August 4, 2009 Support Truck outrigger layout sketch from Boart Longyear
Crane Truck Terex BT3470 Load Chart
Bronto Bridge Inspection Truck Cut Sheet
Sketch of Exploratory Boring Restoration Patch

Miller, Aaron

From: Foster, Brett [Brett.Foster@boartlongyear.com]
Sent: Monday, August 10, 2009 3:28 PM
To: Miller, Aaron
Cc: Isaacson, Jon
Subject: FW: Emailing: P1010107.JPG, P1010108.JPG, P1010109.JPG, P1010110.JPG, P1010111.JPG, P1010112.JPG
Attachments: P1010107.JPG; P1010108.JPG; P1010109.JPG; P1010110.JPG; P1010111.JPG; P1010112.JPG

Aaron here is all the info for the bridge inspection unit along with the reach charts you should be able to answer any engineering questions that may arise. Also the 86" is center to center and center line of the truck.

Brett

Let me know if there is anything else you need.

From: Patty Neri [mailto:admin@alasher.com]
Sent: Friday, August 07, 2009 4:57 PM
To: Foster, Brett
Subject: Emailing: P1010107.JPG, P1010108.JPG, P1010109.JPG, P1010110.JPG, P1010111.JPG, P1010112.JPG

Dear Mr. Foster:

Attached are actual photographs taken this afternoon of the bridge unit.

The measurements are as follows:

CENTERLINE OF TRUCK TO OUTER MEASUREMENT OF OUTRIGGER PAD: 8 FT.

OUTSIDE LEFT TO OUTSIDE RIGHT OUTRIGGER: 186 IN.
 INSIDE LEFT TO INSIDE RIGHT OUTRIGGER: 147 1/2 IN.

OUTSIDE FRONT TO OUTSIDE REAR OUTRIGGER: 241 1/2 IN.
 INSIDE FRONT TO INSIDE REAR OUTRIGGER: 209 7/8 IN.

OUTRIGGER DIMENSIONS: 15 1/2 IN. WIDE X 19 1/4 IN. DEEP

TRUCK MEASUREMENTS ARE: 31 FT. LONG (BUMPER TO BUMPER) X 11 FT. 7 IN. HIGH X 8 FT. WIDE

The overhang of the boom in the stowed position at the front of the unit is 4 1/2 feet.

Please feel free to contact me if you have any questions or require additional information.

Best Regards,

Patty Neri

PN/s

8/12/2009

Enc.

The message is ready to be sent with the following file or link attachments:

P1010107.JPG
P1010108.JPG
P1010109.JPG
P1010110.JPG
P1010111.JPG
P1010112.JPG

Note: To protect against computer viruses, e-mail programs may prevent sending or receiving certain types of file attachments. Check your e-mail security settings to determine how attachments are handled.

This email has been scanned by the MessageLabs Email Security System.
For more information please visit <http://www.messagelabs.com/email>

Miller, Aaron

From: Foster, Brett [Brett.Foster@boartlongyear.com]
Sent: Thursday, August 06, 2009 6:00 PM
To: Miller, Aaron
Subject: RE: Coyote Creek Bridge Boring
Attachments: Terex BT3470 Load Chart.pdf

Aaron here is info on the crane still working on Snooper truck,
You asked for the outrigger spacing on our drill the rears are 86”

I will get you more info as soon as I have it in hand.

Brett

From: Miller, Aaron [mailto:Aaron.Miller@hatchmott.com]
Sent: Wednesday, August 05, 2009 7:26 AM
To: Foster, Brett
Cc: Fong, Dave; Isaacson, Jon
Subject: Coyote Creek Bridge Boring

Hi Brett,

It was nice meeting you and your guys yesterday at the subject meeting. We spoke afterwards regarding dimensional locations and maximum load values for the different load requirements of the equipment you plan to place on the bridge deck for the boring work. Please send me this information when get a chance so that I can check the demands on the existing structure. Dave has provided you a spreadsheet with an example of the necessary information we need to complete an analysis. If you have any questions, please don't hesitate to call.

Regards,

Aaron

Aaron J. Miller, P.E., LEED AP
181 Metro Drive, Suite 510
San Jose, CA 94588
T. (408) 572-8795
F. (408) 572-8799
E. aaron.miller@hatchmott.com



Please consider the environment before printing this e-mail

Attention:

This e-mail and any files transmitted with it from Hatch Mott MacDonald are confidential and intended solely for use of the individual or entity to whom they are addressed. If you have received this e-mail in error please immediately notify the sender.

This email has been scanned by the MessageLabs Email Security System.
For more information please visit <http://www.messagelabs.com/email>

8/12/2009

From: Hacker, Rick [rhacker@boartlongyear.com]

Sent: Wednesday, July 29, 2009 11:44 AM

To: Isaacson, Jon

Cc: Foster, Brett

Subject: RE: Support Truck

Support Truck Will have the same wheel spacing as the Rig Max weight 35,000 Lbs, Width 8'

From: Isaacson, Jon [mailto:Jon.Isaacson@hatchmott.com]

Sent: Wednesday, July 29, 2009 11:40 AM

To: Foster, Brett; Hacker, Rick

Subject: Support Truck

Brett and Rick,

My structural engineer is going over the vehicle loadings on the bridge. Aside from the drill rig, you plan to use a support truck right? How big and heavy of a support truck to carry the extra equipment? Wheel spacing, vehicle length and width, and loaded weight are what we'd need. Otherwise we'll have to assume a conservative traffic load, which might not work.

It appears we have enough for all of the other equipment.

See you next week,

Ike

J. Ike Isaacson, CEG 2527, PG 7919, PE

Tunnel Engineer

Hatch Mott MacDonald

Pleasanton Office 925-469-8022

SVRT Milpitas Office 408-942-6157

jon.isaacson@hatchmott.com

Attention:

This e-mail and any files transmitted with it from Hatch Mott MacDonald are confidential and intended solely for use of the individual or entity to whom they are addressed. If you have received this e-mail in error please immediately notify the sender.

This email has been scanned by the MessageLabs Email Security System.

For more information please visit <http://www.messagelabs.com/email>

From: Foster, Brett [Brett.Foster@boartlongyear.com]
Sent: Wednesday, July 15, 2009 10:27 PM
To: Isaacson, Jon
Subject: RE: Equipment rental quotes
Ike the boom is immediately behind the cab.

From: Isaacson, Jon [Jon.Isaacson@hatchmott.com]
Sent: Wednesday, July 15, 2009 11:23 AM
To: Foster, Brett
Cc: dave.fong@vta.org
Subject: RE: Equipment rental quotes

Brett,

Can you find out if the boom pivot is mounted behind the cab or at the rear of the truck we plan to use? Also, we need to make sure they have enough line on the winch to lower loads 40 feet below the base of their tires.

Ike

J. Ike Isaacson, CEG 2527, PG 7919, PE
Tunnel Engineer
Hatch Mott MacDonald
Pleasanton Office 925-469-8022
SVRT Milpitas Office 408-942-6157
jon.isaacson@hatchmott.com

From: Foster, Brett [mailto:Brett.Foster@boartlongyear.com]
Sent: Monday, July 13, 2009 8:38 PM
To: Isaacson, Jon
Subject: FW: Equipment rental quotes

Crane truck specs on attachment

Sent: Tuesday, July 07, 2009 10:51 AM
To: Foster, Brett
Subject: RE: Equipment rental quotes

I have attached our spec sheet for one of our 17-ton boom truck (all three are the same truck and same crane). I am also sending the load chart for these trucks which will give you the wheel base (20') and other information. (See the third page) If you need any other information, please let me know.

--- On **Thu, 7/2/09, Foster, Brett** <Brett.Foster@boartlongyear.com> wrote:

From: Foster, Brett <Brett.Foster@boartlongyear.com>
Subject: RE: Equipment rental quotes
Date: Thursday, July 2, 2009, 12:23 PM

Doxsee thank you for the quote I will be in touch as soon as we get a firm schedule, can you please provide detailed rig specs for the 17 ton truck such as wheel base, outrigger spread, counter weights, etc the engineers have to do safety calcs. for the bridge.

Thanks Brett

This email has been scanned by the MessageLabs Email Security System.
For more information please visit <http://www.messagelabs.com/email>

Attention:

This e-mail and any files transmitted with it from Hatch Mott MacDonald are confidential and intended solely for use of the individual or entity to whom they are addressed. If you have received this e-mail in error please immediately notify the sender.

This email has been scanned by the MessageLabs Email Security System.
For more information please visit <http://www.messagelabs.com/email>

From: Foster, Brett [Brett.Foster@boartlongyear.com]

Sent: Monday, July 13, 2009 8:33 PM

To: Isaacson, Jon

Subject: RE: Loads

Ike here is some info on equipment...Under bridge inspection unit.

From: Isaacson, Jon [Jon.Isaacson@hatchmott.com]

Sent: Tuesday, June 30, 2009 3:04 PM

To: Foster, Brett; Hacker, Rick

Following is information I have obtained from the service writer regarding the Bronto Unit:

THE BASKET ON THE UNIT IS MADE OF STEEL. WE HAVE NOT WEIGHED IT, HOWEVER, THE MAXIMUM WEIGHT LOADED IN THE BASKET CANNOT EXCEED 600 LBS. THAT WOULD INCLUDE, OPERATOR(S), TOOLS AND OR EQUIPMENT. ADDITIONALLY, THE UNIT IS EQUIPPED WITH AN OVERLOAD PROTECTION SYSTEM.

THE UNIT HAS CONTINUOUS ROTATION IF FOUR OUTRIGGERS ARE PENETRATED. WITH TWO OUTRIGGERS EXTENDED, THE UNIT IS MORE RESTRICTED.

THE TRUCK WEIGHS APPROXIMATELY 25,000 LBS.

THE TRUCK IS EIGHT FEET WIDE. WITH BOTH OUTRIGGERS EXTENDED THE WIDTH WOULD BE APPROXIMATELY 12 FEET.

THE AERIAL IS A REAR MOUNTED UNIT.

THERE ARE NO COUNTERWEIGHTS ON THE UNIT

Cc: dave.fong@vta.org

Subject: Loads

Gentlemen,

Dave Fong is our structural engineer taking a look at the bridge and the work/patch plan. He needs some information to complete his review

1. Equipment weights, dimensions, axle spacings, and outrigger spacings for drill rig and support equipment to be used
2. Information on the boom truck (if you plan to use one to lower and retrieve sandbags from the bridge deck) such as pallet weight, boom or swing length, truck weight, outrigger and axle spacing, and location of pivot point of the truck relative to the outriggers or axles. Also any counterweights
3. Any other equipment or commodities with weight and footprint that are to be placed on the bridge during operations.

I also want to coordinate with you a revised timeline so that we can get a better idea of when traffic control will be needed.

Thanks,

Ike

J. Ike Isaacson, PE, PG 7919

Tunnel Engineer

Hatch Mott MacDonald

Pleasanton Office 925-469-8022

SVRT Milpitas Office 408-942-6157

jon.isaacson@hatchmott.com

Attention:

This e-mail and any files transmitted with it from Hatch Mott MacDonald are confidential and intended solely for use

of the individual or entity to whom they are addressed. If you have received this e-mail in error please immediately notify the sender.

This email has been scanned by the MessageLabs Email Security System.
For more information please visit <http://www.messagelabs.com/email>

WORK PLAN

GEOTECHNICAL EXPLORATION PROGRAM COYOTE CREEK

CENTRAL AREA GUIDEWAY OF SILICON VALLEY RAPID TRANSIT (SVRT) PROJECT SAN JOSE, CALIFORNIA

Prepared by:
HMM / BECHTEL

July 24, 2009

Project No. P0503

CONTENTS

	Page
1.0 INTRODUCTION.....	1
2.0 DRILLING PROGRAM	1
2.1 Program Description.....	1
2.1.1 Site Preparation.....	2
2.1.2 Borehole Positioning and Bridge Deck Coring	3
2.1.3 Preparation for Sonic Drilling.....	4
2.1.4 Sonic Drilling	5
2.1.5 Boring Completion and Abandonment	6
2.1.6 Storage and Disposal of Investigation Derived Waste	6
2.1.7 Bridge Deck Repair	6
2.1.8 Positioning and Survey.....	7
2.1.9 Site Cleanup and Restoration	8
2.2 Program Schedule.....	8
3.0 HEALTH, SAFETY AND ENVIRONMENTAL PLAN	8
4.0 TRAFFIC AND PEDESTRIAN CONTROL.....	8
5.0 COMMUNITY OUTREACH.....	9

FIGURES

	Plate
Figure 1	Location Map
Figure 2.....	Geotechnical Plan and Profile
Figure 3.....	Traffic Control and Work Site Staging Plan
Figure 4.....	Creek Protection/Diversion Plan
Figure 5.....	Bridge Coring and Restoration Plan
Figures 6 through 8.....	Boring Location Photos

1.0 INTRODUCTION

The purpose of this Work Plan is to describe the proposed Coyote Creek geotechnical field exploration program as part of the Silicon Valley Rapid Transit (SVRT) Project. This Work Plan specifically describes the investigation for a portion of the twin-bore tunnel alignment, which will pass beneath Coyote Creek near or along Santa Clara Street (see Figure 1, Sheet C-168).

A proposed boring, BH-107, is planned at Coyote Creek. The proposed location for BH-107 is shown on Figure 2 (Sheet C-169).

This Work Plan summarizes and discusses the proposed scope of work, methods, and procedures required to perform Boring BH-107. This Work Plan is organized as outlined below:

- Section 1.0 - Introduction
- Section 2.0 - Drilling Program
- Section 3.0 - Health, Safety and Environmental Plan
- Section 4.0 - Traffic and Pedestrian Control
- Section 5.0 - Community Outreach

2.0 DRILLING PROGRAM

2.1 PROGRAM DESCRIPTION

As shown on Figure 2, Boring BH-107 would be performed through a cased hole advanced through the deck of the Santa Clara Street Bridge at Coyote Creek, and down to a benched area on the east bank of Coyote Creek. This boring would be located between Piers 2 and 3. Because the drill rig, support vehicles, workers and drilling materials would all be located on the bridge deck, this boring location would result in minimal disturbance to the creek. The drilling work would require a lane of traffic on Santa Clara Street be closed for two to three days as shown in Figure 3 (Sheet C-170). A 6-foot high chain link fence will be placed to provide security for crew and equipment within the work site area on the bridge.

Work will be conducted during daylight hours and will be subject to the restrictions of the City of San Jose. Based on City requirements, the available working window would be on weekdays from 8:30 am to 3:30 pm for the segment along Santa Clara Street between 11th Street and Highway 101. To complete this work in an efficient manner, it may be necessary to leave the lane closure and equipment within the work area over night, although crews and equipment would not work outside the allowable working window hours. Standard flashing lights will be placed along the work zone to identify the overnight lane closure.

Drilling will take place between June and October, which is outside of the “rainy season”, and will be done “in the dry.” To prevent drilling water from flowing into the creek, or creek water

from flowing into the work area, a Creek Protection/Diversion Plan will be implemented. The plan involves the temporary construction of a circular sandbag cofferdam wall immediately around the site where the borehole casing will contact the native soils beneath the bridge. This small area can then be dewatered for drilling, minimizing the overall impact of the work. Figure 4 (Sheet C-171) presents the plan to protect Coyote Creek. The work would include restoration of the work area to its original conditions per all permit requirements.

A detailed discussion of the proposed work, equipment, and sequence/procedures for the proposed activity follows.

2.1.1 Site Preparation

The bench below the bridge possesses an area of ponded non-channel water between Piers 2 and 3, with an average depth between 8 and 18 inches. Prior to site work preliminary utility marking will occur both at deck level and beneath the bridge.

The core hole and boring location will be inspected to determine the presence of any utilities as follows:

1. Available utility location information will be gathered and documented on the alignment plans.
2. A designated representative (HMM/Bechtel field engineer) will visually inspect the presence of overhead utilities and any indicators of underground utilities and review the utility plans in the field. Evidence of overhead and underground utilities is not anticipated at this time. However, the proximity to overhead and underground utilities will be evaluated in the field at the time of field work and the borehole location will be moved to avoid any interference. After this preliminary utility evaluation is completed, the designated representative will outline the work location using approved paint as required by Underground Service Alert (USA) and City of San Jose.
3. Following the marking of the exploration location, the designated representative will comply with the requirements of USA, California Government Code 4216 (Assembly Bill No. 73) and California Business and Professions Code 7110 (Assembly Bill No. 2719) by calling USA a minimum of 72 hours prior to subsurface investigation of the site. A USA number will be obtained for the work area and documented in the project file.
4. USA will notify the appropriate agencies and, if utilities exist, their representatives will mark utilities within or near the work area.
5. In addition to USA notification, HMM/Bechtel will subcontract a private utility locator to confirm that utilities are not located within the area to be cored.
6. Hand auguring/potholing at the creek bench will be conducted to confirm utilities are not present in the upper 5 feet (refer to Sections 2.1.2 and 2.1.3)

If utilities are present in the general vicinity of the core hole or boring, a minimum of 2 feet of clearance between the drilled hole and any utilities will be required.

Once utilities have been identified and marked, sandbags that will be used to construct a circular cofferdam around the borehole location within the ponded water area will be delivered by pallets on a crane truck positioned in the north lanes of the bridge. The sandbag pallets will be lowered and placed by the crane truck in a landing zone on the ground below to minimize time. A temporary lane closure approximately 2 hours long is anticipated for the two northern lanes of the bridge during the crane truck delivery of sandbags. Utility clearances can be conducted prior to the work period, and delivery of sandbag materials is anticipated to take approximately 2 hours to complete.

2.1.2 Borehole Positioning and Bridge Deck Coring

Nondestructive testing using ground penetration radar (GPR) will be employed to locate rebar reinforcement within the bridge decking to identify a suitable location for coring to avoid hitting or cutting the rebar within the bridge deck. Scanning of the underside of the bridge deck will be made possible through the use of a bridge inspection truck, which possesses a basket for personnel at the end of a reverse-articulated boom capable of reaching the underside of the deck while parked atop the north lanes of the bridge. The inspection truck will also be utilized to catch any debris or cutting fluids which are issued from the underside of the deck during the coring operation. Due to the need for the inspection truck to conduct the scanning and coring work, daytime traffic control will be required for the northernmost lane to protect the scanning and coring operations and personnel.

Once a suitable core-hole location is identified by the GPR scanning, a catch basin or IDW barrel will be positioned beneath the coring location inside the inspection basket and a 9-inch diameter hole will then be cored through the bridge deck at approximately the center of the westbound outside (northernmost) lane. The core equipment consists of a 9-inch diamond core drilling bit and portable drill assembly. Minor amounts of water are used to cool the bit during the coring operation. The catch basin or barrel provides the ability to contain any falling debris and/or cutting fluid from the coring operation. In addition to coring the 9-inch diameter hole in the bridge deck, the upper portion of the core hole through the depth of the asphaltic concrete will be enlarged to 15 inches in diameter to establish a stepped hole and facilitate patching operations after completion of the boring. After coring is completed, the catch basin/barrel will be removed and inspection truck will be demobilized.

A plumb bob will be used to locate the drilling location at the ground surface immediately below the core hole location either prior to or after coring operations. Based on the plumb-bob position, a small, circular temporary sandbag cofferdam will then be installed within the ponded area centered at the indicated location. The area within the cofferdam will then be bailed dry of water and facilitate their five (5) foot deep, 3-inch diameter hole to be hand augured to confirm

that utilities are not present at the boring location, fulfilling the requirements of Item 6 of Section 2.1.1. Scanning and coring activities combined are anticipated to take nearly a day to complete. Sandbag placement for the circular cofferdam activity may also be accomplished by the end of that same day, or completed at the start of the following day. One day of single lane temporary lane closure is anticipated for these activities. At the completion of the day, a ¼” steel plate will be secured to the top of the bridge deck so that the north lane can be reopened to traffic until the following morning.

2.1.3 Preparation for Sonic Drilling

Once the circular sandbag cofferdam has been completed and bailed dry, the sonic drill crew will hand auger a five (5) foot deep, 3-inch diameter hole within the dewatered sandbag cofferdam to confirm that utilities are not present at the boring location. This material will be stockpiled on the dry area beneath the bridge and later used during hole closure. This activity may be completed on the same day as coring operations, but may also be completed on the following day prior to drilling. If this activity is being conducted on the day drilling will begin, traffic control fencing to facilitate the single lane closure on the bridge will also be implemented while hand-auguring work is performed beneath the bridge.

Once hand auguring has been completed and lane fencing is established, the sonic drill rig would mobilize and be positioned over the core hole in the bridge deck within the lane closure area with implemented traffic control. At that time the ¼” steel cover plate would be removed from its position over the core hole. Using the drill rig on the bridge deck, an approximately 8.5-inch diameter steel “conductor” casing will be lowered through the cored hole in the bridge deck down to the ground surface beneath the bridge directly over the previously hand augured hole within the sandbag cofferdam. The “conductor” casing will then be driven or hydraulically pushed approximately 3 feet into the native soil to establish a seal between the “conductor” casing and the soils. The 3 feet embedment seal will prevent drilling fluids or soil from escaping the cased hole. The sandbag cofferdam then provides for secondary containment of any seepage from the embedment seal of the conductor casing., further isolating the work area. The internal volume of the cofferdam will be such as to accommodate the maximum volume of fluid contained within the conductor casing above the cofferdam elevation. A drill tub would be placed around the top of the casing on top of the bridge deck to contain any drill spoils exiting the casing during drill operations.

Preparation work for the boring is anticipated to take 2 to 4 hours. Once the “conductor” casing is installed, the lane closure must remain in effect until the hole has been grouted and abandoned, a time span of approximately 2 1/2 days, which will likely require only two overnight lane closures.

2.1.4 Sonic Drilling

Geotechnical borings are routinely used to determine subsurface soil and groundwater conditions. The boring proposed at the Santa Clara Street Bridge over Coyote Creek will be 7 inches in diameter (nominal 6-inch diameter core recovered) and will be drilled with a truck-mounted drill rig. Samples of soil will be extracted from the ground and either tested in the field or transported to a laboratory for further testing (type, strength, and compressibility).

Sonic drilling is planned as the drilling method to obtain soil samples below Coyote Creek. The sonic drilling method provides representative, continuous core samples up to 6 inches in diameter. The larger diameter samples will allow HMM/Bechtel to determine the extent and particle size of granular alluvium in the “tunnel zone” (one tunnel diameter, approximately 20 feet, above and below the current alignment) at the Coyote Creek crossing.

A sonic drill head works by sending high frequency resonant vibrations down the drill string to the drill bit, while the operator controls these frequencies to suit the specific conditions of the soil/rock geology. Resonance magnifies the amplitude of the drill bit, which fluidizes the soil particles at the bit face, allowing for fast and easy penetration through most geological formations. An internal spring system isolates the vibration forces from the rest of the drill rig. Sonic drilling creates some noise and vibrations within a limited area of the drilling site. However, a carrier casing up to 3 feet below ground surface will shelter the vibrated casing. If noise or vibrations are a concern, a sonic monitoring system using instrumented probes could be implemented to confirm noise and vibration levels are at acceptable levels.

The truck-mounted drill rig will have an operational height of approximately 35 feet (with the mast raised). The drill rig is typically a 30 to 40-foot long truck, with a support truck to provide inner and outer casing. Drilling of the borehole is expected to take 2 to 3 days to complete.

All of the drilling will be completed from within a 8.5-inch steel “conductor” casing that would extend from the bridge deck to a distance about 3 feet below ground surface (bgs). All drilling fluids and soil cuttings generated during drilling operations will be collected using shovels, pumps, and/or vacuum and placed in 55-gallon drums located on the bridge deck, as detailed in Section 2.1.7. The drilling would extend approximately 90 feet below the ground surface below the bridge, and is anticipated to take 2 days to complete. Two overnight lane closures are anticipated based on the need to leave the drill rig over the borehole until it is completed.

Noise impacts, typically limited to the sound of a running diesel engine and the back-up warning beepers on vehicles, are typical. Part of the drilling process also includes intermittent noises from the sonic vibrations of the casing. In addition, the drill rig, trucks and/or trailers housing the equipment will be visible, and drums storing soil collected from the drilling process will be on the bridge during drilling activities until the borehole is completed. The core will be 6-inch diameter and drilling will proceed to maximize core recovery. Core recovery boxes will be

supplied on site to store all retrieved continuous-core samples. After sampling is completed, the core boxes will be transported to a storage facility offsite.

2.1.5 Boring Completion and Abandonment

Upon completion of the boring, the hole will be backfilled with cement-bentonite grout using a tremie pipe extending from the drill rig on the bridge deck. The boring will be filled from the bottom of the hole upward to a depth of approximately 3 feet below the ground surface (bgs) under the bridge. The backfilling of the hole with grout will be done in accordance with the requirements of the Santa Clara Valley Water District. Any fluid in the casing above the grout will be removed by the drill crew out of the casing at the bridge deck surface and placed in IDW barrels. Once the fluid is removed and the grout level is approximately 3 feet bgs, the outer casing will then be withdrawn and removed by the crew on the bridge deck. Below the bridge, additional hand-mixed grout will be added at the ground surface (i.e. not from the bridge deck) within the circular sandbag cofferdam to ensure the grout reaches a depth of 3 feet bgs. After the grout has set, the remaining 3 feet of the borehole will then be backfilled with the native material, which was stockpiled during the initial hand auguring of the upper 5 feet of soil as previously detailed in Section 2.1.3. The work area will then be restored to the original conditions that existed prior to drilling. The single lane closure and traffic control will be needed on the bridge deck until grouting has been completed from the top of the bridge, the “conductor” casing has been removed from the hole, and the clean-up of drilling area on the bridge deck has been completed and Investigation Derived Waste (IDW) barrels are removed. Removal of lane closure fencing will commence on the day the boring is completed and closed. It is anticipated that the repairs detailed in Section 2.1.7 could also be taking place during lane fencing removal, and should occur on the same day as drill rig demobilization from the bridge.

2.1.6 Storage and Disposal of Investigation Derived Waste

Investigation Derived Waste (IDW) generated during drilling operations will be pumped to the bridge surface or vacuumed out of the outer casing. IDW is not expected to be contaminated and will be handled as follows:

- All IDW will be placed in 55-gallon drums and sealed with bolted covers. Drums will be labeled with “Non-Hazardous” labels and field drum inventory reports will be produced and filed.
- Drums will be kept within the work area throughout the duration of work and, at the conclusion of work, will be disposed of by a licensed waste disposal company.

2.1.7 Bridge Deck Repair

After the sonic boring has been completed and backfilled, the sonic rig will be demobilized from the bridge and will depart the site. Since the “conductor” casing is no longer through the core

hole in the bridge deck, the bridge deck can now be repaired. The bridge deck will be repaired and restored to its original condition per City of San Jose permit requirements.

To repair the deck, the following procedure will be implemented:

- The bridge inspection truck will be remobilized onto the bridge and positioned to allow deck level access to the core hole location while being able to reach the underside of the deck at the same location.
- Using the bridge inspection boom, a cover board will be positioned beneath the base of the core hole flush against the underside of the bridge deck. This board may be held in place by either temporary anchors or held manually using the bridge inspection truck.
- A catch basin, barrel, or other device will be used to catch any potential bonding agent, patch concrete, or falling debris that could exit the base of the core hole during the patching process.
- A bonding agent will be applied to the core hole walls prior to installation of patch concrete material.
- The core hole will be backfilled with BASF SET 45 chemical action repair mortar, which sets in 15 minutes and has 1 hour and 3 hour strengths of 2000 and 5000 psi respectively. It is rated to receive rolling traffic within 45 minutes. Approximately 3 bags will be used to patch the core hole (Approximately 1 cubic foot required).
- The cover board will be removed after the initial set of the patch concrete and the bridge inspection truck will then permanently demobilize from the site.

Figure 5 (Sheet C-172) presents the bridge restoration plan. As shown on Figure 5 (Sheet C-172), care would be taken to protect the creek bed during the concrete pour through use of cover board below the bridge deck. A catch basin of some type will be positioned directly beneath the core hole location in the bridge deck using the bridge inspection truck boom to contain any potential debris or spillage that might leak out from the core hole patch during repair of the bridge deck. Once the concrete patch has reached adequate strength and final clean-up of the bridge deck work area has been completed, traffic control, the lane closure, and fencing (if still remaining) will be removed. The deck repair work is anticipated to take approximately 1/2 day to complete. The time required to install the patch is conducive to allowing the patch operation to occur on the same day as drill rig demobilization.

2.1.8 Positioning and Survey

The boring location will be initially determined using a hand-held global positioning system (GPS). Upon completion of the drilling and repair of the bridge deck, a survey crew will survey

the location of the boring at the bridge deck and at the ground surface. The approximate position of BH-107 is shown in Figures 6 through 8.

2.1.9 Site Cleanup and Restoration

Once the bridge deck has been patched, the bridge inspection truck will be permanently demobilized. The circular sandbag cofferdam around the boring location will also be removed, and the area restored to its previous condition, taking care to minimize turbidity during removal from the ponded water. Sandbags removed from the cofferdam will be stacked on pallets within the landing zone for hoisting and removal by the crane truck from the bridge deck.

All sandbags and cleanup debris will be hauled up to street level and removed from the site. Temporary traffic control and diversion for the two northern lanes of the bridge will be required while the crane truck is parked on the bridge and is hoisting pallets up from the landing zone during loading. Setup, loading, and breakdown of the crane truck is anticipated to take up to 2 hours.

2.2 PROGRAM SCHEDULE

The estimated start date for field activities is during the summer of 2009. Except for USA clearance marking activities prior to the commencement of the work, the total duration of all work involved is estimated to be approximately 5 working days, with the exploration itself being approximately 2 to 3 days in duration.

It is anticipated that the exploration program will involve one drill rig and up to ten personnel (five crew members, two police officers, one engineer, one biologist, and one traffic control representative) working during the day.

3.0 HEALTH, SAFETY AND ENVIRONMENTAL PLAN

A site-specific Health, Safety and Environmental (HSE) Plan has been developed by the drilling subcontractor to identify hazards, emergency contingency plan, and local emergency contact information (including directions to the nearest hospital).

4.0 TRAFFIC AND PEDESTRIAN CONTROL

Traffic and pedestrian control plans will be developed for the required lane closures. A preliminary traffic control plan is presented in Figure 3 (Sheet C-170), which does not show the additional second lane closure required during crane truck operations. The traffic control plans will be developed and conform to the provisions of Section 12 of the City of San Jose Standard

Specifications, as well as any special conditions required by the City. All work will be planned and conducted with the least possible effects on pedestrian and vehicular traffic. As required by the City, the San Jose Police Department (SJPD) secondary employment unit officers will be scheduled for work within 100 feet of a signalized intersection.

5.0 COMMUNITY OUTREACH

All field personnel will be trained and informed to not answer questions or provide opinions when approached by members of the general public or press who are seeking information regarding the SVRT BART to San Jose Extension Project. Field personnel will be provided with a sufficient number of Fact Sheets describing the project, impacts of the field investigation work being performed, and contact information for additional information. These Fact Sheets will be furnished by the VTA Community Outreach Group. Field personnel will also be provided with Community Outreach business cards, which can be presented by local residents or business owners seeking information related to the investigation. The VTA Community Outreach Group will also be working with the Downtown Business Association and with private property owners.

In addition, the City of San Jose will be updated on a regular basis on the progress and tentative schedule for the exploration program.

July 22, 2009

FIGURES

COYOTE CREEK SOIL INVESTIGATION

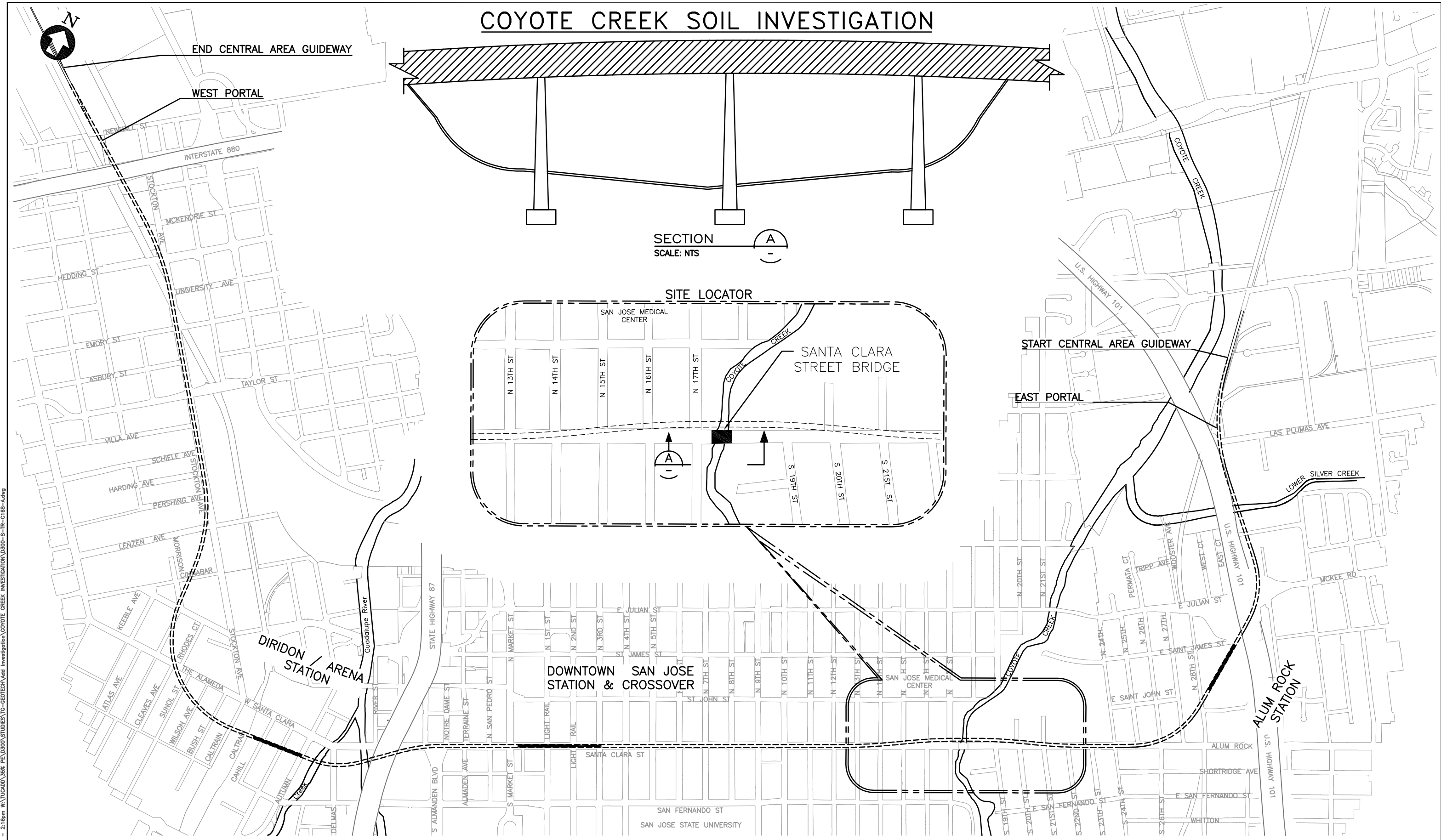

Jun 13, 2008 - 2:16pm W:\TUCAD01\3586_PEL\0300\STUDIES\TG-GEO\TECH\Add_Inv\Investigation\COYOTE_CREEK_INVESTIGATION\0300-S-TR-C168-A.dwg
 JOHNSON_H

REV	DATE	BY	SUB	APP	DESCRIPTION
A					FOR USE

DESIGNED BY
H. JOHNSON
 DRAWN BY
H. JOHNSON
 CHECKED BY
T. HUNT
 IN CHARGE
A. LIU
 DATE

HMM / BECHTEL

A Joint Venture of **Hatch Mott MacDonald T&T, Inc.** and **Bechtel Infrastructure Corp.**



SUBMITTED _____ APPROVED _____

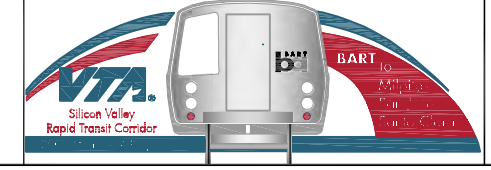

SILICON VALLEY RAPID TRANSIT PROJECT
 CENTRAL AREA GUIDEWAY
 COYOTE CREEK SOIL INVESTIGATION
 LOCATION MAP
 FIGURE 1 OF 8

CADD FILENAME D300-S-TR-C168-A.dwg	
SIZE D	SCALE NTS
CONTRACT NO. D300	REV. A
AREA CODE TR	SHEET NO. C168
PAGE NO.	

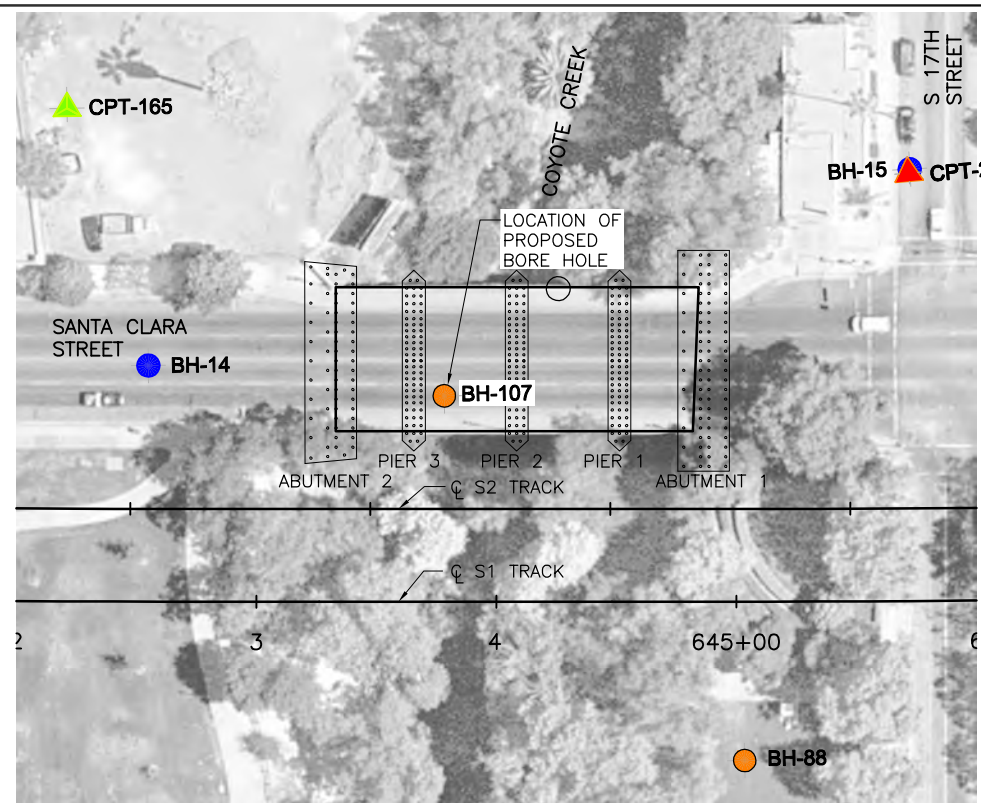

PLAN

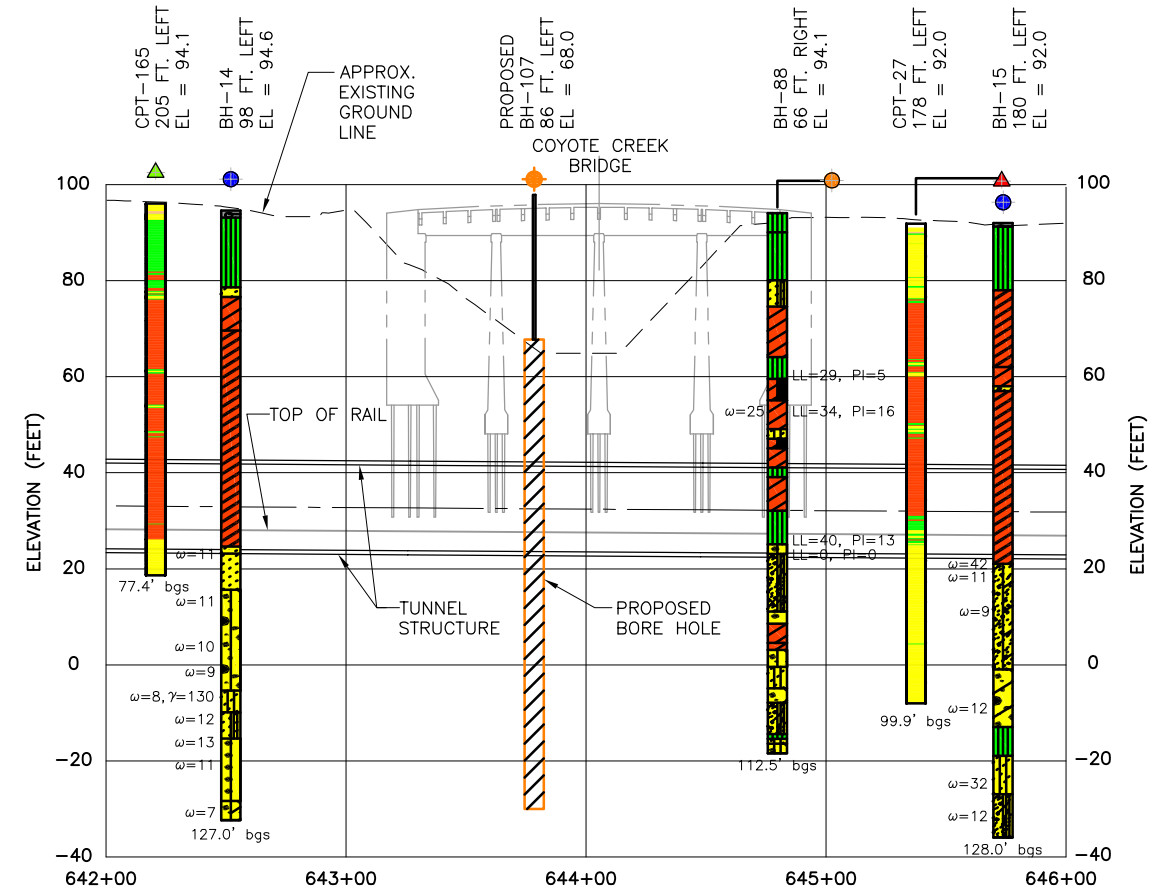

PROFILE



GRAPHIC SCALE



GRAPHIC SCALE

JOHNSON_H Jun 13, 2008 - 2:18pm W:\UCAD01\356 PE\UCAD01\STUDIES\T-G\GEO\TECH\Aid Investigation\COYOTE CREEK INVESTIGATION\0300-S-TR-C169-A.dwg

DESIGNED BY T. HUNT
DRAWN BY H. JOHNSON
CHECKED BY A. LIU
IN CHARGE A. LIU
DATE

REV	DATE	BY	SUB	APP	DESCRIPTION
A					FOR USE

HMM / BECHTEL

A Joint Venture of **Hatch Mott MacDonald T&T, Inc.** and **Bechtel Infrastructure Corp.**

SUBMITTED _____

APPROVED _____



SILICON VALLEY RAPID TRANSIT PROJECT
CENTRAL AREA GUIDEWAY
 COYOTE CREEK SOIL INVESTIGATION
 GEOTECHNICAL PLAN AND PROFILE
 FIGURE 2 OF 8

CADD FILENAME D300-S-TR-C169-A		
SIZE SCALE D 1"=40'H; 1"=20'V		
CONTRACT NO. D300	REV. A	
AREA CODE TR	SHEET NO. C169	PAGE NO.

JOHNSON_H Jun 13, 2008 - 2:19pm W:\TUCAD\356 PE\0300\STUDIES\G-GEOTECH\4d Investigation\COYOTE CREEK INVESTIGATION\0300-S-TR-C170-A.dwg

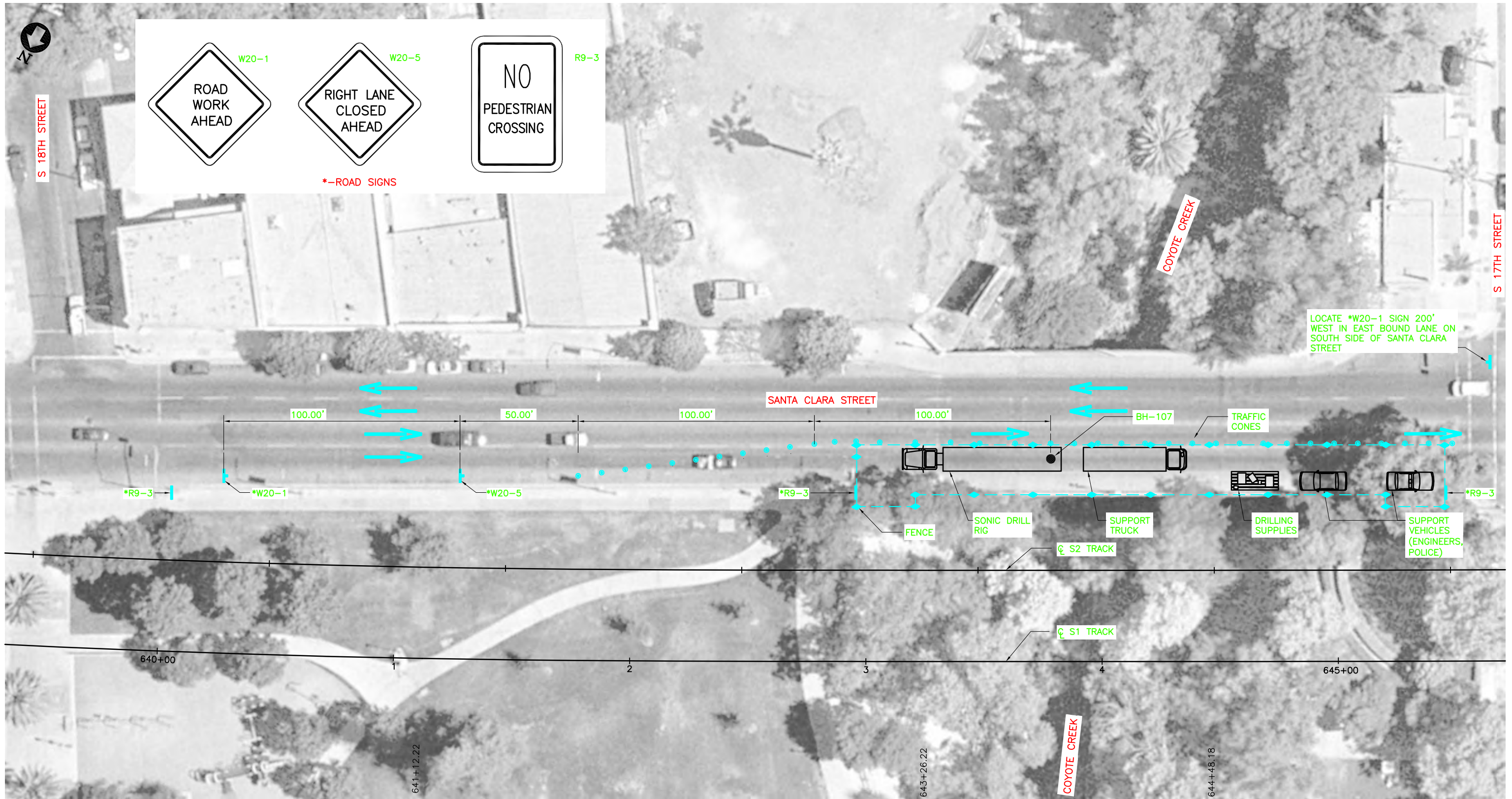

W20-1

W20-5

R9-3

*--ROAD SIGNS

LOCATE *W20-1 SIGN 200' WEST IN EAST BOUND LANE ON SOUTH SIDE OF SANTA CLARA STREET

REV	DATE	BY	SUB	APP	DESCRIPTION
A					FOR USE

DESIGNED BY
T. HUNT
 DRAWN BY
H. JOHNSON
 CHECKED BY
A.LIU
 IN CHARGE
A.LIU
 DATE

HMM / BECHTEL

A Joint Venture of Hatch Mott MacDonald T&T, Inc. and Bechtel Infrastructure Corp.

SUBMITTED _____

APPROVED _____

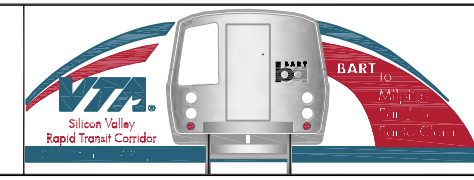

SILICON VALLEY RAPID TRANSIT PROJECT
CENTRAL AREA GUIDEWAY
 COYOTE CREEK SOIL INVESTIGATION
 TRAFFIC CONTROL AND
 WORK SITE STAGING PLAN
 FIGURE 3 OF 8

CADD FILENAME D300-S-TR-C170-A		
SIZE D	SCALE 1"=20'-0"	
CONTRACT NO. D300	REV. A	
AREA CODE TR	SHEET NO. C170	PAGE NO.

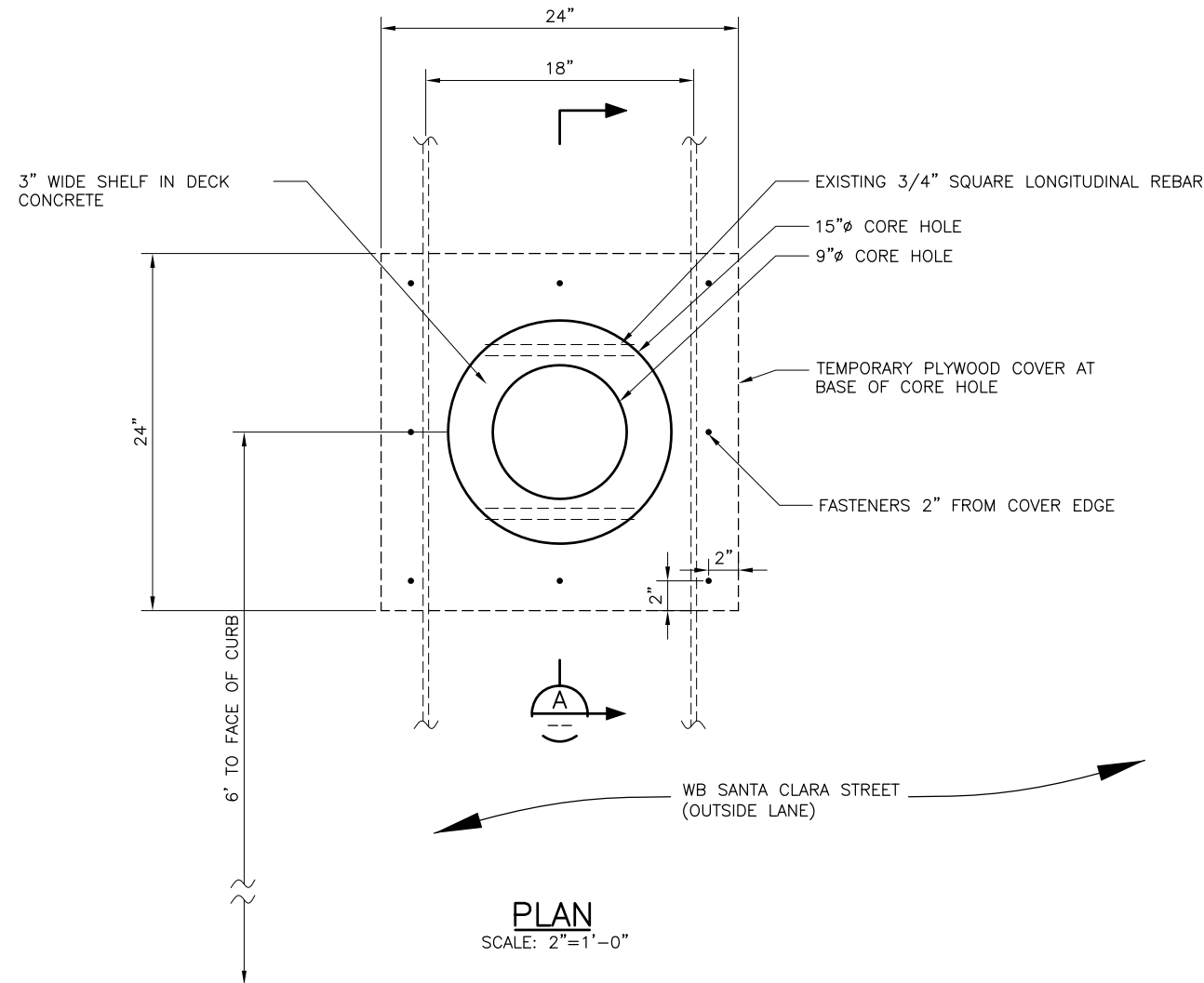

PLAN
SCALE: 2"=1'-0"

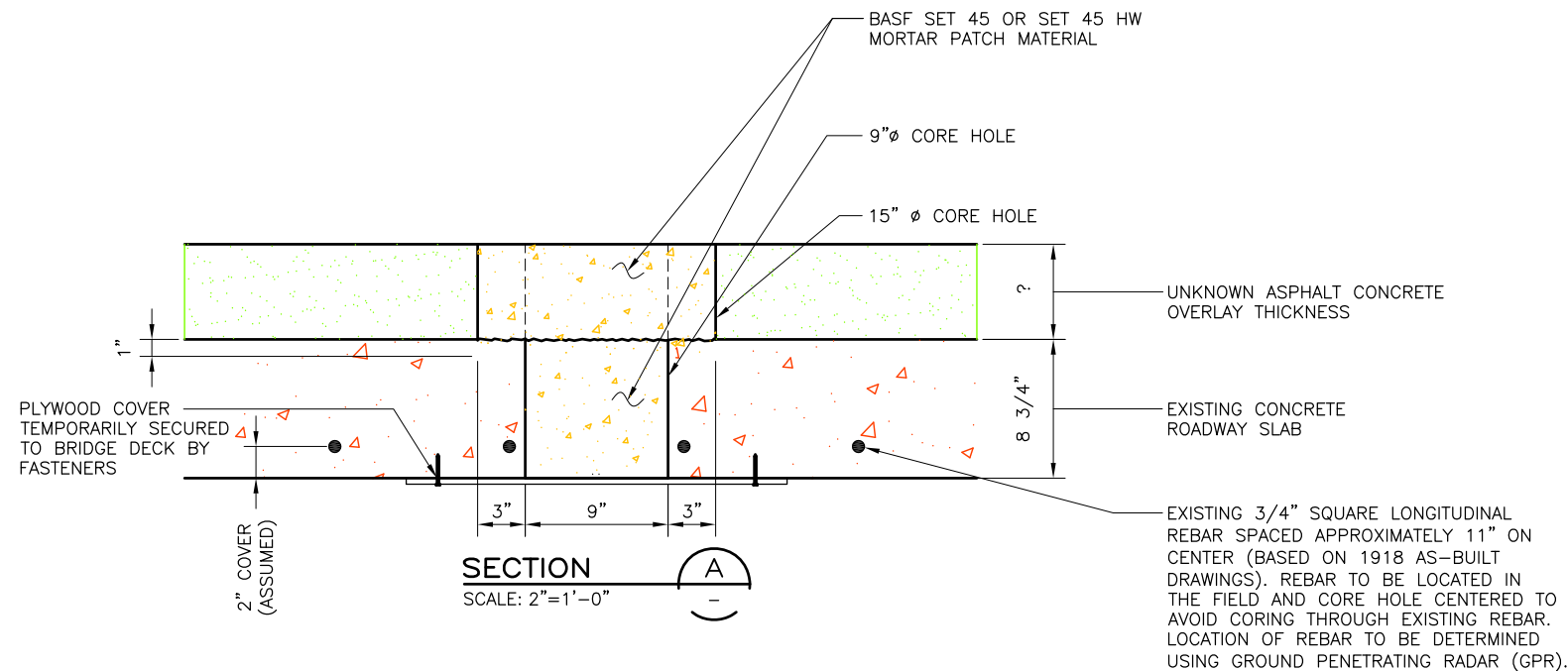

SECTION
SCALE: 2"=1'-0"



GRAPHIC SCALE

NOTES AND SPECIFICATIONS:

1. PATCHING FOR BACKFILL OF CORE DRILLED HOLES TO BASF SET 45 CHEMICAL ACTION MORTAR, ACHIEVING 5000 PSI WITHIN 3 HOURS. SET 45 HW WILL BE REQUIRED IN LIEU OF SET 45 IF AMBIENT TEMPERATURES AT THE TIME THE PATCH IS INSTALLED EXCEED 85 F.
2. 9" DIAMETER CORE DRILLED FOR BOREHOLE.
3. 15" DIAMETER CORE DRILLED FOR TOP HALF OF HOLE
4. NO CONCRETE OR DEBRIS IS ALLOWED TO FALL INTO COYOTE CREEK.

CONSTRUCTION SEQUENCES:

1. DETECT THE LOCATION OF EXISTING EMBEDDED REBAR USING GROUND PENETRATION RADAR (GPR) WITHIN 24" OF THE DEFINED CENTER OF BOREHOLE COORDINATES.
2. MOVE CENTER OF CORE HOLE TO NEW CENTER TO AVOID CORING THROUGH EXISTING REBAR.
3. DRILL 9" DIAMETER CORE HOLE THROUGH ENTIRE THICKNESS.
4. DRILL 15" DIAMETER CORE THROUGH FULL DEPTH OF ASPHALTIC CONCRETE AND TERMINATE AT TOP OF CONCRETE BRIDGE DECK.
5. INSERT 9" NOMINAL STEEL CASING FOR DRILLING, TO BE PERFORMED WITHIN A CLOSED SYSTEM.
6. PERFORM SOIL INVESTIGATION.
7. INSTALL 24"x24" TEMPORARY PLYWOOD COVER AGAINST UNDERSIDE OF BRIDGE DECK AND SECURE WITH FASTENERS.
8. PATCH THE CORED HOLE WITH BASF SET 45 OR SET 45 HW 5000 PSI MORTAR AND REOPEN TO TRAFFIC AFTER 1 HOUR.

WHITE_M Jul 24, 2009 2:15pm C:\PROJ\SCR\0300-S-TR-C172rev1-A.dwg

REV	DATE	BY	SUB	APP	DESCRIPTION
A					FOR USE

DESIGNED BY
T. HUNT
 DRAWN BY
H. JOHNSON
 CHECKED BY
A. LIU
 IN CHARGE
A. LIU

HMM / BECHTEL
 A Joint Venture of Hatch Mott MacDonald T&T, Inc. and Bechtel Infrastructure Corp.

SUBMITTED _____ APPROVED _____



SILICON VALLEY RAPID TRANSIT PROJECT
 CENTRAL AREA GUIDEWAY
 COYOTE CREEK SOIL INVESTIGATION
 BRIDGE CORING AND RESTORATION PLAN
 FIGURE 5 OF 8

CADD FILENAME D300-S-TR-C172-A.dwg		
SIZE	SCALE	
D	2"=1'-0"	
CONTRACT NO.	D300	REV. A
AREA CODE	SHEET NO. TR	PAGE NO. C172

Figure 6 of 8. View looking westbound at Santa Clara Street bridge deck surface.



Approximate location of boring BH-107 at bridge surface.

Figure 7 of 8. View from underside of bridge deck.



Approximate location of the BH-107 core hole at the underside of bridge deck.

Figure 8 of 8. Creek bench surface with ponded water as of May 23, 2008 (near annual peak steam water levels). Work is planned for September 2008, when the benched area below is expected to be relatively dry.



Approximate location of
BH-107 at creek bed.
Area is anticipated to be
dry at time of drilling
(Sept. 2008).

CITY OF SAN JOSE
DEPARTMENT OF PUBLIC WORKS

SANTA CLARA STREET BRIDGE
GIRDER TYPE

LIST OF DRAWINGS

NAME	SHEET NUMBER
PLAN AND ELEVATION	1
FRAMING PLAN	2
BEAMS AND GIRDERS	3
42" GIRDERS	4
PIERS	5
ABUTMENTS	6
HAND RAIL, EXPANSION JOINT AND RETAINING WALL	7

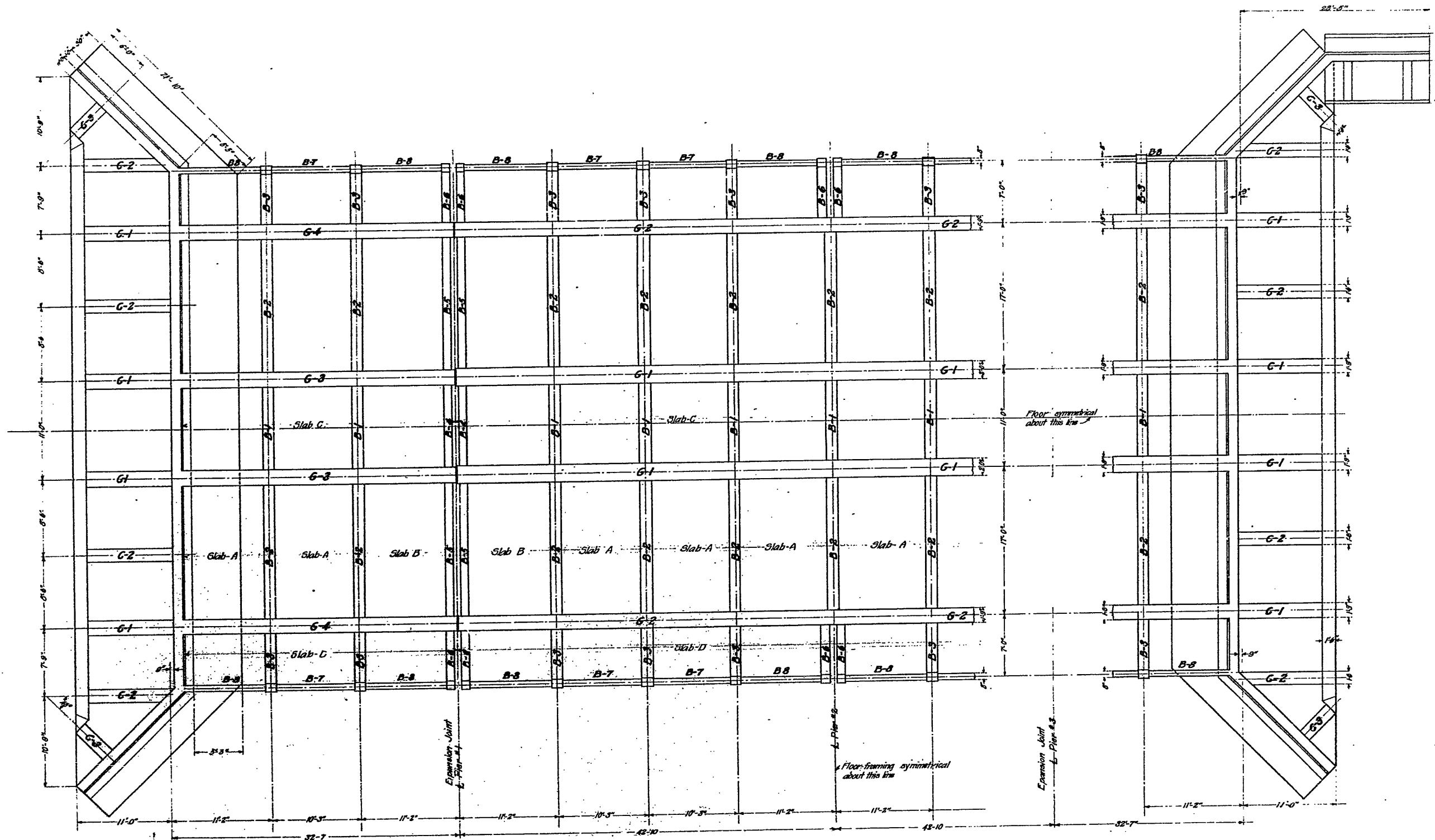

Framing Plan
 Scale: 3/16" = 1'-0"

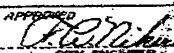
FRAMING PLAN SHEET 2 OF 7 SHEETS	
COYOTE RIVER BRIDGE AT SANTA CLARA STREET	
DEPARTMENT OF PUBLIC WORKS CITY OF SAN JOSE CALIFORNIA	
DRAWN BY: WDL CHECKED BY: CBR SCALE: 3/16" = 1'-0" DATE: MAY 22, 1918	APPROVED  CITY ENGINEER

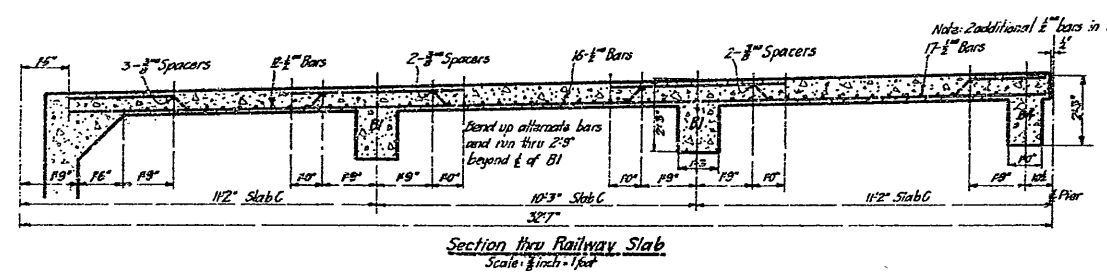
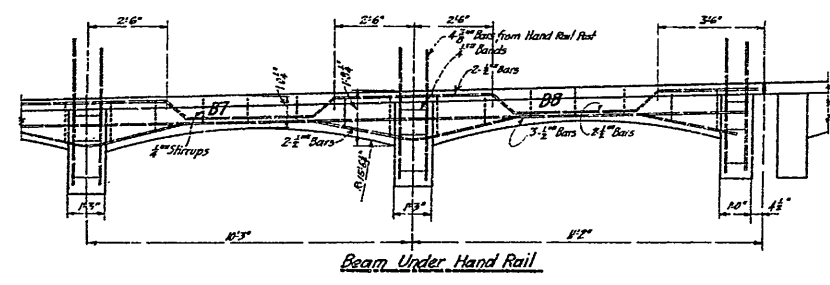
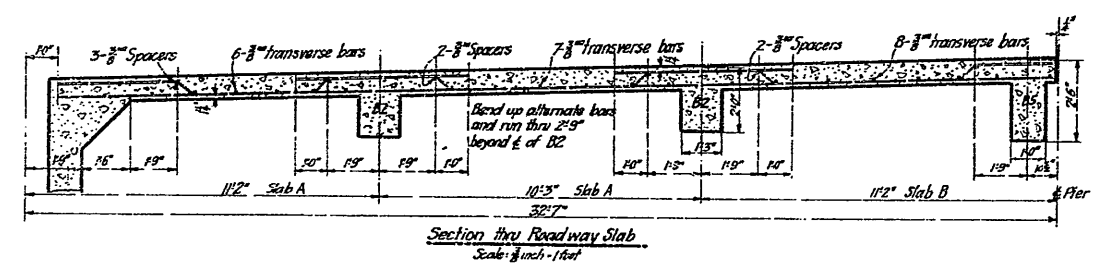
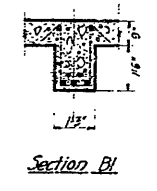
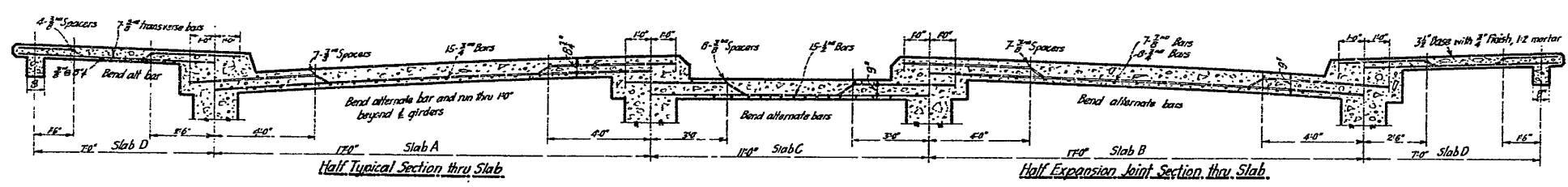
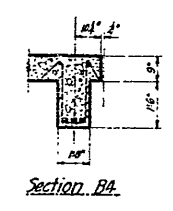
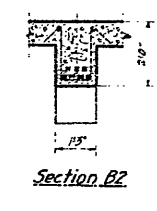
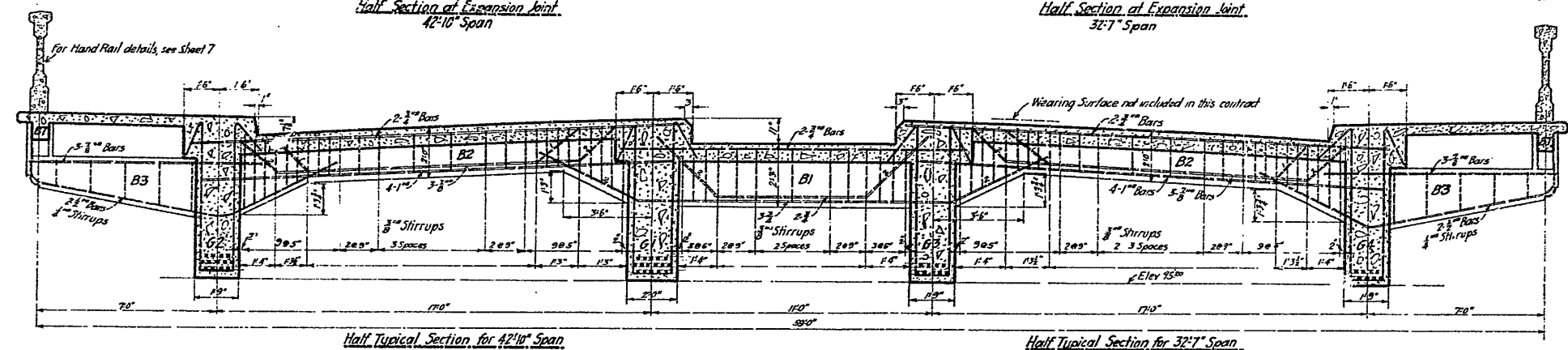
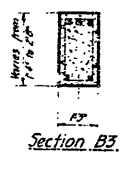
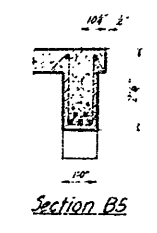
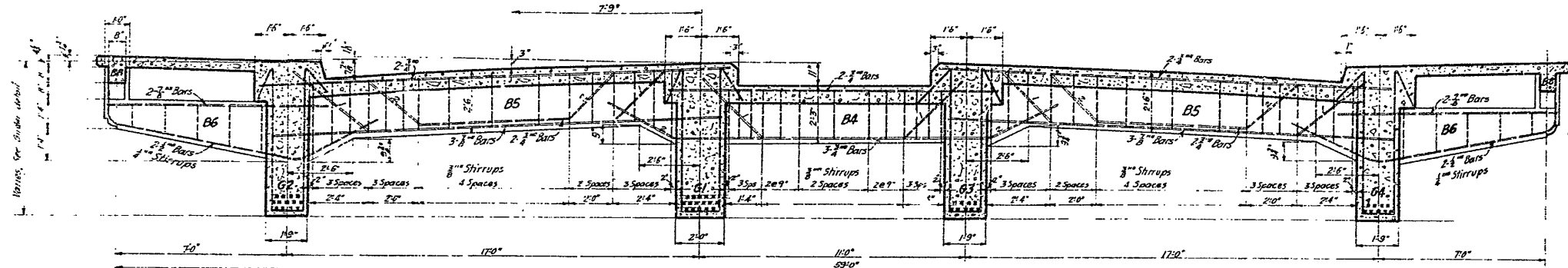
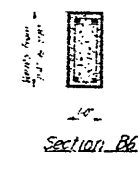

BEAMS AND SLABS
SHEET 3 OF 7 SHEETS
COYOTE RIVER BRIDGE
AT
SANTA CLARA STREET
DEPARTMENT OF PUBLIC WORKS
CITY OF SAN JOSE CALIFORNIA
DRAWN BY: C.B.G.
CHECKED BY: W.D.L.
SCALE: 3/8 INCHES = 1 FOOT
DATE: MAY 22, 1918
APPROVED: *W.D.L.*
CITY ENGINEER

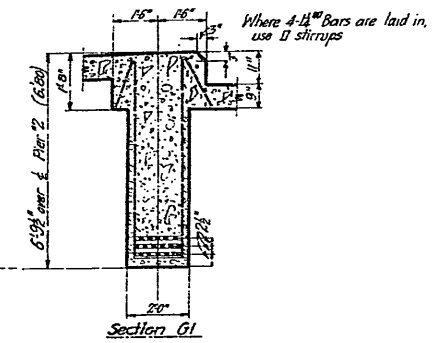
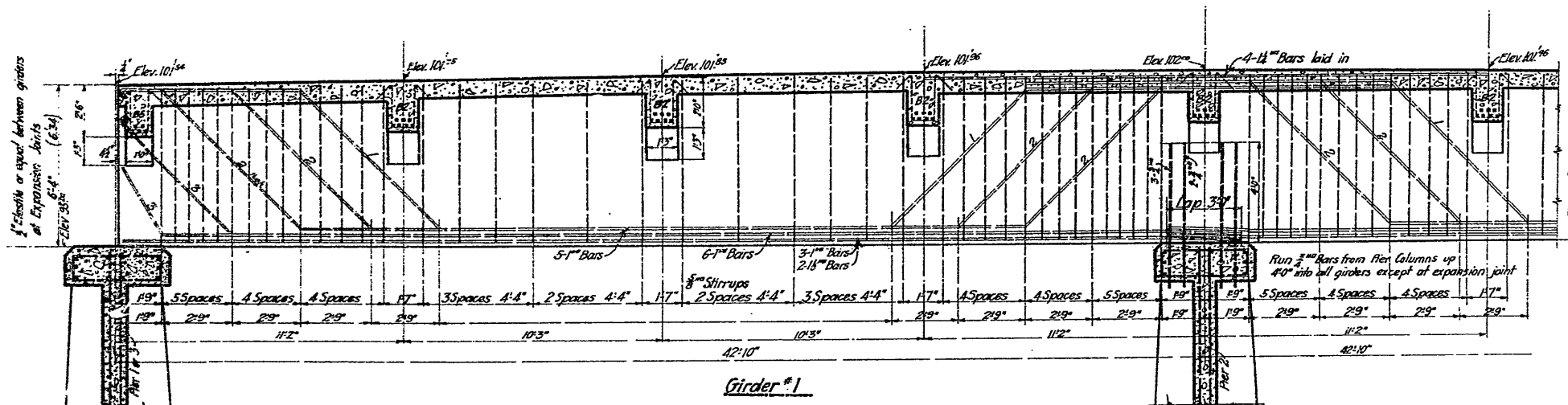
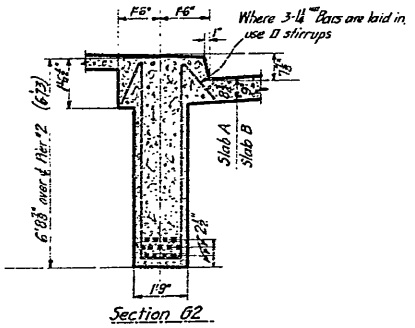
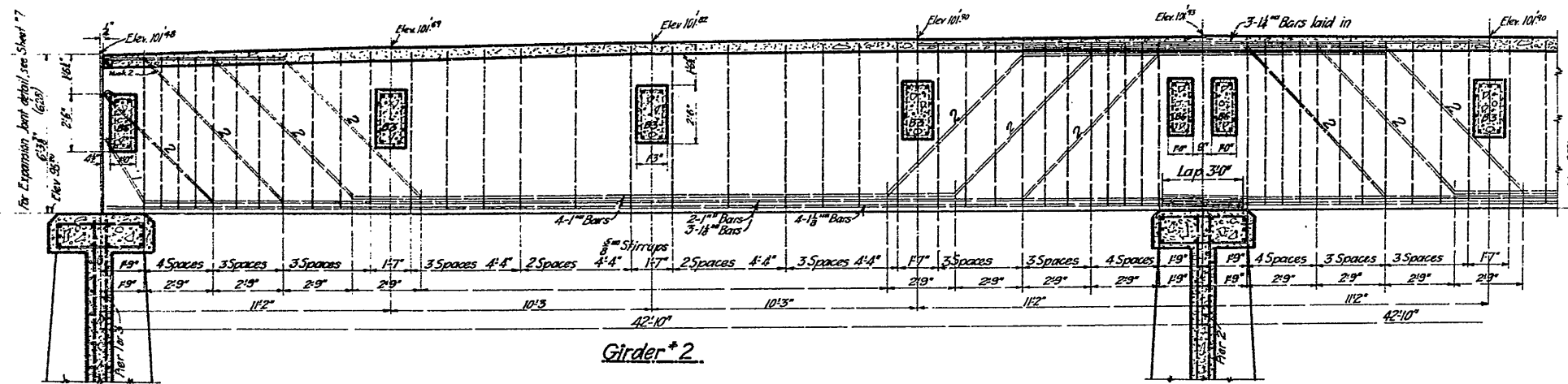
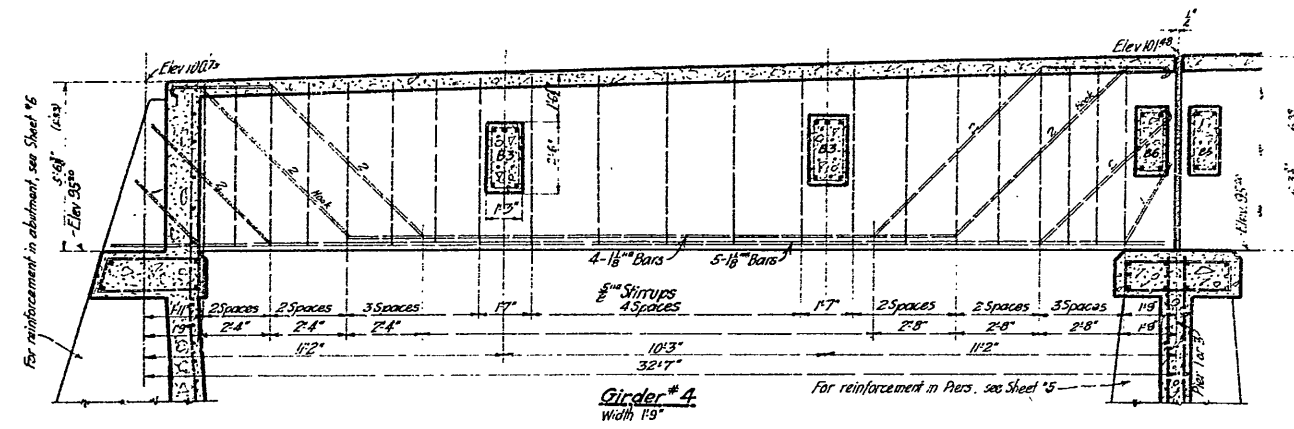
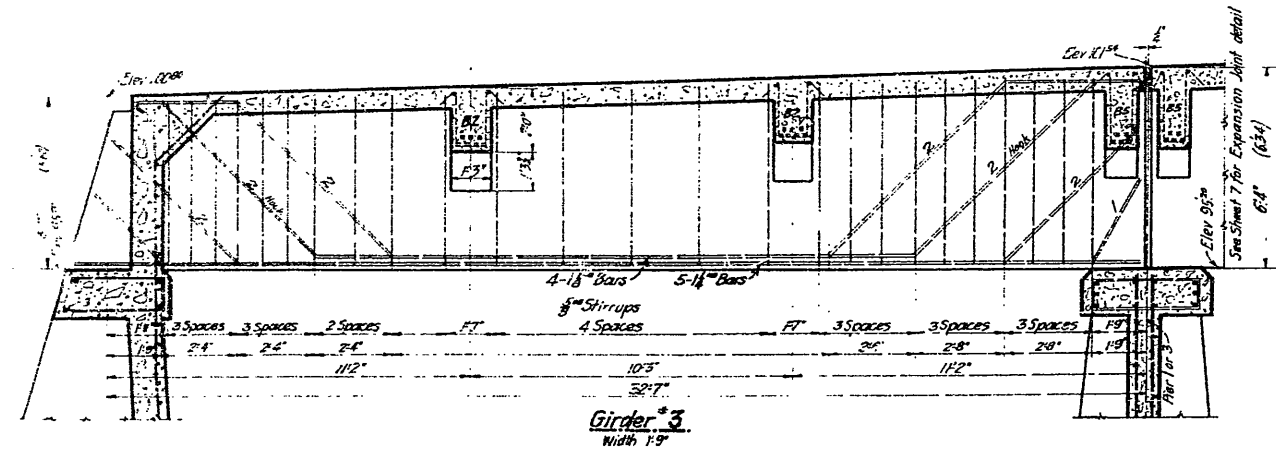

GIRDERS
SHEET 4 OF 7 SHEETS

COYOTE RIVER BRIDGE
AT
SANTA CLARA STREET

DEPARTMENT OF PUBLIC WORKS
CITY OF SAN JOSE, CALIFORNIA.

DRAWN BY C.B.B.
CHECKED BY W.D.L.
SCALE 3/8 INCHES = 1 FOOT
DATE: MAY 22, 1916

APPROVED
R.O. Niblack
CITY ENGINEER

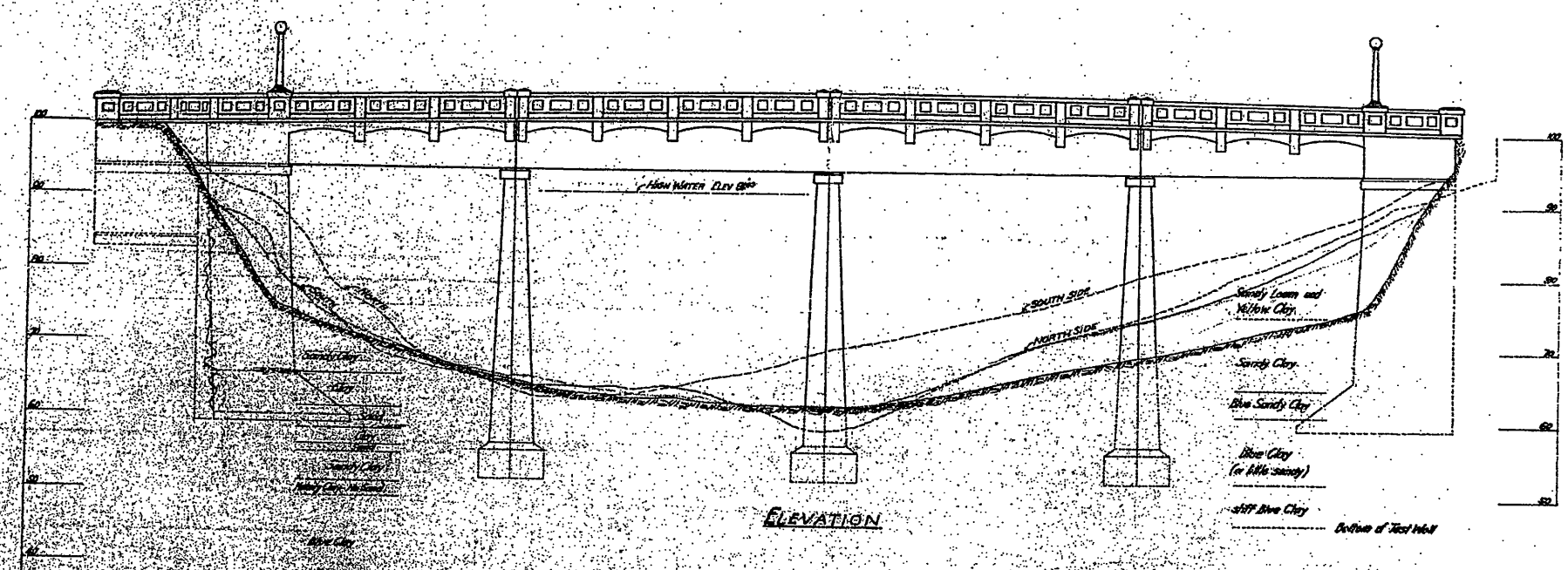
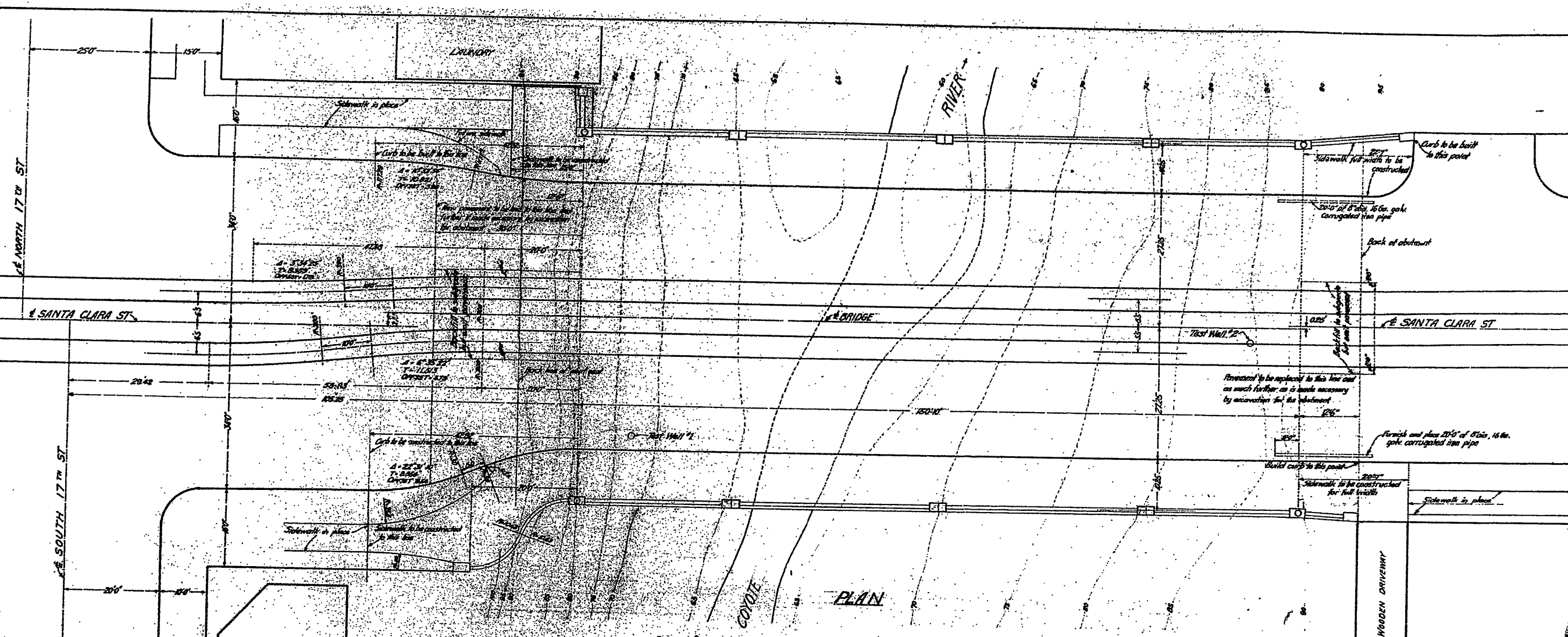

①

SANTA CLARA STREET BRIDGE
OVER THE
COYOTE RIVER
 DEPARTMENT OF PUBLIC WORKS
 CITY OF SAN JOSE, CALIFORNIA

DRAWN BY: CBE
 CHECKED BY: HLL
 DATE: April 1, 1907
 SCALE: 1 inch = 10 feet

APPROVED:

 CITY ENGINEER

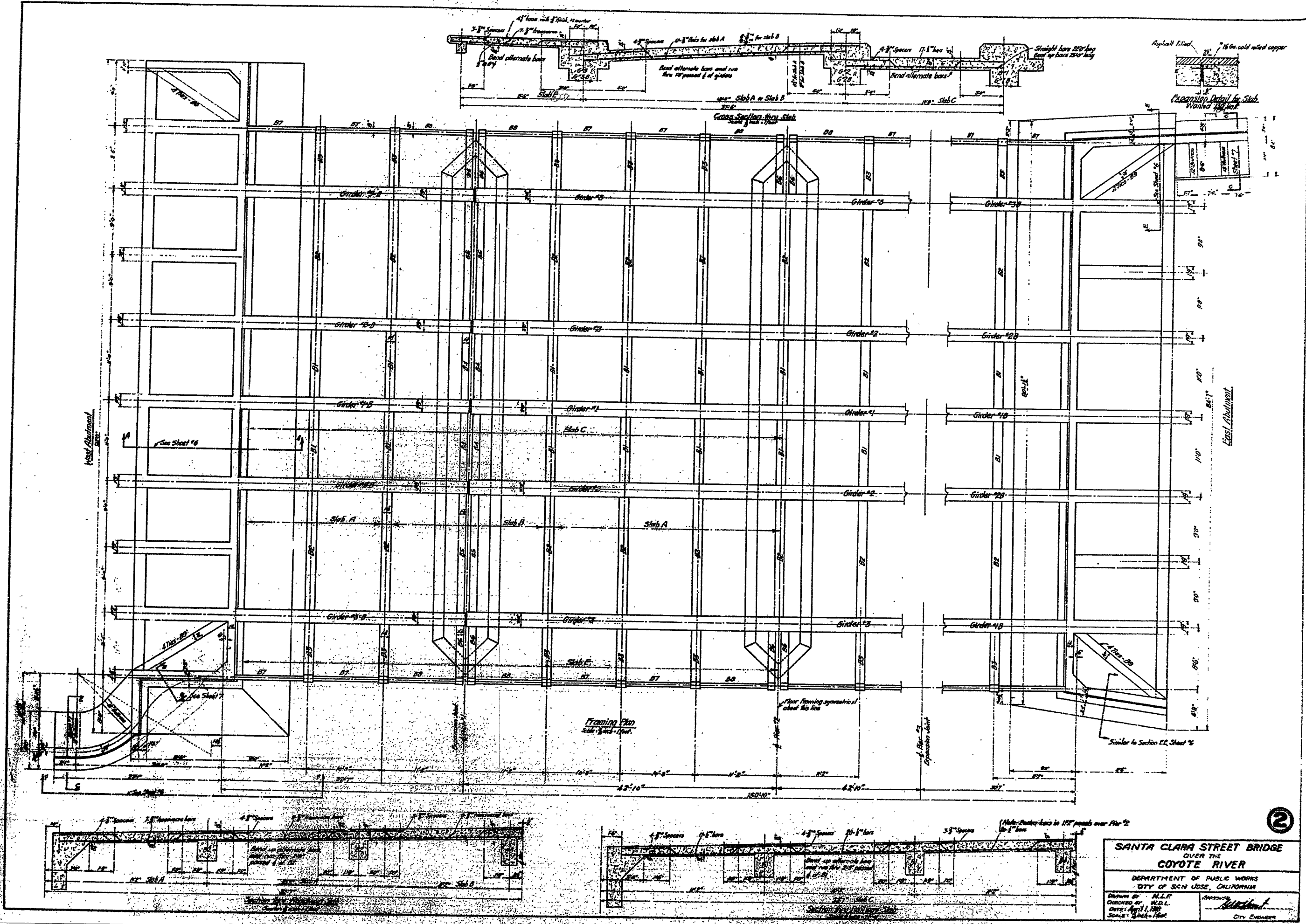

②

SANTA CLARA STREET BRIDGE
OVER THE
COYOTE RIVER

DEPARTMENT OF PUBLIC WORKS
 CITY OF SAN JOSE, CALIFORNIA

Drawn by: M.L.P.
 Checked by: W.D.L.
 Date: April 1, 1920
 Scale: 1/4" = 1'-0"

Approved: *[Signature]*
 City Engineer

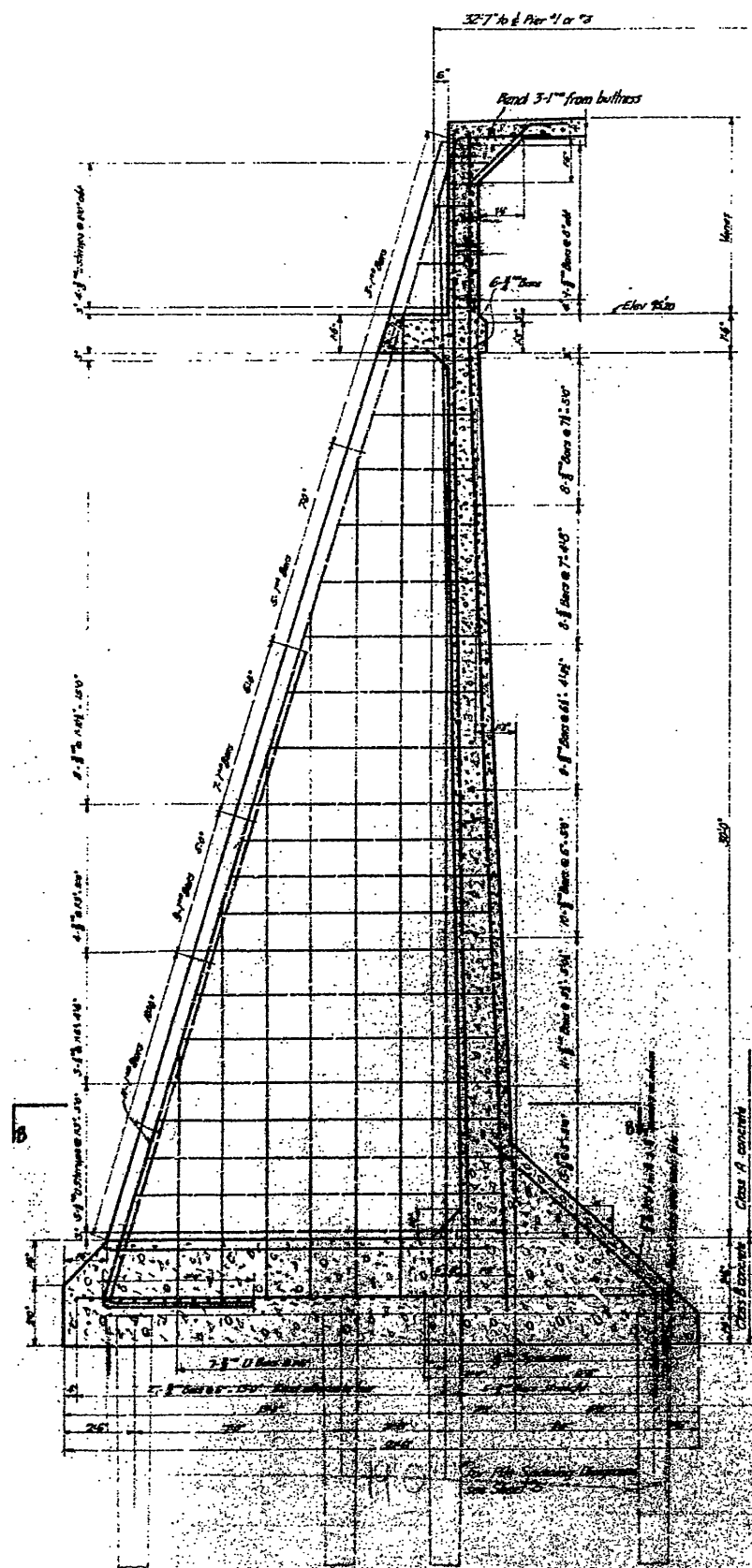

Section AA
Typical Abutment Section
Scale: 1/4\"/>

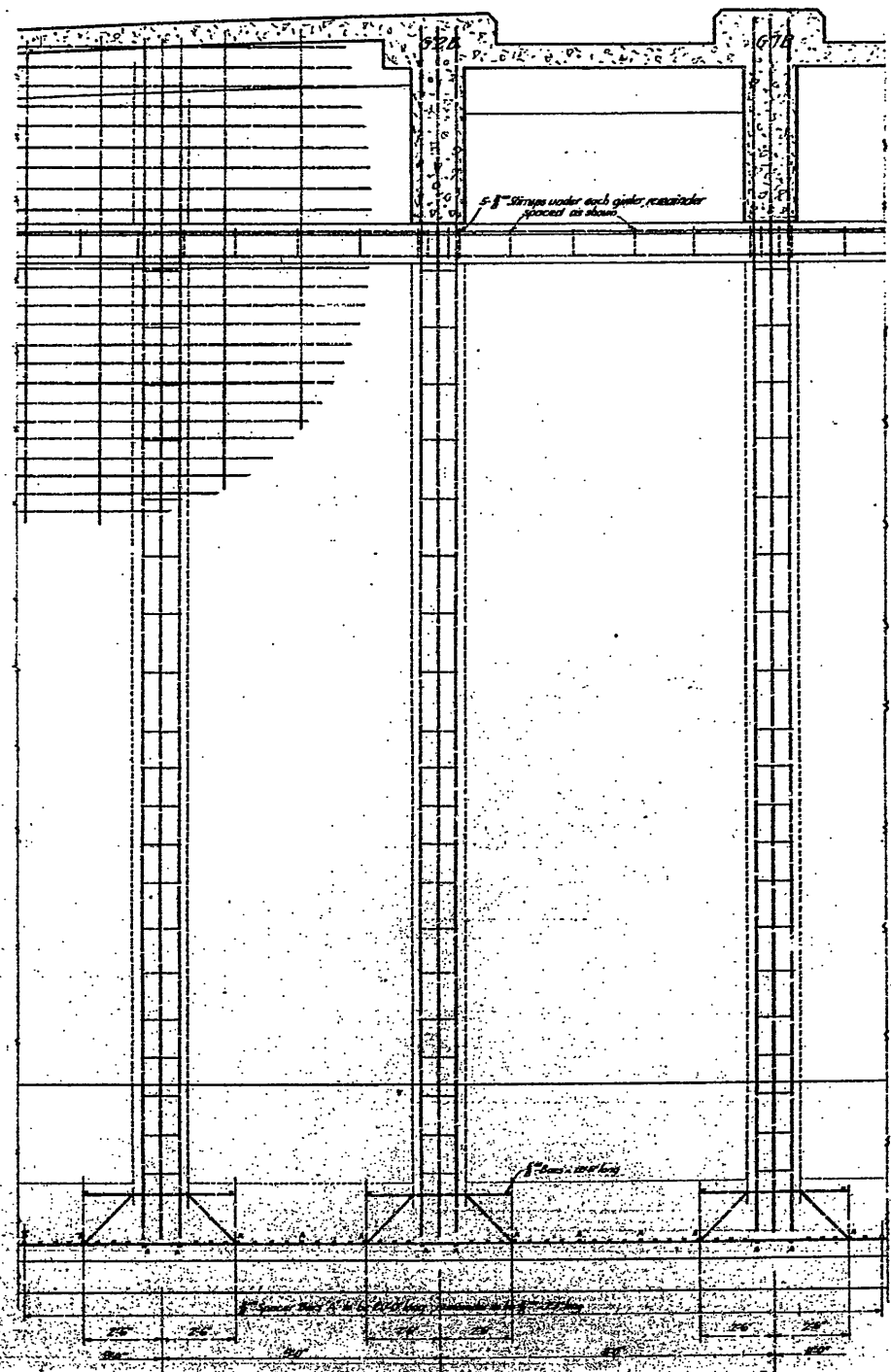

Section BB
Scale: 1/4\"/>

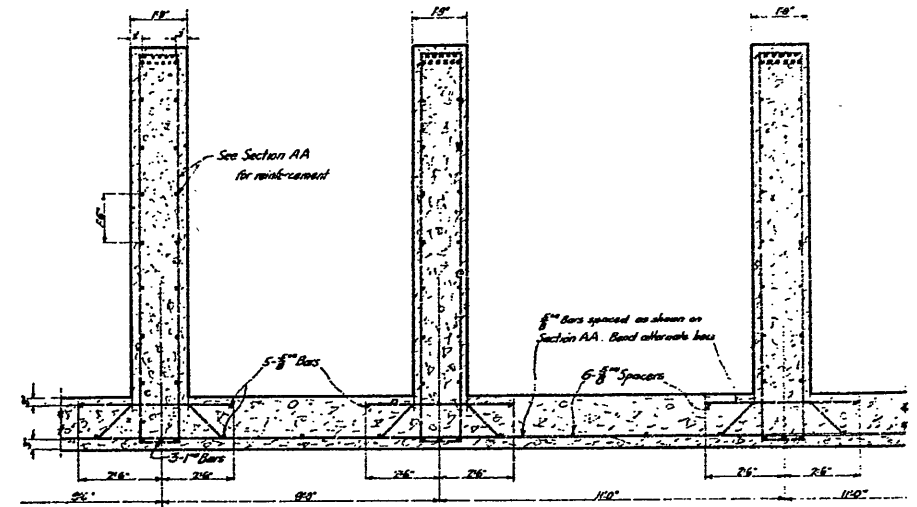

Section BB
Scale: 1/4\"/>

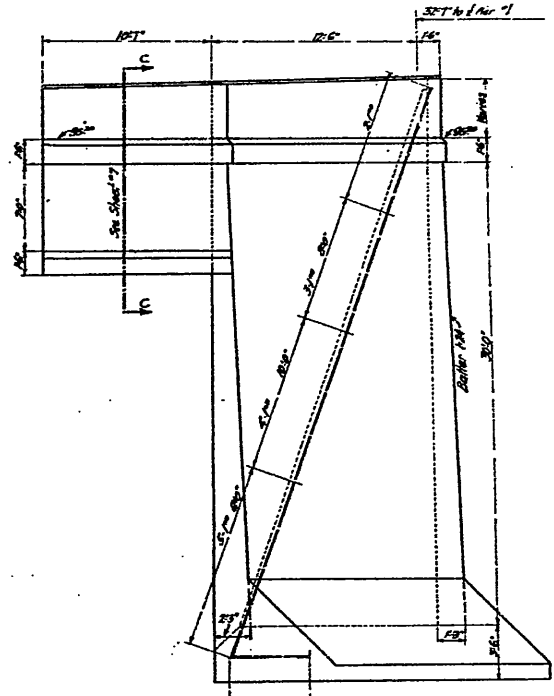

Section FF
Scale: 1/4\"/>

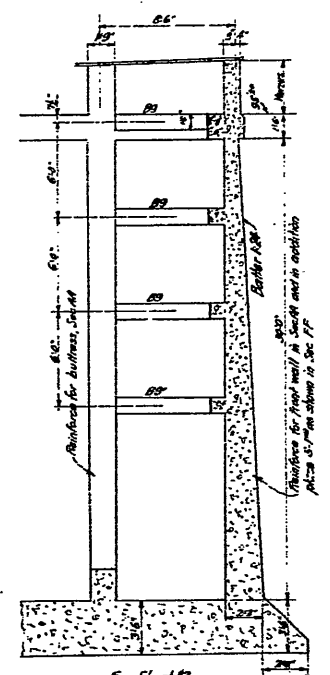

Section EE
Scale: 1/4\"/>

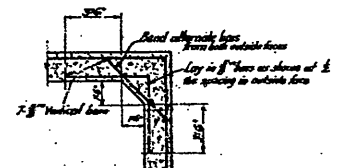

Detail
Scale: 1/4\"/>

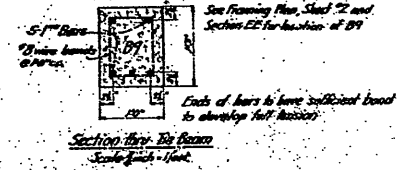

Detail
Scale: 1/4\"/>

6

SANTA CLARA STREET BRIDGE
OVER THE
COYOTE RI'ER
DEPARTMENT OF PUBLIC WORKS
CITY OF SAN JOSE, CALIFORNIA

DRAWN BY: CDB
CHECKED BY: H.D.L.
DATE: APR 1, 1910
SCALE: 1/4\"/>

CITY ENGINEER

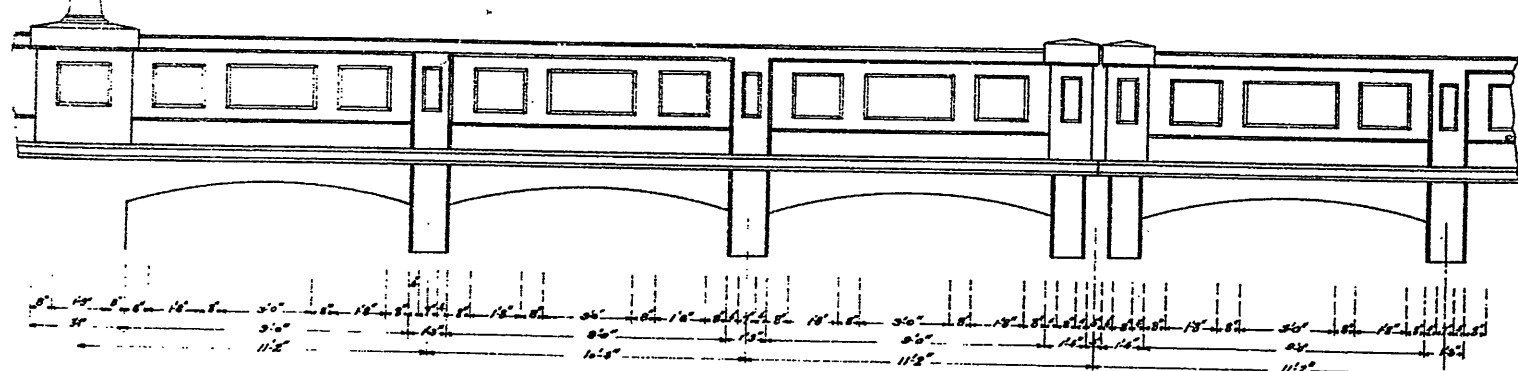

Hand Rail Elevation
Scale 3/4 inch = 1 foot

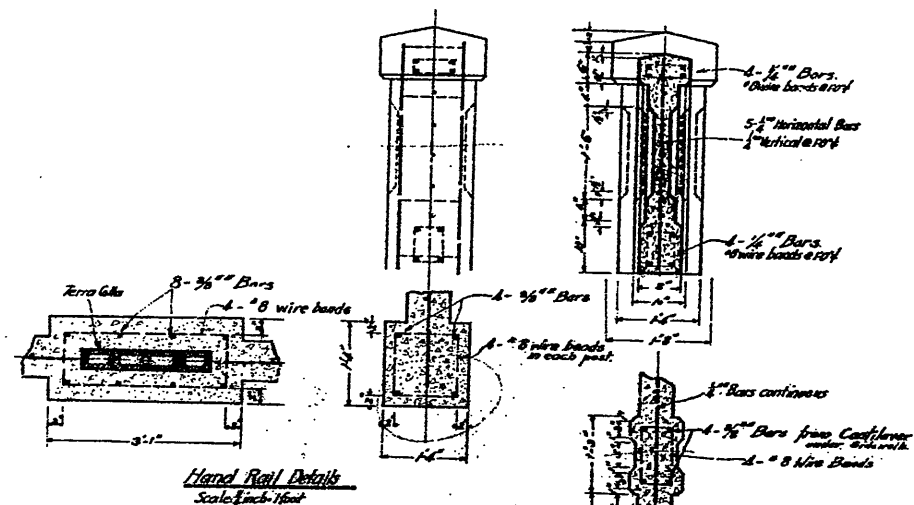

Hand Rail Details
Scale 3/4 inch = 1 foot

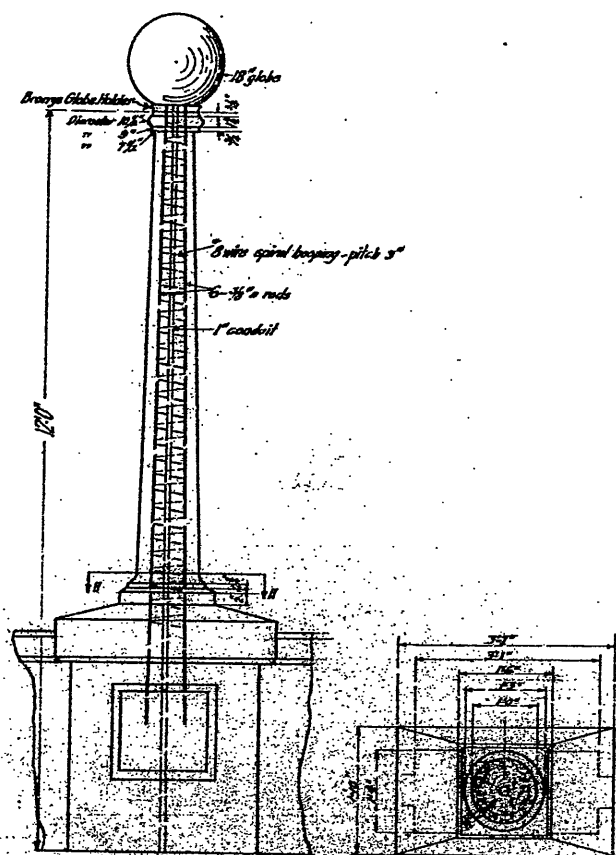

Lamp Post Detail
Scale 3/4 inch = 1 foot

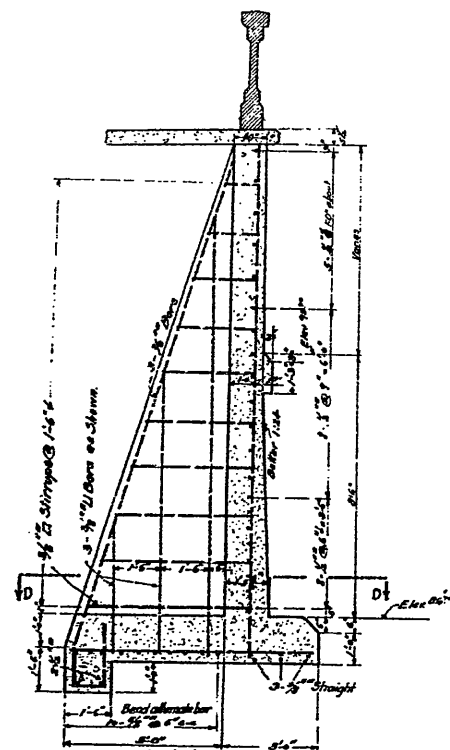

Section CC Retaining Wall
Scale 3/4 inch = 1 foot

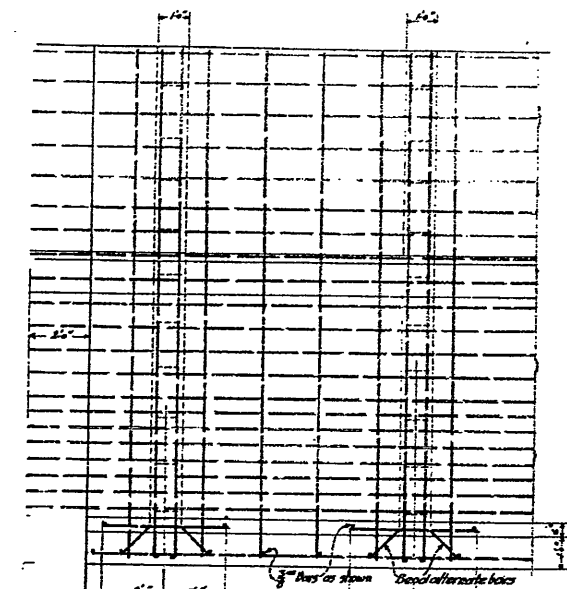

Elevation Retaining Wall

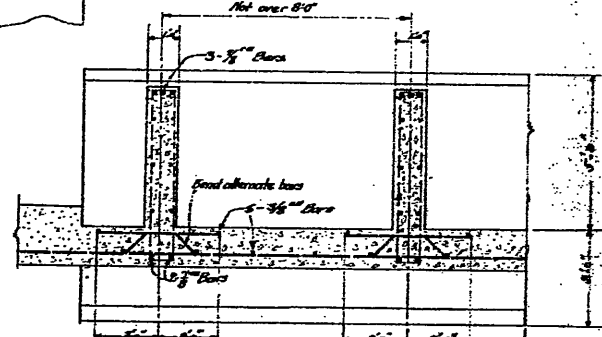

Section DD

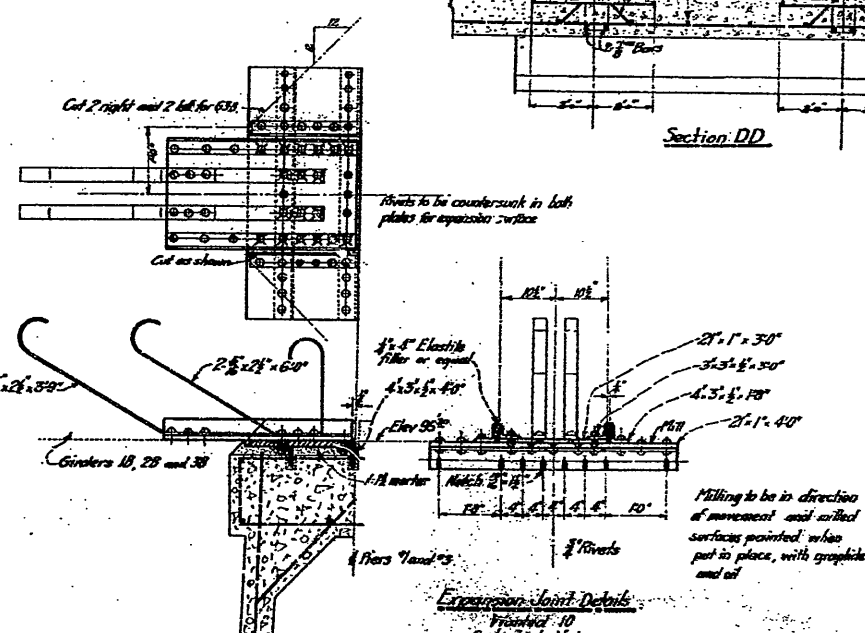

Expansion Joint Details
Scale 3/4 inch = 1 foot

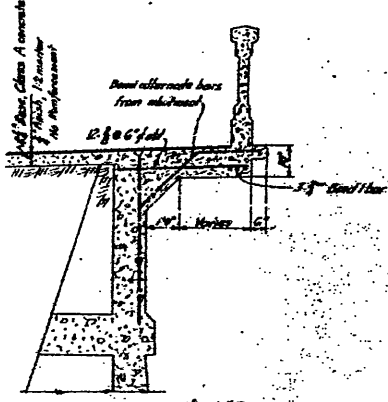

Section GG Sheet 2

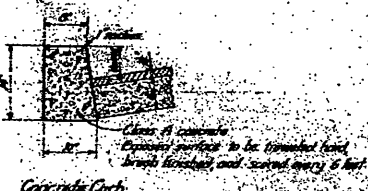

Concrete Curb

SANTA CLARA STREET BRIDGE
OVER THE
COYOTE RIVER

DEPARTMENT OF PUBLIC WORKS
CITY OF SAN JOSE, CALIFORNIA

Drawn by: M.E.P.
Checked by: W.B.L.
Date: April 1935

Approved: *[Signature]*

FROM BOAT LONGYEAR 08-04-2009

KICK-OFF MEETING

3 outriggers

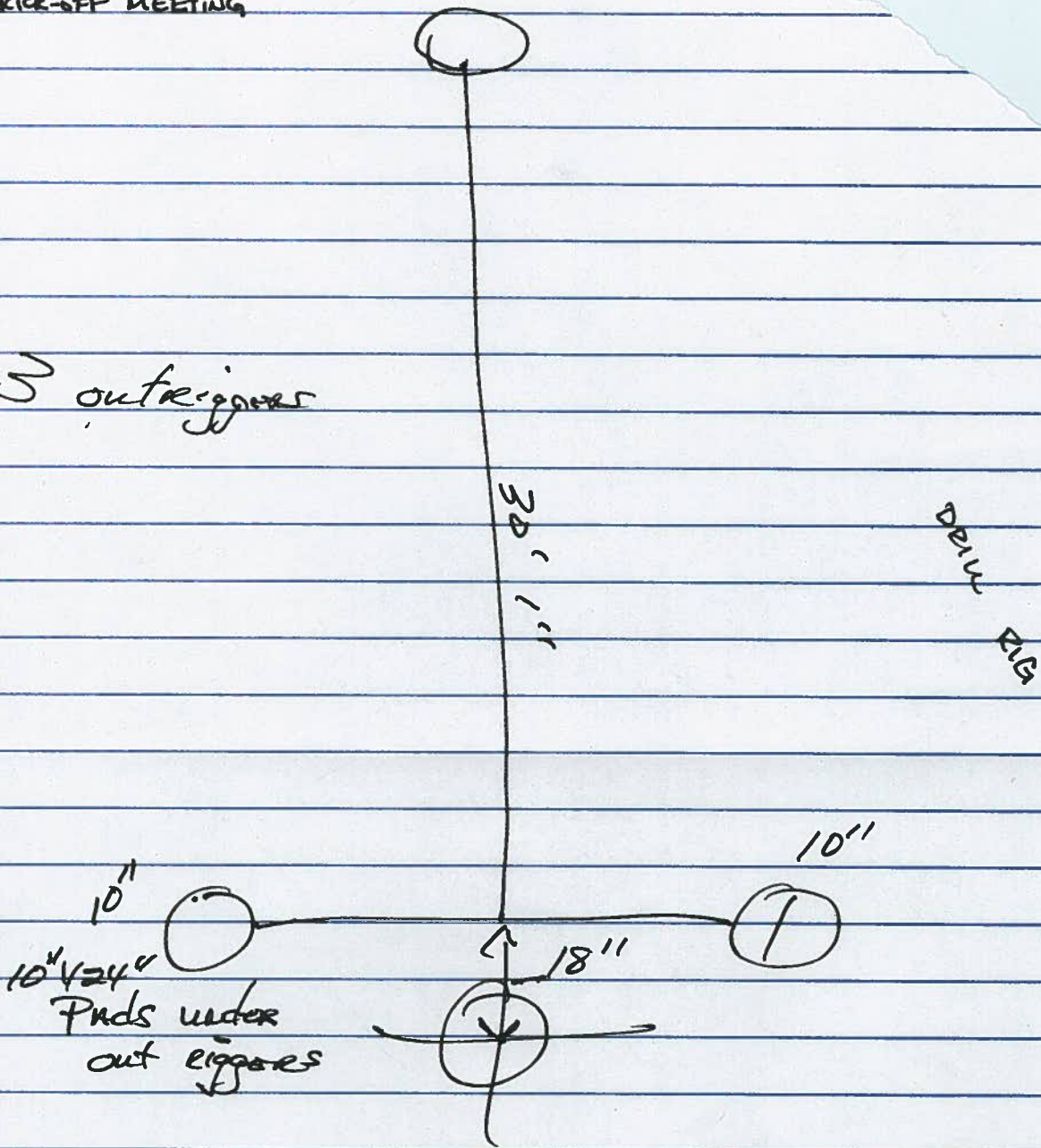

37,000 lbs ±

18,500 lbs. pull back

FROM BOART LONGYEAR 08-04-2009

KICK-OFF MEETING

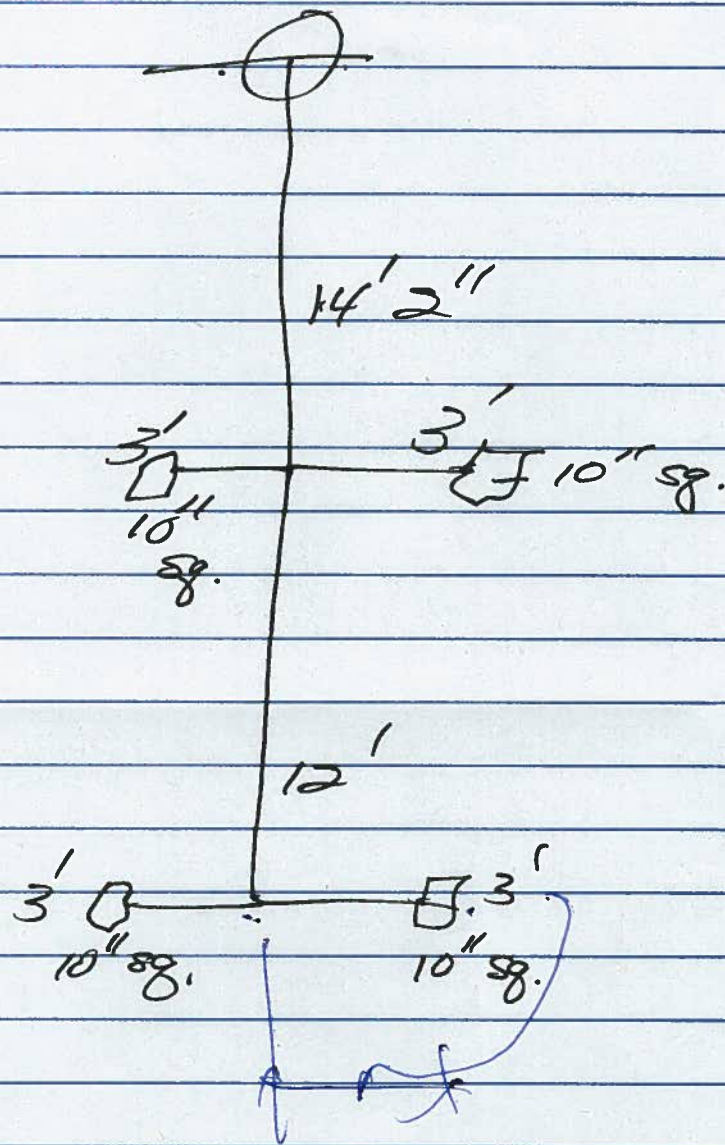

34,000 lbs \pm

FEATURES

- 34,000 lb (13 607 kg) maximum lifting capacity
- 80' (24.38 m) maximum tip height
- 120' (36.57 m) maximum tip height with 24-40' (7.31-12.19 m) jib
- 27-70' (82.30-21.34 m) three-section full power fully synchronized boom
- Exclusive color coded boom and load charts
- Easy-to-install optional 24' (7.31 m) one stage or 24-40' (7.31-12.19 m) two stage telescoping jib, man baskets or work platform increase job capacities
- Electronic Load Moment Indicator and anti-twoblock device standard
- Externally located planetary rotation drive for easy accessibility for maintenance
- 2-speed planetary winch has 9,600 lb (4 350 kg) maximum permissible 1 part line, 33,600 lb (15 240 kg) breaking strength, 186 ft/min (57 m/min) maximum line speed
- Dual control station with direct mechanically controlled hydraulic system
- 70 gal (266 L) capacity hydraulic tank



Machines shown may have optional equipment.

SPECIFICATION

Boom

27-70' (82.30-21.34 m) three-section full power fully synchronized boom. Patented keel boom design utilizes a keel shaped base plate combined with a deep, four plate boom section to optimize strength / rigidity-to-height ratio. Exclusive, patented color-coded boom and load charts allow the operator to easily determine boom extension, boom angle and load capacity. Maximum tip height with three-section 27-70' (82.30-21.34 m) boom is 80' (24.38 m). Maximum tip height with optional two-stage 24-40' (7.31-12.19 m) jib is 120' (36.57 m).

Winch

Hydraulic winch with gear motor and planetary reduction gearing provides 2-speed operation. First layer rope pull of 11,400 lb (5 170 kg). Wire rope size is 9/16" (14 mm) with 33,600 lb (15 240 kg) breaking strength.

Operating Speeds

Mainframe / turret assembly planetary gear rotation provides 180° rotation (370° with optional front bumper outrigger). Swing rotation is 55 seconds. Boom up/down is 25/16 seconds and boom extend/retract is 61/29 seconds.

Hydraulics

Three-section pump allows the operator to perform simultaneous crane operations (winch, boom and swing). Capacities are 32, 17 and 8 gpm (122, 64 and 30 L/m). Hydraulic tank capacity is 70 gpm (266 L/m).

Controls

Fully proportional, excellent metering characteristics for precise boom movements. Independent outrigger controls allow the crane to be stable and level in rigorous working conditions. Load Moment Indication System has audio alarm and functional shut down when operator encounters an overload situation.

Outriggers

Front outriggers are Link-Type. The maximum width over main outrigger pad is 20' 5" (6.23 m), main outrigger spread at maximum ground penetration is 20' (6.10 m).

Rear outriggers are A-Frame. The maximum width over auxiliary outrigger pads is 10' 2" (3.09 m).

Subframe

Single fabricated, closed-box style subframe yields greater strength and rigidity. Wheelbase for standard truck crane mounting configuration is 242" (6.15 m).

OPTIONS AND ACCESSORIES

Terex Stinger offers a wide range of options and accessories to customize your truck crane to your exact needs.

These include:

- Single and two-stage jibs
- Multi-part load blocks
- Plain winch with 2 speed motor
- Auxiliary winch
- Rotation-resistant load line
- Heavy duty wood flatbeds
- Extra heavy duty wood flatbeds
- Extra heavy duty steel flatbeds
- Radio remote controls
- One-man or two-man baskets
- Self-leveling work platform
- Winch drum tensioner
- Continuous rotation
- Oil cooler
- Single front bumper outrigger (required for 370° or continuous rotation)
- Hydraulic hose reel
- Hydraulic auxiliary tool circuit for cab
- Tool Cab

STINGER 3470 LOAD RATINGS

CAUTION: Do not use this specification sheet as a load rating chart. The format of data is not consistent with the machine chart and may be subject to change.

Maximum Load Chart in pounds (lbs) with fully extended outriggers

OPERATING RADIUS (Ft)	BOOM LENGTH												OPERATING RADIUS (Ft)			
	27 Ft		34 Ft		43 Ft		52 Ft		61 Ft		70 Ft					
	LOADED BOOM ANGLE (DEG)	LOAD RATING (LB)	LOADED BOOM ANGLE (DEG)	LOAD RATING (LB)	LOADED BOOM ANGLE (DEG)	LOAD RATING (LB)	LOADED BOOM ANGLE (DEG)	LOAD RATING (LB)	LOADED BOOM ANGLE (DEG)	LOAD RATING (LB)	LOADED BOOM ANGLE (DEG)	LOAD RATING (LB)				
5	77	34,000*											5			
10	66	21,100*	71	17,100*	75	16,000*	78	15,700*					10			
15	54	15,100*	62	14,000*	68	12,100*	72	11,100*	75	10,800*	77	9,600*	15			
20	39	11,100*	51	10,100*	61	9,100*	66	8,600*	71	8,200*	73	7,300*	20			
25	17	7,900*	40	7,700*	53	7,100*	61	6,900*	66	6,600*	69	5,900*	25			
30			23	6,500*	44	6,100*	54	5,600*	60	5,300*	64	4,900*	30			
35					33	4,800*	47	4,700*	54	4,600*	60	4,150*	35			
40	BT & RM Models				16	3,500*	38	4,100*	48	3,900*	55	3,550*	40			
45										27	3,250*	41	3,200*	49	3,050*	45
50	NOTE: STRUCTURAL STRENGTH RATINGS IN CHART ARE INDICATED WITH AN ASTERISK (*)						9	2,950*	33	2,800*	44	2,650*	50			
55												23	2,500*	37	2,350*	55
60														29	1,900*	60
65											19	1,700*	65			

Area of Operation BT & RM

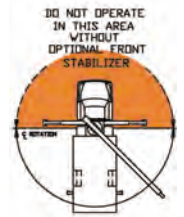

Deductions from rated loads for load handling devices BT & RM

- Overhaul**
- Ball: 125 lbs
 - 1 Tip Load Block: 200 lbs
 - 2 Tip Load Block: 230 lbs
 - Aux Tip: 50 lbs

Stowed Jib Deductions (Pounds)

450	360	260	230	200	175
-----	-----	-----	-----	-----	-----

JIB CAPACITIES FOR ALL BOOM LENGTHS

VERIFY OPERATIONAL MODE SETTING ON LMI DISPLAY BEFORE LIFTING WITH JIB

Loaded Boom Angle	35°	40°	45°	50°	55°	60°	65°	70°	75°	80°
Retracted 24 ft. Jib	700	825	1,000	1,150	1,340	1,600	1,900	2,300	3,100	4,160
Extended 40 ft. Jib	520	580	650	730	810	930	1,080	1,400	1,810	2,260

General Notes

- The operator must read and understand the Owner's Manual before operating this crane.
- Positioning or operation of crane beyond areas shown on this chart is not intended or approved except where specified in Owner's Manual.
- Loaded boom angles at specified boom lengths give only an approximation of the operating radius. The boom angle before loading should be greater to account for deflections. Do not exceed the operating radius for rated loads.
- Use rating of next longer boom for boom lengths not shown. Use rating of next greater radius for load radii not shown.
- Boom must be fully retracted when jib is erected before lowering below minimum angle. Retracted jib has no lifting capacity below a 50° boom angle.
- Use rating of next lower boom angle for boom angles not shown on jib load rating chart.
- Lifting off the main boom point while the swing around jib is erected is not intended or approved.
- Do not lower boom into this area, as hydraulic pressure will not allow raising the boom without retracting boom first.
- Crane load ratings on outriggers are based on freely suspended loads with the machine leveled and standing on a firm uniform supporting surface. No attempt shall be made to move a load horizontally on the ground in any direction.
- Practical working loads depend on supporting surface, wind and other factors affecting stability such as hazardous surroundings, experience of personnel, and proper handling, must all be taken into account by the operator.
- The maximum load which may be telescoped

is limited by hydraulic pressure, boom angle, and boom lubrication. It is safe to attempt to telescope any load within the limits of the load rating chart.

INFORMATION

- Deductions must be made from rated loads for stowed jib, optional attachments, hooks and loadblocks (see deduction chart). Weights of slings and other load handling devices shall be considered a part of the load.
- Crane load ratings with outriggers are based on outriggers and stabilizers extended and set with all load removed from the carrier wheels.
- Load ratings do not exceed 85% of tipping load.

DEFINITIONS

- Operating radius is the horizontal distance from the axis of rotation to the center of the vertical hoist line or load hook with load suspended.
- Loaded boom angle as shown in the Load Ratings Chart is the included angle between the horizontal and longitudinal axes of the boom base after lifting rated load at rated radius.

Range Diagram (27 – 70 Ft boom)

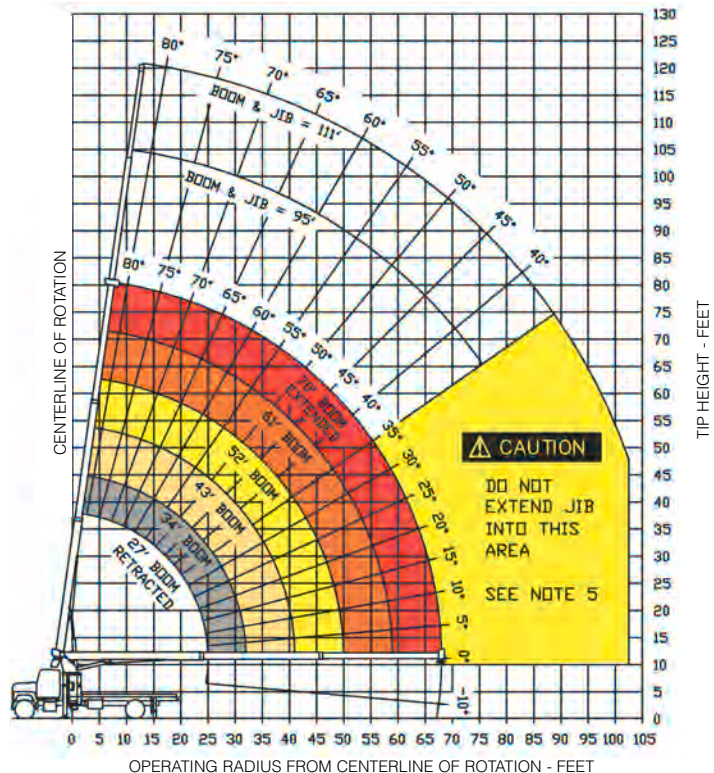

WINCH DATA

		1 Part Line	2 Part Line	3 Part Line	4 Part Line
Winch	Cable Supplied	Lift and Speed	Lift and Speed	Lift and Speed	Lift and Speed
Standard Stationary Winch	9/16" Diam. IWRC XIP	9,600 lb. 186 fpm*	19,200 lb. 93 fpm*	28,800 lb. 62 fpm*	34,000 lb. 45.5 fpm*
	9/16" Diam. Rotation Resistant	6,720 lb. 186 fpm*	13,440 lb. 93 fpm*	20,160 lb. 62 fpm*	26,880 lb. 45.5 fpm*

Block Type	Rating
Overhaul Ball	6.5 ton (5.9 mt)
1 Sheave Block	17 ton (15.4 mt)

CAUTION

Overload and anti-two-block systems must be in good operating condition before operating crane. Refer to Owners Manual. Keep at least 3 wraps of loadline on drum at all times. Use only 9/16" diameter cable with 33,600 lb. breaking strength on this machine.

2 DIFFERENT MOUNTING CONFIGURATIONS

• Behind Cab Mounting Configuration

DIMENSIONAL DATA

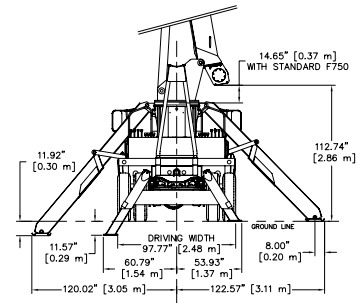
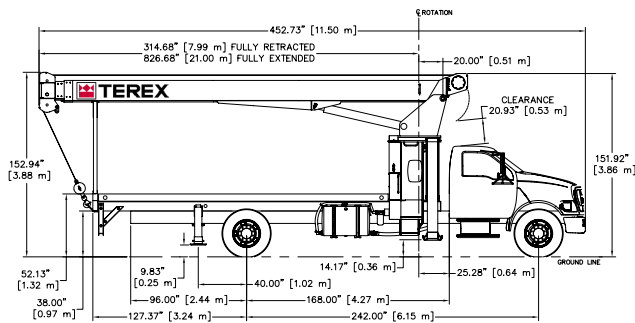

CARRIER PROVIDED BY TEREX

STINGER BT3470 - Behind Cab Mounting Configuration

Manufacturer	2005 Ford F-750 4 x 2 Chassis
Standard Engine	Caterpillar C-7 7.2 L I-6
Standard Horsepower	210 hp @ 2,500 rpm
Standard Torque	605 lb. Ft. @ 1,440 rpm
Full Tank Capacity	45 gal (170 L)

• Standard Transmission	Spicer ES066-7B
Speed Standard Transmission	Manual 7-speed
Max Speed Standard Transmission	74 mph (118.4 km/h)
Max Gradeability Standard Transmission	17.7% in 1st 15.8% in Rev

• Optional Transmission	Allison
Speed Optional Transmission	Automatic 5-speed
Max Speed Optional Transmission	74 mph (118.4 km/h)
Max Gradeability Optional Transmission	21.1% in 1st 30.5% in Rev

Gross Vehicle Weight Rating	33,000 lb (14 969 kg)
Front Axle Weight Rating	12,000 lb (5 443 kg)
Rear Axle Weight Rating	21,000 lb (9 525 kg)
Front Tires	22.5" x 8.5" 11R22.5 G Goodyear G159
Rear Tires	22.5" x 7.5" 11R22.5 G Goodyear G167A
Brakes	Air, Hydraulic Anti-Lock System
Exhaust Position	Horizontal Left Side

Included Options:

Fuel tank (45 gal)-175 L
Power steering
Electric Horn
Factory A/C
Power Port (Cigar lighter)
AM/FM Radio w/ Clock
Dual West Coast Stainless
Standard Factory Warranty

CHASSIS RECOMMENDATIONS-MINIMUM REQUIREMENT

STINGER BT3470 - Behind Cab Mounting Configuration

Combined Axle Weight Rating	33,000 lb (14 969 kg)
Front Axle Weight Rating	12,000 lb (5 443 kg)
Rear Axle Weight Rating	21,000 lb (9 525 kg)
Wheel base	242" (6.15 m)
Cab to Axle	168" (4.27 m)
Afterframe	96" (2.44 m)
Frame Section Modulus	16.98 in ³ (278 cm ³)
RBM per Frame Rail	1,400,000 in/lb (16 130 kg/m)
Frame Height (Unloaded)	40" (7.62 m)
Exhaust Position	Horizontal Left Side

STINGER™ 3470

Boom Truck Crane

2 DIFFERENT MOUNTING CONFIGURATIONS

• Rear Mount Configuration

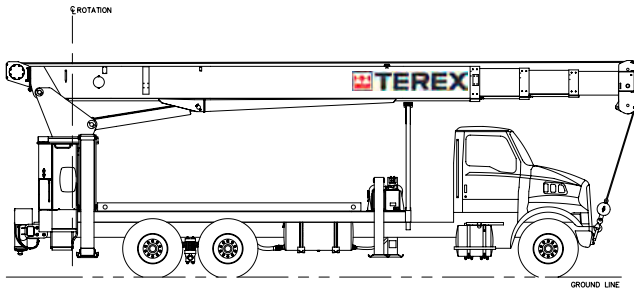

CARRIER PROVIDED BY TEREX

STINGER RM3470 – Rear Mount Configuration

Manufacturer	2004 Sterling LT7501 6 x 4 (60 000)
Standard Engine	Caterpillar C-7 7.2 L I-6
Standard Horsepower	300 hp @ 1,440 rpm
Standard Torque	860 lb. Ft. @ 1,500 rpm
Full Tank Capacity	60 gal (227 L)

• Standard Transmission	Eaton Fuller RT-8908LL
Speed Standard Transmission	Manual 10-speed
Max Speed Standard Transmission	74 mph (120 km/h)
Max Gradeability Standard Transmission	54%

• Optional Transmission	Allison
Speed Optional Transmission	Automatic 6 speeds
Max Speed Optional Transmission	74 mph (120 km/h)
Max Gradeability Optional Transmission	17%

Gross Vehicle Weight (without crane)	60,000 lb (27 210 kg)
Front Axle Weight Rating (without crane)	20,000lb (9 067kg)
Rear Axle Weight Rating (without crane)	40,000 lb (18 144 kg)
Front Tires	425/65R 22.5 Michelin XZY (20 ply)
Rear Tires	11R 22.5 Michelin XDE M/S (14 ply)
Brakes	Air, Hydraulic Anti-Lock System
Exhaust Position	Horizontal Left Side

Included Options:

Fuel tank (45 gal-175 L)
Power steering
Electric Horn
Factory A/C
Power Port (Cigar lighter)
AM/FM Radio w/ Clock
Dual West Coast Stainless
Standard Factory Warranty

CHASSIS RECOMMENDATIONS-MINIMUM REQUIREMENT

STINGER RM3470 – Rear Mount Configuration

Combined Axle Weight Rating	60,000 lb (27 210 kg)
Front Axle Weight Rating	20,000 lb (9 067 kg)
Rear Axle Weight Rating	40,000 lb (18 144 kg)
Wheel base	261" (6.62 m)
Cab to Axle	192" (4.87 m)
Afterframe	114" (2.89 m)
Frame Section Modulus	30.00 in ³ (4.91 cm ³)
RBM per Frame Rail	1,800,000 in/lb (16 130 kg/m)
Frame Height (Unloaded)	40" (7.62 m)
Exhaust Position	Horizontal Left Side

For more information, product demonstration, or details on purchase, lease and rental plans, please contact your local Terex Cranes dealer.

We reserve the right to amend these specifications at any time without notice. The only warranty applicable is our standard written warranty applicable to the particular product and sale. We make no other warranty, expressed or implied.



Simple, available and
cost effective™

Waverly Operations
106 12th Street S.E.
Waverly, IA 50677-9466 USA
TEL: (319) 352-3920
FAX: (319) 352-5727
E-MAIL: inquire@terexwaverly.com
WEB: <http://www.terex.com>



STOCK NO. 13006
1985 IHC BRONTO BRIDGE INSPECTION TRUCK



S1900 CAB
DT-466 DIESEL ENGINE
MT-640 ALLISON AUTOMATIC
TRANSMISSION
ACTUAL MILEAGE: 22,000 MILES
SPOKE WHEELS
10.00 X 20 TIRES
19 FT. FACTORY ALUMINUM FLAT BED
BODY
POWER STEERING
AIR BRAKES

34'L X 98"W X 11'H
219" WB
152" CA
TOTAL LENGTH OF THE TRUCK WITHOUT
BOOM OVERHANG: 31'1"

UNDERBRIDGE REACH FROM RAIL:
26 FEET
HORIZONTAL REACH: 49 FT.
VERTICAL PLATFORM HEIGHT: 60 FT.
PLATFORM CAPACITY: 600 LBS.
(4) UNDERSLUNG TOOL BOXES
(4) OUTRIGGERS

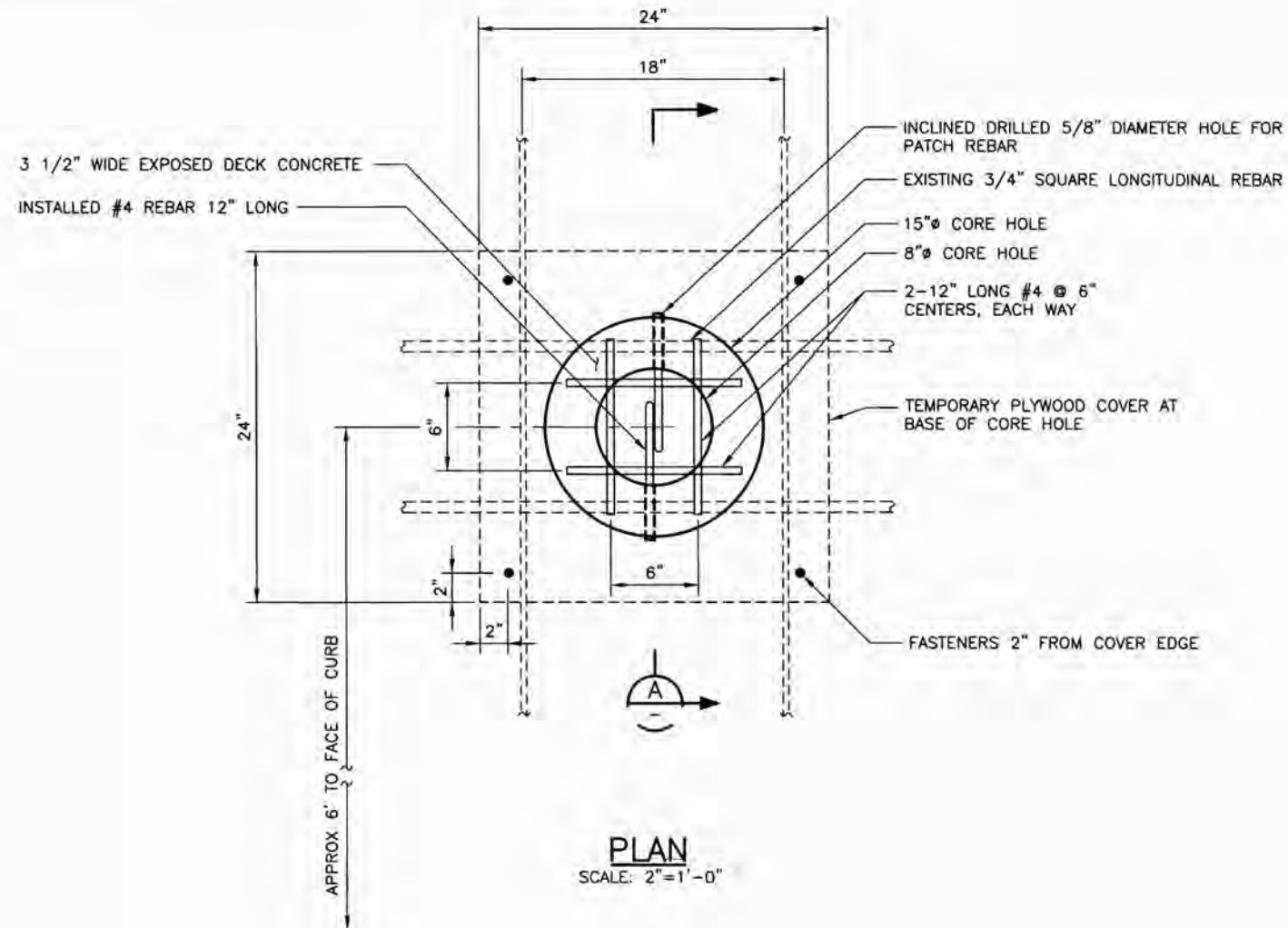

PLAN
SCALE: 2"=1'-0"

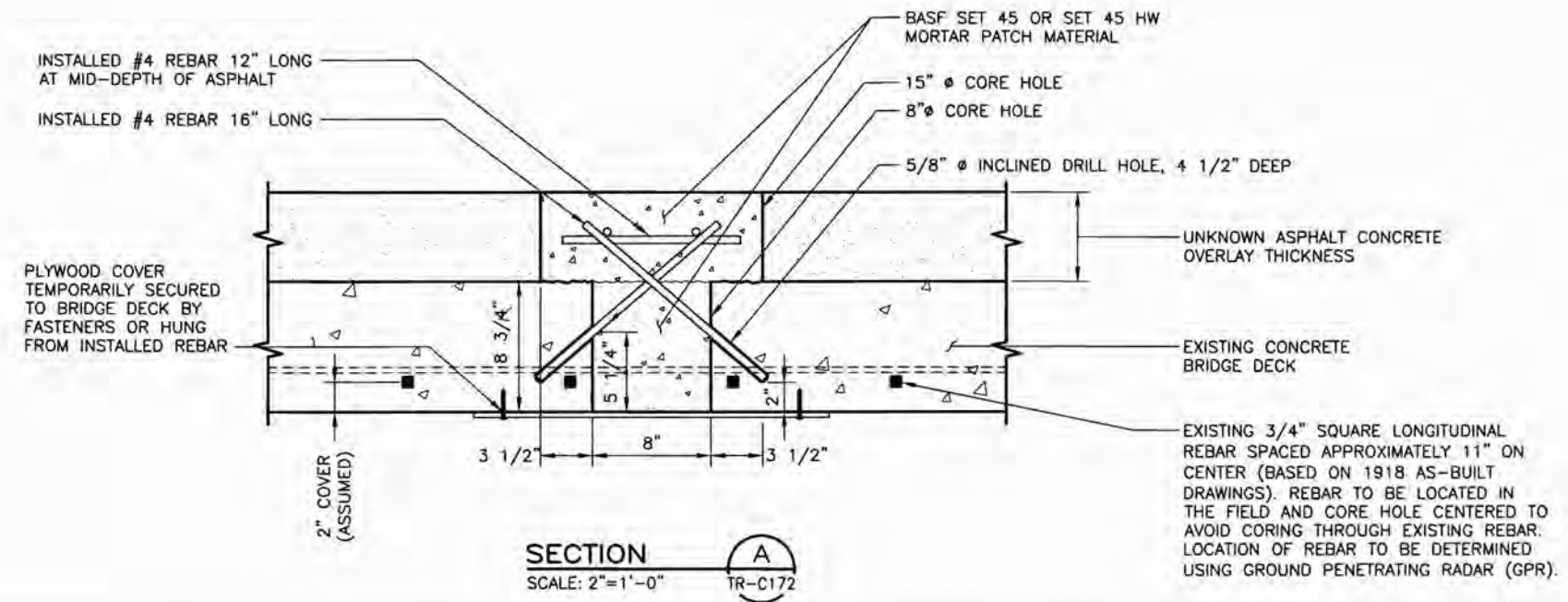

SECTION
SCALE: 2"=1'-0"
A
TR-C172

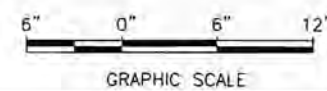

NOTES AND SPECIFICATIONS:

1. PATCHING FOR BACK FILLING OF CORE DRILLED HOLES SHALL BE BASF SET 45 CHEMICAL ACTION MORTAR, ACHIEVING 5000 PSI WITHIN 3 HOURS. SET 45 HW WILL BE REQUIRED IN LIEU OF SET 45 IF AMBIENT TEMPERATURES AT THE TIME THE PATCH IS INSTALLED EXCEED 85 F.
2. 8" DIAMETER CORE DRILLED FOR BOREHOLE.
3. 15" DIAMETER CORE DRILLED FOR TOP HALF OF HOLE THROUGH ASPHALTIC CONCRETE.
4. NO CONCRETE OR DEBRIS SHALL BE ALLOWED TO FALL INTO COYOTE CREEK.

CONSTRUCTION SEQUENCES:

1. DETECT THE LOCATION OF EXISTING EMBEDDED REBAR USING GROUND PENETRATION RADAR (GPR) WITHIN 24" OF THE DEFINED CENTER COORDINATES OF BOREHOLE.
2. ADJUST CENTER OF CORE HOLE TO AVOID CORING THROUGH EXISTING REBAR.
3. DRILL 8" DIAMETER CORE HOLE THROUGH ENTIRE THICKNESS.
4. DRILL 15" DIAMETER CORE THROUGH FULL DEPTH OF ASPHALTIC CONCRETE AND TERMINATE AT TOP OF CONCRETE BRIDGE DECK.
5. INSERT 8" NOMINAL STEEL CASING FOR DRILLING, TO BE PERFORMED WITHIN A CLOSED SYSTEM.
6. PERFORM SOIL INVESTIGATION.
7. DRILL 5/8" DIAMETER HOLE AT FLATTEST ANGLE POSSIBLE INTO THE LOWER COREHOLE SIDE WALL CENTERED 5 1/4" UP FROM THE BASE OF THE BRIDGE DECK. TWO HOLES ARE REQUIRED, AND MUST ONLY BE DRILLED AT EITHER THE TRANSVERSE OR LONGITUDINAL CARDINAL POINTS OF THE HOLE FOR INTERNAL REBAR CLEARANCE. DRILL HOLE DEPTH SHALL BE BETWEEN 4" AND 4 1/2" MEASURED FROM THE LOWER LIP OF THE DRILLED HOLE.
8. INSTALL A 16" LONG #4 REBAR DOWEL INTO EACH DRILLED HOLE.
9. INSTALL TEMPORARY PLYWOOD COVER AGAINST UNDERSIDE OF BRIDGE DECK AND SECURE WITH EITHER FASTENERS OR HANG WITH WIRE FROM INSTALLED CROSSING REBAR. BOARD SHALL BE INSTALLED WITH SEALANT TO PREVENT LEAKAGE DURING PATCHING OPERATION.
10. PATCH THE CORED HOLE WITH BASF SET 45 OR SET 45 HW 5000 PSI MORTAR AND REOPEN TO TRAFFIC AFTER 1 HOUR.

Aug 13, 2009 - 4:03pm W:\UCAD\Engineering\Business\Microsites\For us\isacson\0300-5-TR-C172-A.dwg
 WHITE, J

DESIGNED BY I ISAACSON	SE 2023
DRAWN BY M WHITE	Exp. 11/31/09
CHECKED BY A MILLER	
IN CHARGE C. WU	
DATE 20090813	



HMM / BECHTEL

A Joint Venture of Hatch Mott MacDonald T&T, Inc. and Bechtel Infrastructure Corp.

SUBMITTED _____ APPROVED _____



SILICON VALLEY RAPID TRANSIT PROJECT
CENTRAL AREA GUIDEWAY

COYOTE CREEK SOIL INVESTIGATION
BRIDGE CORING AND RESTORATION PLAN

CADD FILENAME D300-S-TR-C172-A.dwg	REV. A
SIZE D	SCALE 2"=1'-0"
CONTRACT NO. D300	PAGE NO. A
AREA CODE SHEET NO. TR C172	