

# Chapter 5

## NEPA Alternatives Analysis of Construction

---

### 5.1 Introduction

This chapter provides a discussion of preconstruction, construction, and testing and commissioning activities that would occur under the BART Extension Alternative. Preconstruction activities include final design and engineering, relocation planning and right-of-way (ROW) acquisition, utility relocation, and demolition. The BART Extension construction activities have been grouped into the following categories: tunnel, trackwork, and ventilation structures; station and ancillary facilities construction; system installation; end-of-line facilities construction; and revenue vehicle procurement. Testing and commissioning involves system integration testing and commissioning and a revenue service phase. Figure 5-1 provides a schedule for these activities.

VTA would be responsible for construction of the BART Extension in accordance with the VTA/BART Comprehensive Agreement, including implementation of the mitigation measures associated with construction. Once construction is complete, BART would operate and maintain the system.

The No Build Alternative projects (highway, transit, bicycle, and pedestrian improvements) would have the typical air quality, biology, cultural, hazardous materials, traffic, and noise construction effects and mitigation measures associated with these types of projects. Projects planned under the No Build Alternative would, however, undergo separate environmental review to determine whether the projects would result in construction impacts. Therefore, the No Build Alternative is not discussed in detail in this chapter.

### 5.2 Preconstruction Activities

Although many activities would occur before construction of the BART Extension, the major preconstruction activities are highlighted below.

#### 5.2.1 Final Design and Engineering

Final Design develops engineering work products that can be certified and are considered ready for construction. The BART Extension is currently in the Preliminary Engineering phase, which involves analysis and design work to produce preliminary construction plans, specification, and cost estimates sufficient for environmental analysis. The next step following this environmental analysis process and selection of a preferred project is Final Design, which would bring the plans to 100 percent completion. Final Design would involve completing engineering and design for the track, stations, system facilities, and the Newhall Maintenance Facility.

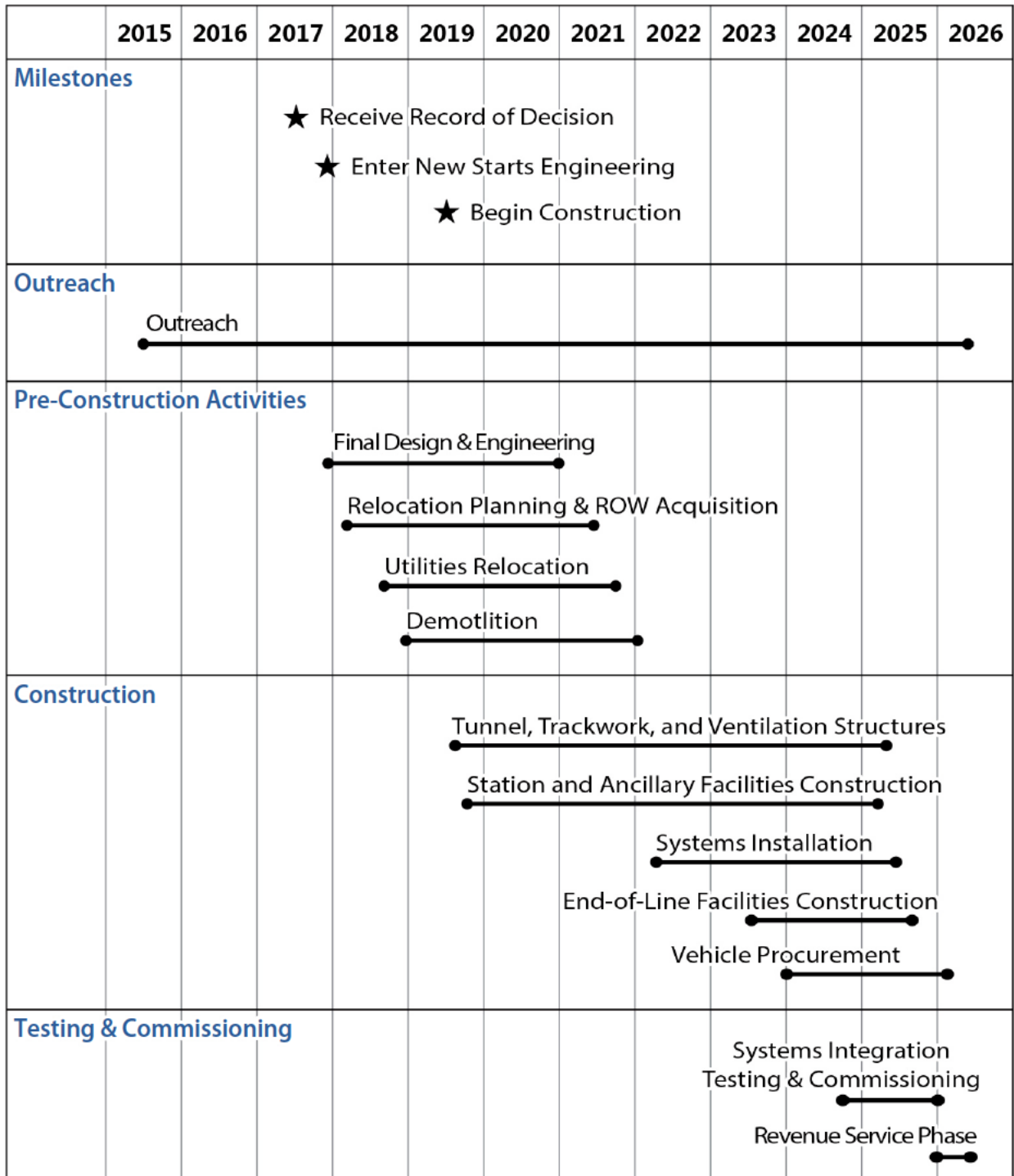

Source: VTA, 2016.

**Figure 5-1**  
**Construction Schedule**  
 VTA's BART Silicon Valley–Phase II Extension Project

Prior to Final Design, VTA would continue to receive input from the public and city partners on certain elements of station design and art work. Design Review Committees will be established with the cities to complete this process. VTA would also work with property owners/developers that are planning new development adjacent to the BART Extension to coordinate Final Design and construction of the BART Extension to reduce adverse construction effects.

During the Preliminary Engineering phase, subsurface exploration consisted of geotechnical borings and cone penetrometer tests. Other tests, including those that measure groundwater levels, were also conducted (see Chapter 4, Section 4.8, *Geology, Soils, and Seismicity*). The results of these investigations have been used to identify proposed design of the BART Extension facilities and construction techniques. During subsequent engineering phases, additional subsurface exploration would be conducted, and the results would be used to detail and finalize excavations and support systems to be used during construction of structure foundations and the retained cut, retained fill, cut-and-cover, and tunnel portions of the alignment. Drilling and well permits would be obtained from the Santa Clara Valley Water District and other agencies as required.

### **5.2.1.1 Preconstruction Business Survey**

Prior to construction, VTA would contact and interview business owners along the alignment to gather information on business usage, delivery/shipping patterns, parking needs, and critical times of the day or year for business activities. The survey would assist in developing actions to reduce impacts on businesses within the BART Extension area by communicating construction impacts and activities to businesses, patrons, services etc.; coordinating and maintaining access to businesses; and maintaining awareness of businesses. Examples of these measures are included in the Construction Education and Outreach Plan described in Section 5.4.1.

### **5.2.1.2 Environmental Permits and Approvals**

VTA would acquire necessary environmental permits and approvals as identified in Chapter 2, Section 2.3.5, *Required Permits and Approvals*. Coordination with permitting agencies is an important aspect of VTA's construction management. In addition, cooperative agreements related to construction activities may be developed with affected agencies and jurisdictions.

## **5.2.2 Relocation Planning and ROW Acquisition**

The BART Extension stations, system facilities, ventilation structures, and construction staging areas near the eastern tunnel portal will all require relocation planning and/or property acquisition. The specific properties will be determined in Final Design. All displacement and relocation activities would be conducted in accordance with the Uniform Relocation Assistance and Real Property Acquisition Act of 1970 (Uniform Act). The Uniform Act ensures fair and equitable treatment for persons whose real property is acquired or who are displaced as a result of a federal or federally assisted project. Government-wide

regulations provide procedural and other requirements (appraisals, payment of fair market value, notice to owners, etc.) in the acquisition of real property and provide for relocation payments and advisory assistance in the relocation of persons and businesses.

VTA's Relocation Program, which complies with federal relocation requirements, provides assistance to affected residence and business owners. This assistance, which varies on a case-by-case basis, can be both financial (e.g., moving costs, rent subsidies, relocation costs, personal property losses, reestablishment expenses, etc.) and technical (e.g., providing information regarding suitable replacement sites, providing referrals, assisting with lease negotiations, assisting with moving logistics, etc.).

Property acquisition is discussed in Section 4.14, *Socioeconomics*. Easements would be required for properties directly above the tunnels. Temporary construction easements and public service easements would also be needed along the alignment to facilitate construction.

### 5.2.3 Utilities Relocation

Utility relocation would be required for underground or overhead utilities depending on the location. Utilities to be relocated would include storm drains, sanitary sewers, water mains, electricity and gas lines, and communication lines. Utilities within the vicinity of cut-and-cover excavations that are in physical conflict with the BART Extension's permanent or temporary structures (cut-and-cover boxes for the portals and stations, station entrances, ventilation shafts, temporary roadway decking, and bored tunnels) would require relocation. A list of existing major utilities along the alignments is included in Section 4.15, *Utilities*. Utility relocation and decking of streets may occur months before major construction activities, as described above. Utility relocation would apply to all options.

### 5.2.4 Demolition

Demolition of existing structures, buildings, pavement, and other site features would be required at various locations along the alignment. Demolition would primarily occur at the four stations and campuses, two mid-tunnel ventilation structure sites, and two tunnel portals. However, demolition may also be required at other locations along the alignment. Aboveground structures identified within the construction staging areas (CSAs), as shown in Figure 5-2 through 5-11, would be demolished to construct the project.



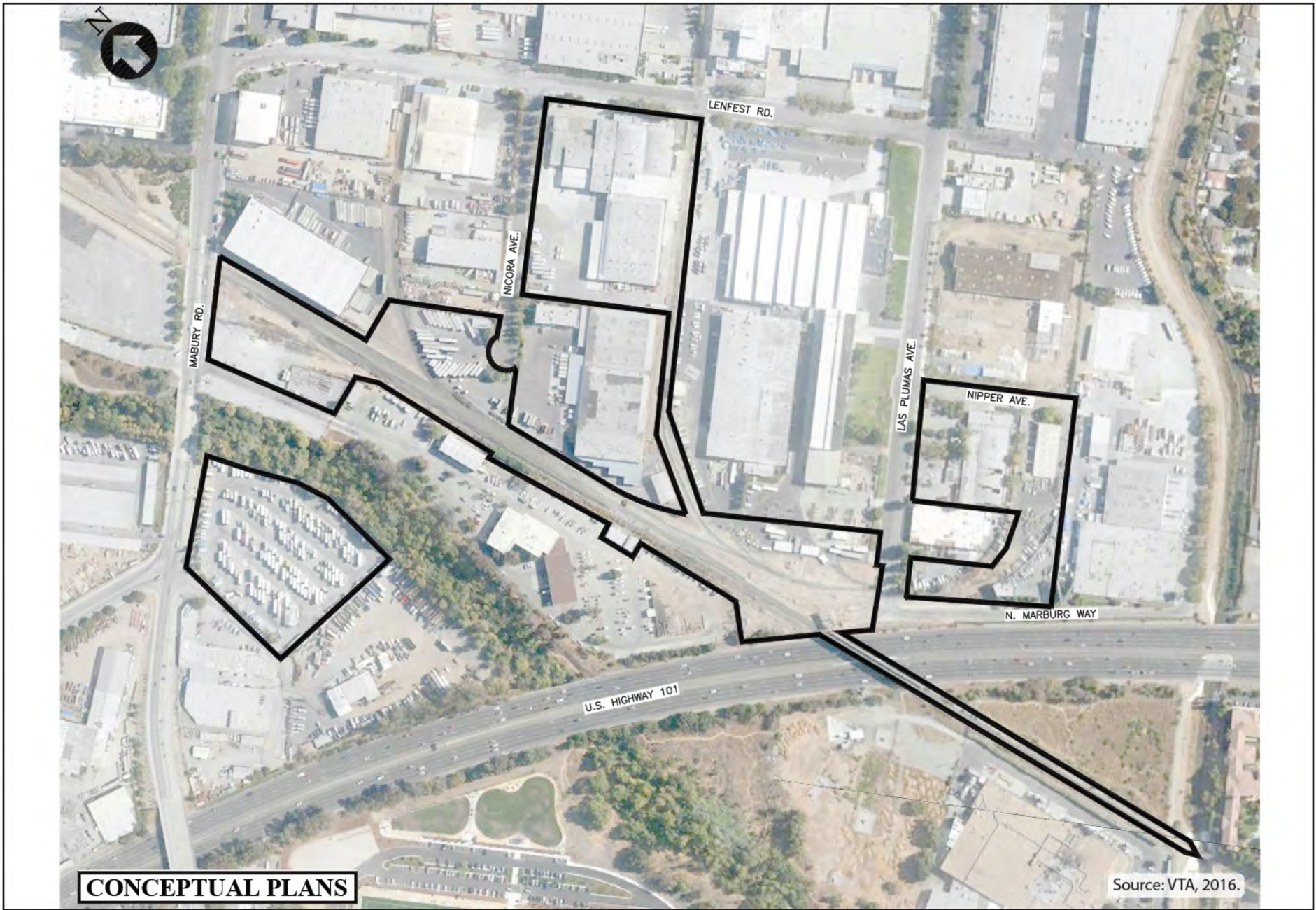

**Figure 5-2**  
**Proposed Mabury Road and U.S. 101 Construction Staging Areas**  
VTA's BART Silicon Valley–Phase II Extension Project





**Figure 5-3**  
**Proposed Alum Rock Construction Staging Areas**  
VTA's BART Silicon Valley–Phase II Extension Project



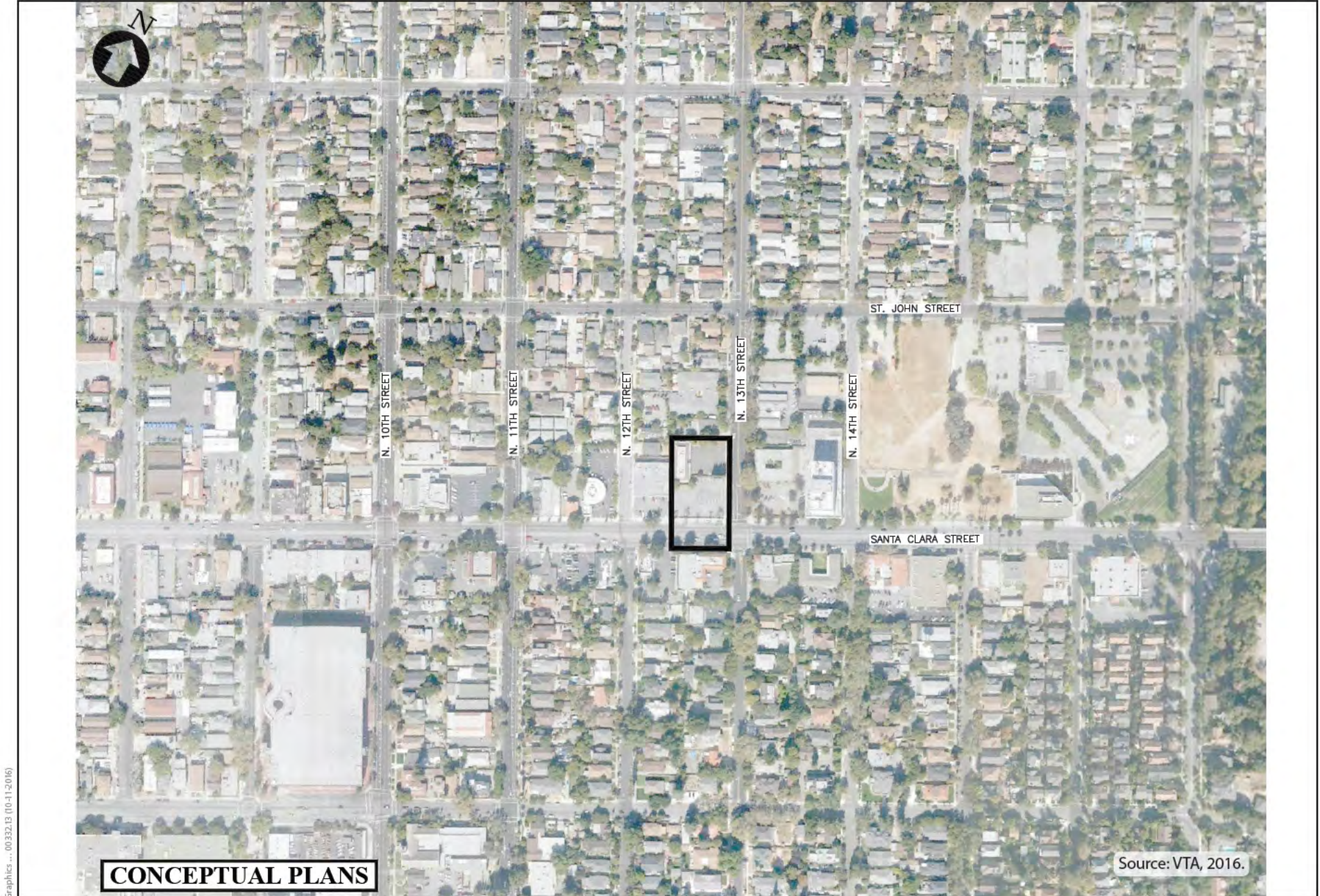

**Figure 5-4**  
**Proposed 13th Street Mid-Tunnel Ventilation Structure Construction Staging Area**  
VTA's BART Silicon Valley–Phase II Extension Project



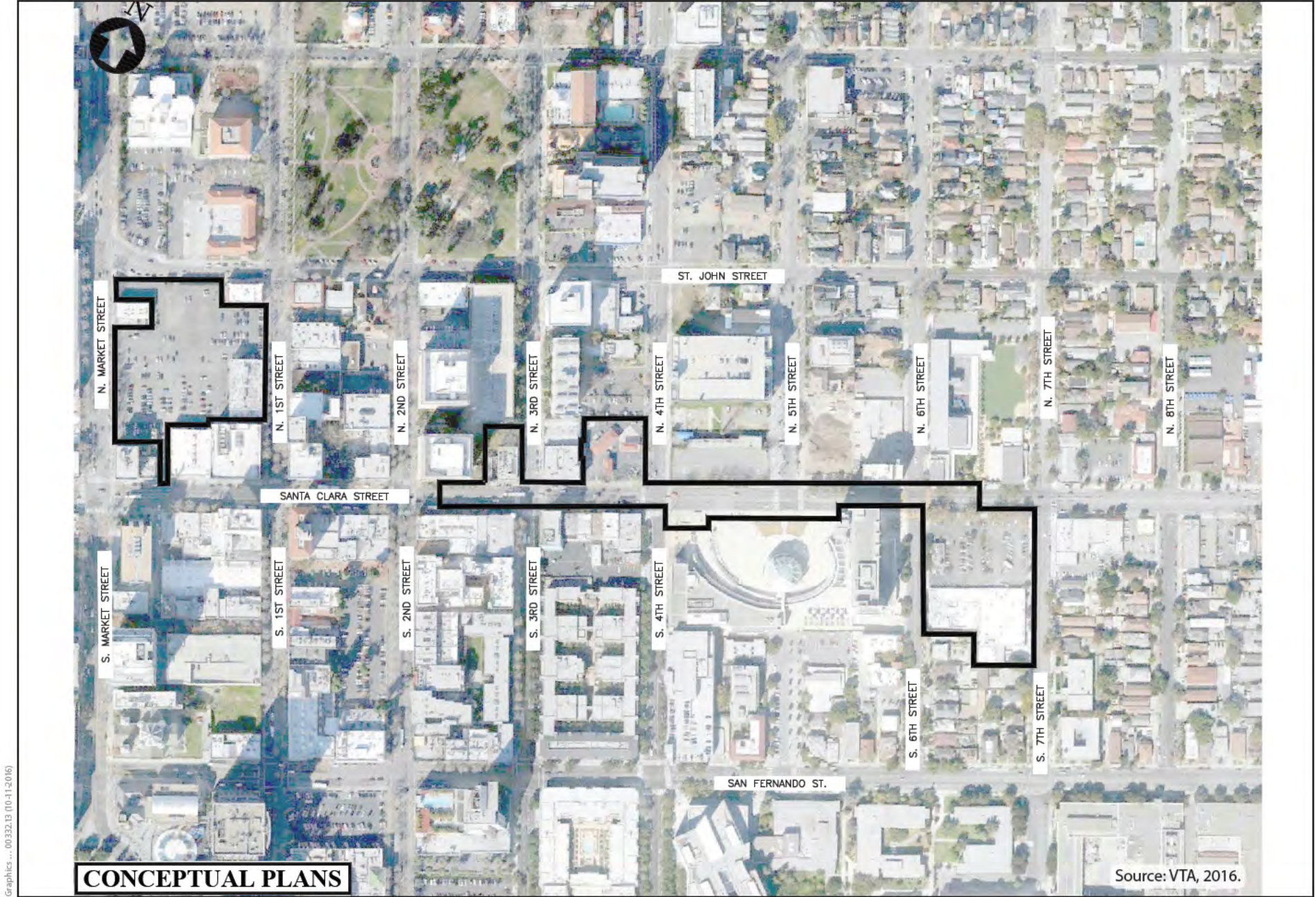

Graphics ... 00332213 (10-11-2016)

**CONCEPTUAL PLANS**

Source: VTA, 2016.

**Figure 5-5**  
**Proposed Downtown San Jose Station East Option Construction Staging Areas**  
 VTA's BART Silicon Valley-Phase II Extension Project



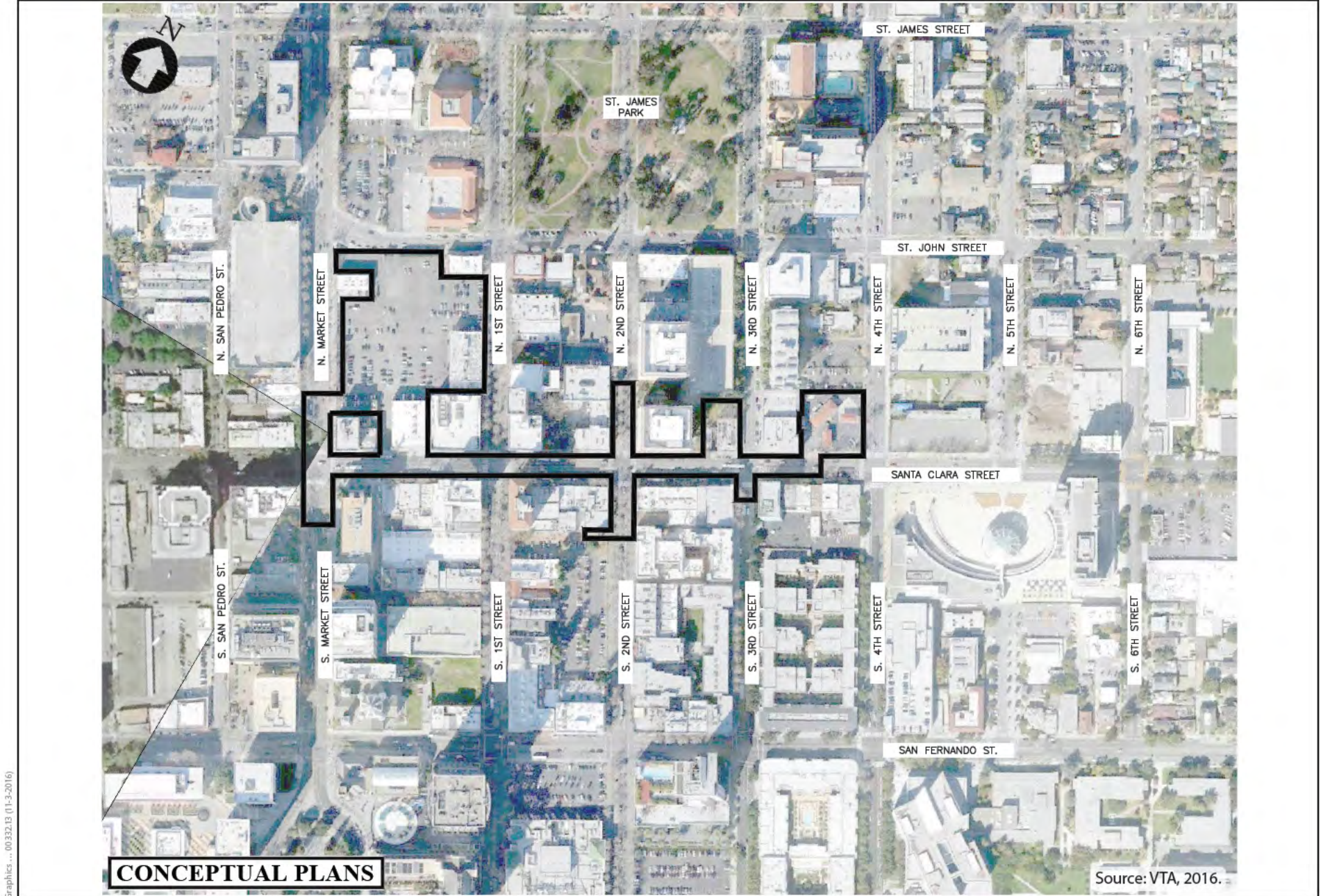

Graphics ... 00332213 (11-3-2016)

**CONCEPTUAL PLANS**

Source: VTA, 2016.

**Figure 5-6**  
**Proposed Downtown San Jose Station West Option Construction Staging Areas**  
 VTA's BART Silicon Valley-Phase II Extension Project



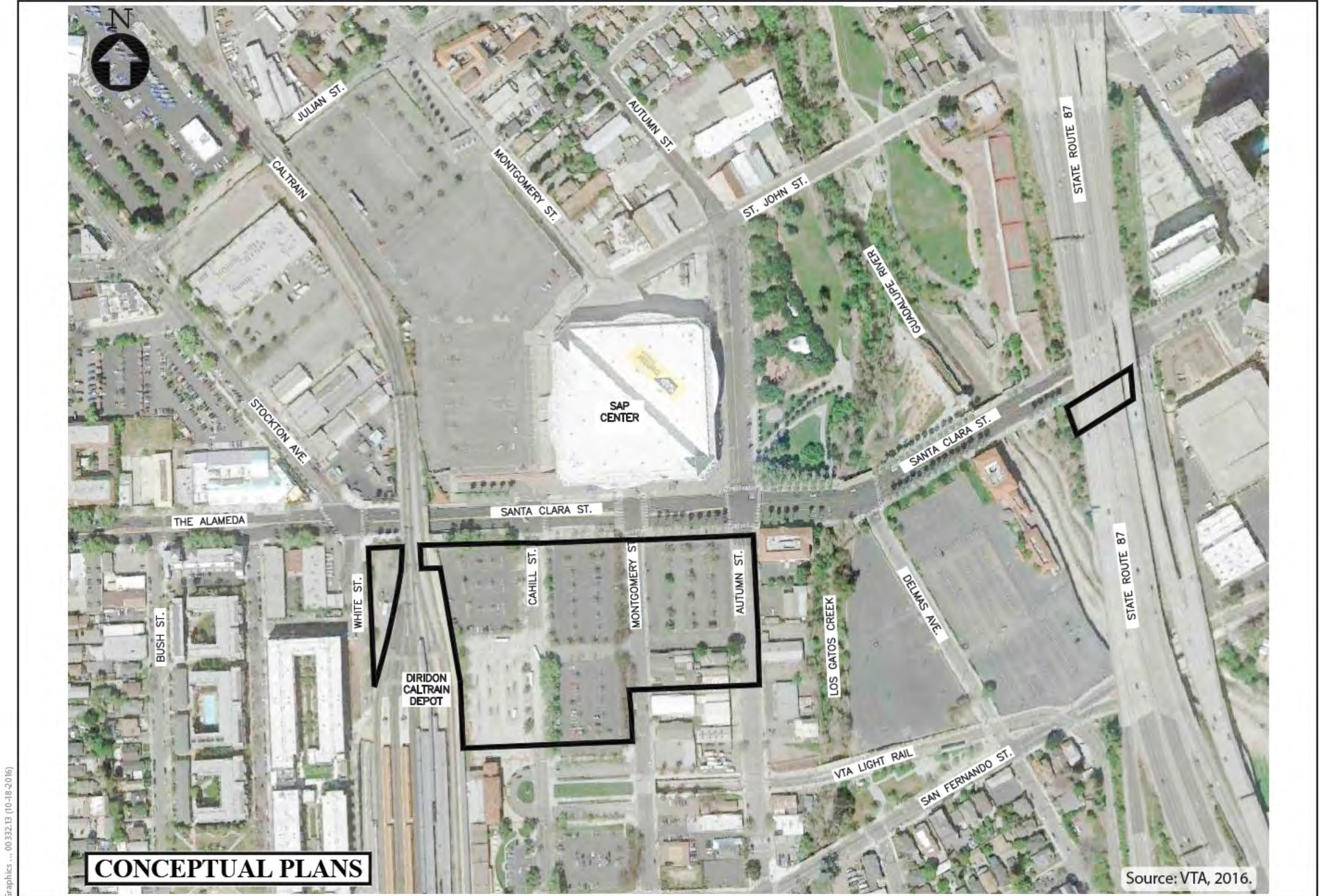

Graphics ... 00332213 (10-18-2016)

**Figure 5-7**  
**Proposed Diridon Station North Construction Staging Area**  
 VTA's BART Silicon Valley–Phase II Extension Project



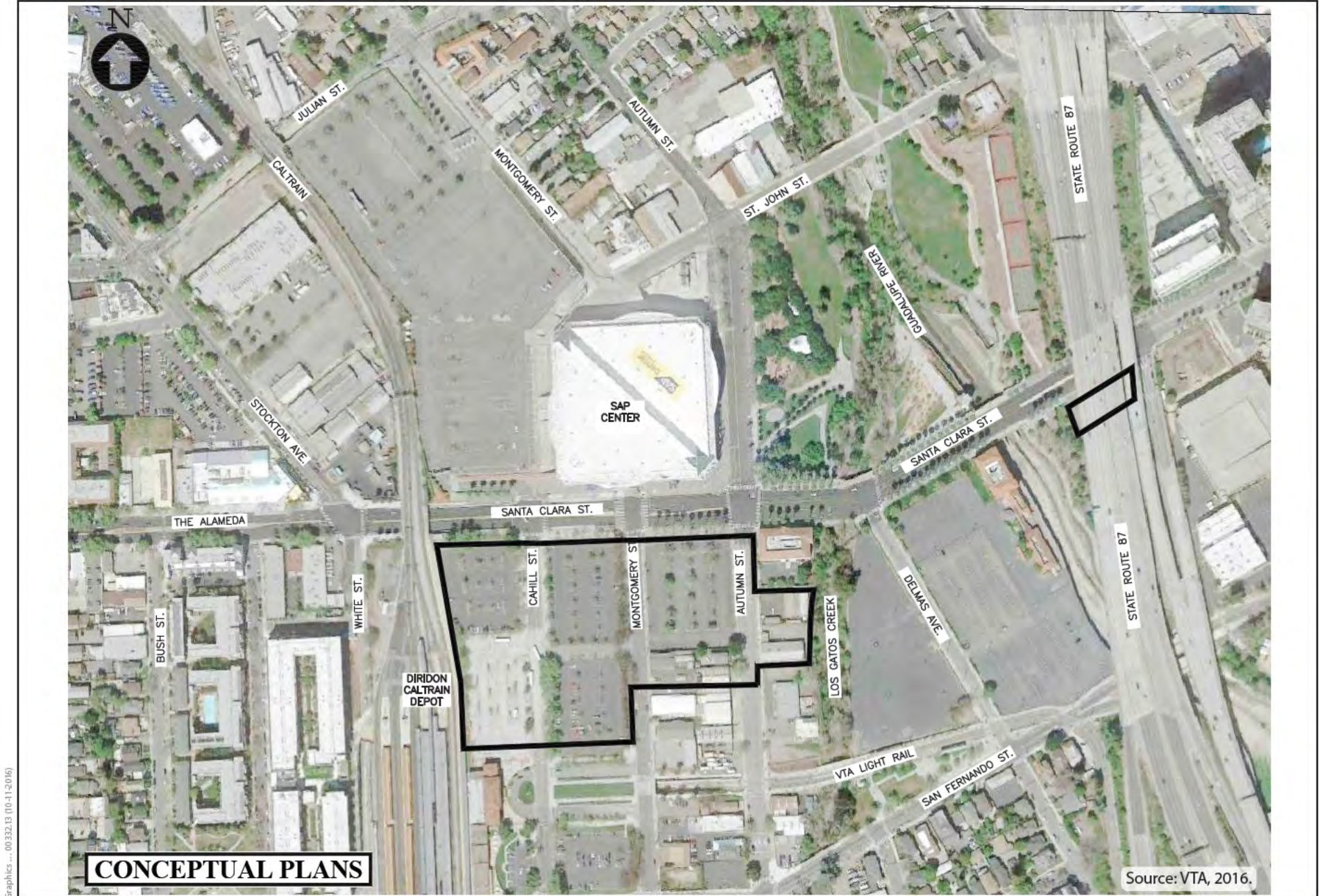

**Figure 5-8**  
**Proposed Diridon Station South Option Construction Staging Areas**  
VTA's BART Silicon Valley–Phase II Extension Project





Graphics ... 00332213 (10-11-2016)

**CONCEPTUAL PLANS**

Source: VTA, 2016.

**Figure 5-9**  
**Proposed Stockton Avenue Mid-Tunnel Ventilation Structure Construction Staging Areas**  
VTA's BART Silicon Valley–Phase II Extension Project



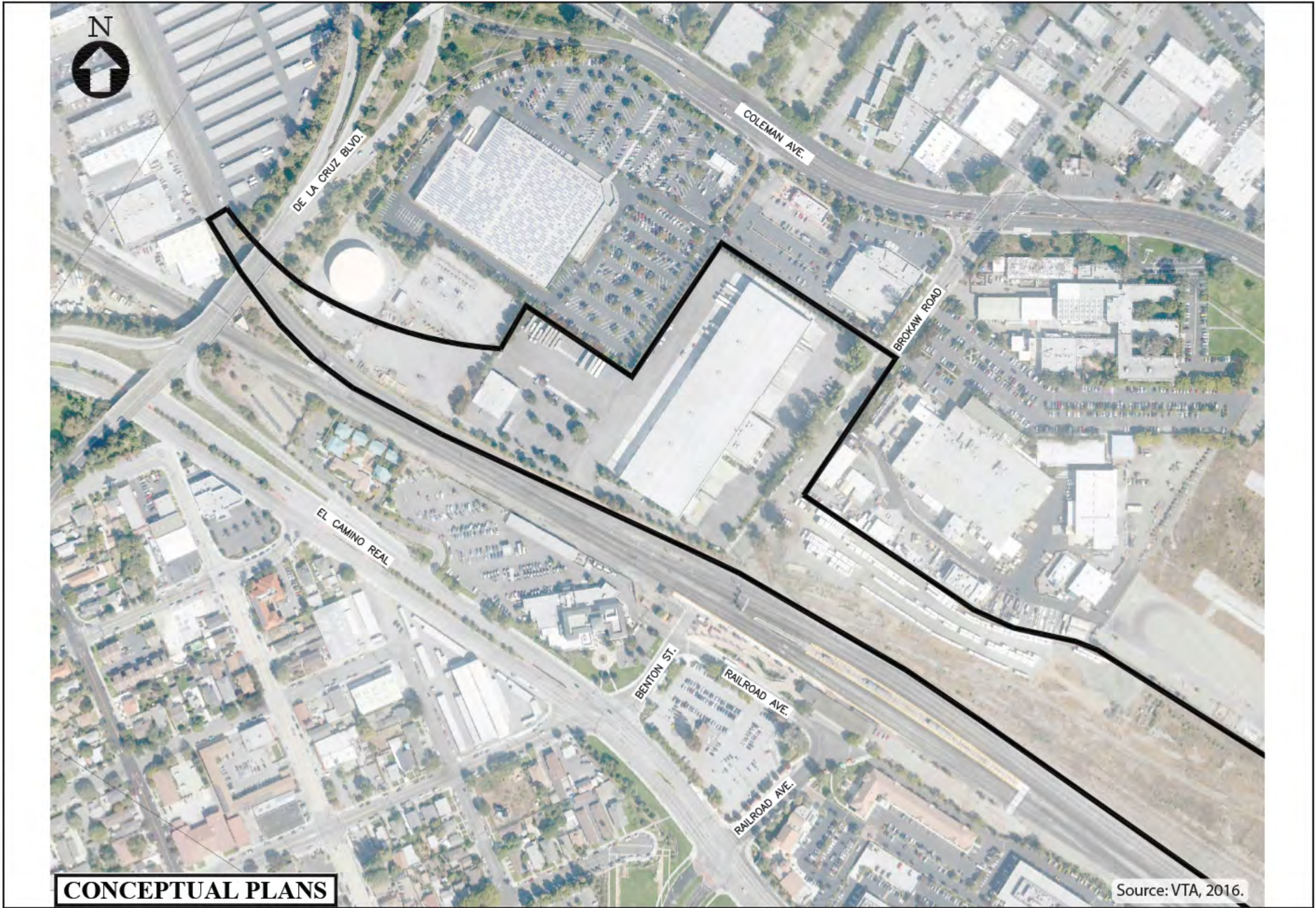

**Figure 5-10**  
**Proposed Santa Clara Station Construction Staging Area**  
VTA's BART Silicon Valley–Phase II Extension Project



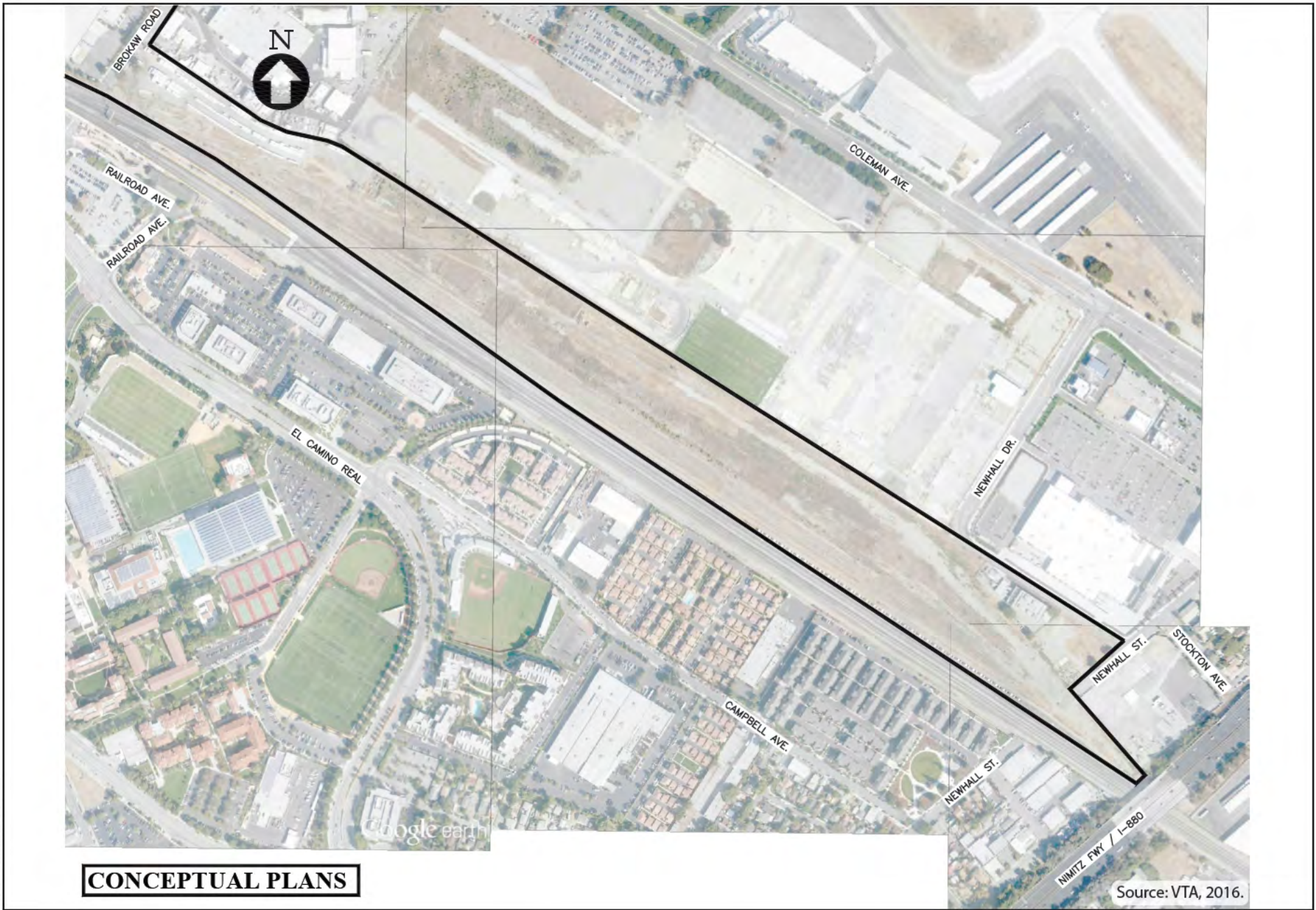

**Figure 5-11**  
**Proposed Newhall Maintenance Facility Construction Staging Area**  
 VTA's BART Silicon Valley–Phase II Extension Project

### 5.2.4.1 Construction Staging Areas

CSAs would be required along the alignment to construct the BART Extension. These areas would be used for construction, construction vehicle parking, construction equipment storage and usage, and materials storage and assembly. Under the Twin-Bore Option, the CSAs at the East and West Tunnel Portals and at the three underground station sites could be utilized for Tunnel Boring Machine (TBM) launch and/or extraction sites and tunnel muck drying and storage prior to off-hauling. Under the Single-Bore Option, the CSAs at the East and West Tunnel Portals would be utilized for the TBM launch/extraction sites, and the West Tunnel Portal CSA would be utilized for the majority of the muck removal, drying, storage, and staging for off-hauling. In addition, the footprints of permanent facilities would be used as CSAs to construct the permanent facilities proposed within those sites.

The following list includes proposed CSAs for the BART Extension, which are shown on Figures 5-2 through 5-11. All of these CSAs would require temporary construction easements or property acquisition (see Section 5.5.15, *Socioeconomics*).

- **Mabury Road and U.S. Highway (U.S.) 101.** This area would include sites both east and west of the railroad ROW between Mabury Road and U.S. 101 as well as additional area within the railroad ROW south of U.S. 101 to Lower Silver Creek. Access to the sites would be from Mabury Road, Nicora Avenue, Lenfest Road, and Las Plumas Avenue.
- **Alum Rock/28<sup>th</sup> Street Station.** This area would include areas along the west side of 28<sup>th</sup> Street from East Julian Street to East San Fernando Street, along the east side of 28<sup>th</sup> Street from East St. James Street to Five Wounds Lane, and along the railroad ROW north of East Julian Street to U.S. 101. Access to the site would be from East Julian Street, McKee Road, 28<sup>th</sup> Street, and Santa Clara Street.
- **13<sup>th</sup> Street Mid-Tunnel Ventilation Structure.** This area would include a site at the northwest corner of the Santa Clara Street and 13<sup>th</sup> Street intersection. Access would be from Santa Clara and 13<sup>th</sup> Streets.
- **Downtown San Jose Station East Option.** This area would include Santa Clara Street from 2<sup>nd</sup> Street to 7<sup>th</sup> Street and sites to the north and south of the street. The first site is south of Santa Clara Street and between 6<sup>th</sup> and 7<sup>th</sup> Streets. The second site is north of Santa Clara Street between 3<sup>rd</sup> and 4<sup>th</sup> Streets. The third site would include an area north of Santa Clara Street between 2<sup>nd</sup> and 3<sup>rd</sup> Streets. The fourth site is north of Santa Clara Street between Market and 1<sup>st</sup> Street and is owned by VTA (the former Mitchell Block site). Access to any of these sites would be from Santa Clara Street and/or along the north/south intersecting streets.
- **Downtown San Jose Station West Option.** This area would include Santa Clara Street from Market Street to 4<sup>th</sup> Street and sites to the north and south of the street. The first site is north of Santa Clara Street between 3<sup>rd</sup> and 4<sup>th</sup> Streets. The second site would include an area north of Santa Clara Street between 2<sup>nd</sup> and 3<sup>rd</sup> Streets. The third site is north of Santa Clara Street between Market and 1<sup>st</sup> Streets and is owned by VTA (the former

Mitchell Block site). The construction area also includes portions of Market, 2<sup>nd</sup>, and 3<sup>rd</sup> Streets north and south of Santa Clara Street. Access to any of these sites would be from Santa Clara Street and/or along the north/south intersecting streets.

- **State Route (SR) 87.** This area is located south of Santa Clara Street and east of the Guadalupe River and would be almost entirely under the SR 87 overpass. Access to the site would be from Santa Clara Street.
- **Diridon Station (South and North Options).** This area would include sites that surround the cut-and-cover station area between Los Gatos Creek, which is east of Autumn Street, to the existing railroad tracks west of Diridon Station. Access to these sites would be from Santa Clara, Cahill, Montgomery, and Autumn Streets.
- **Stockton Avenue Mid-Tunnel Ventilation Structure.** This area would include one of three optional sites located south of Taylor Street, east of Stockton Avenue, and west of the existing railroad ROW. Access to these sites would be from Stockton Avenue.
- **Santa Clara Station.** This area lies to the east of the existing railroad tracks from De La Cruz Boulevard to Brokaw Road. Access to the site would be from Brokaw Road.
- **Newhall Maintenance Facility.** This area would include the Newhall Maintenance Facility located to the east of the existing railroad tracks from Brokaw Road to the north to Interstate (I-) 880 in the south. Access to the site would be from Brokaw Road and Newhall Street.

#### 5.2.4.2 Truck Haul Routes

The BART Extension would require the removal of excavated soil to construct the retained-cut, cut-and-cover, and tunnel segments throughout the alignment, including at the tunnel portals, the station structures and entranceways, the mid-tunnel ventilation structures, the underground crossover, and the bored tunnel(s). Some of the excavated material may be reused on the BART Extension; however, there would still be a considerable amount of material that would need to be hauled away from construction sites.

Table 5-1 presents an estimate of the total volume of material for the BART Extension. This table identifies the haul volumes to be removed from each feature and the estimated number of trucks to haul away the excavated materials for both the Twin-Bore and Single-Bore Options. The peak hour truck volumes are the greatest number of trucks that would access the site during construction in an hour. Typically, the hourly truck volumes would be about two-thirds of these numbers.

**Table 5-1: Haul Road Volumes and Number of Truck Trips for the BART Extension Alternative**

Station/Structure	Haul Volume (Cubic Yards)	Number of Truck Trips	Peak- Hour Truck Volumes
<b>Single-Bore Option Tunnel</b>			
Alum Rock/28 <sup>th</sup> Street Station	25,000	1,250	4
Downtown San Jose Station (East and West Options)	25,000	1,250	4
Diridon Station (South and North Options)	25,000	1,250	4
13 <sup>th</sup> Street Ventilation Structure	4,000	400	2
Stockton Avenue Ventilation Structure	4,000	400	2
West Portal	100,000	5,000	7
East Portal	100,000	5,000	7
Tunnel (muck) – West Portal to East Portal	1,550,000	77,500	22
<b>TOTALS</b>	<b>1,833,000</b>	<b>92,050</b>	—
<b>Twin-Bore Option Tunnel</b>			
Alum Rock/28 <sup>th</sup> Street Station	180,000	9,000	4
Downtown San Jose Station and Crossover Structure (East and West Options)	295,000	14,750	8
Diridon Station (South and North Options)	185,000	9,250	8
13 <sup>th</sup> Street Ventilation Facility	25,000	2,500	4
Stockton Avenue Ventilation Facility	25,000	2,500	4
West Portal	95,000	4,750	7
East Portal	75,000	3,750	11
Tunnel (muck) – West Portal to Downtown San Jose Station	325,000	16,250	5
Tunnel (muck) – East Portal to Downtown San Jose Station	315,000	15,750	5
<b>TOTALS</b>	<b>1,520,000</b>	<b>78,500</b>	—
Source: VTA 2015.			
Note: Peak hour truck volumes refer to the greatest number of trucks operating in any one hour.			

Restrictions on haul routes can be incorporated into construction specifications, and any request by the contractor to change the routes would be subject to approval by the applicable city having jurisdiction. The truck haul routes for the BART Extension Alternative alignment are illustrated on Figure 5-12. The haul routes are designed to minimize travel on local streets prior to accessing U.S. 101, I-280 and I-880, and SR 87. In addition, both the Cities of San Jose and Santa Clara have adopted allowable construction noise periods that would limit the use of trucks for construction (see Table 5-5).



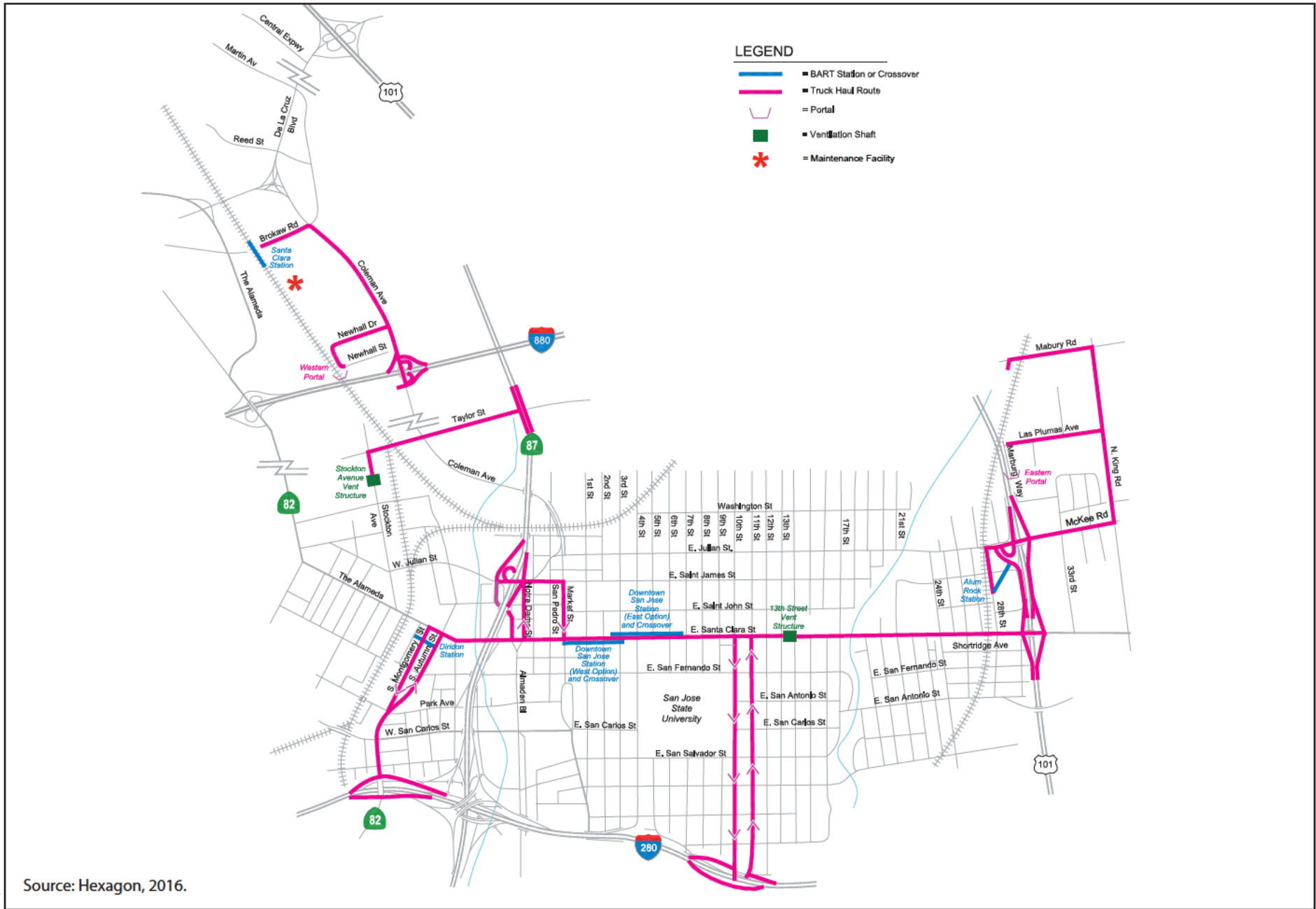

Source: Hexagon, 2016.

Graphics... 003322.13 (6-20-2016)

**Figure 5-12**  
**Truck Haul Routes**  
 VTA's BART Silicon Valley-Phase II Extension Project

## 5.3 Construction Activities

The BART Extension would take approximately 8 years for construction, testing, and start-up activities. Passenger service is expected to start in late 2025/2026, assuming funding is available. The schedule for major construction activities is shown on Figure 5-1. The following provides a description of the major activities.

The construction schedule shown on Figure 5-1 is based on the current plan for construction sequencing and is subject to modification by the contractor. Construction sequencing and scheduling must take into consideration the construction methodology of each BART Extension feature (described below), availability of materials and equipment, available CSAs, and the intent to reduce the overall construction schedule as much as feasible and practicable as well as minimize the duration and severity of impacts on the community.

Typical construction equipment would include backhoes, bulldozers, end-loaders, cranes, wrecking balls, forklifts, haul trucks, jackhammers, excavators, boom drill rigs, crawler cranes, crawler bulldozer/loaders, pavement breakers, loader/bobcats, trucks, excavators, generator/compressors, water trucks for dust control, and concrete and materials/equipment trucks.

Significant oversized equipment would be used extensively, including cranes, bulldozers, loaders, pavement breakers, excavators, and backhoes. A cement slurry batch plant for slurry wall construction may be utilized at cut-and-cover excavation locations

### 5.3.1 Tunnel, Trackwork, and Ventilation Structures

#### 5.3.1.1 Tunnel Boring

For both the Twin-Bore and Single-Bore Options, the average length of the tunnel(s) would be approximately 4.5 miles. The tunnel(s) would be lined with precast concrete segmental linings, which are installed behind the TBM as it moves forward and serve as the permanent waterproof support for the tunnels.

Both options would be constructed using a pressurized closed-faced TBM (Figure 5-13). The purpose of a closed-face machine is to balance the surrounding ground pressure by creating a pressure within the excavation chamber at the front of the TBM. Closed-face TBMs keep out groundwater, stabilize the tunnel face, and minimize settlement. At the front of the cylindrical steel shell, or shield, is a rotating cutterhead (Figure 5-14). As the machine moves forward, it excavates to a predetermined diameter that is dictated by the cutting tool selection and cutter-head configuration. The size of the tunnel diameter is designed for the most extreme horizontal and vertical alignment, taking into account train vehicle envelopes, walkways, trackbed and third rail clearances, drainage facilities, mechanical/electrical equipment, and appropriate tolerances.



Source: VTA, 2011.

**Figure 5-13**  
**Examples of Tunnel Boring Machines**  
VTA's BART Silicon Valley–Phase II Extension Project



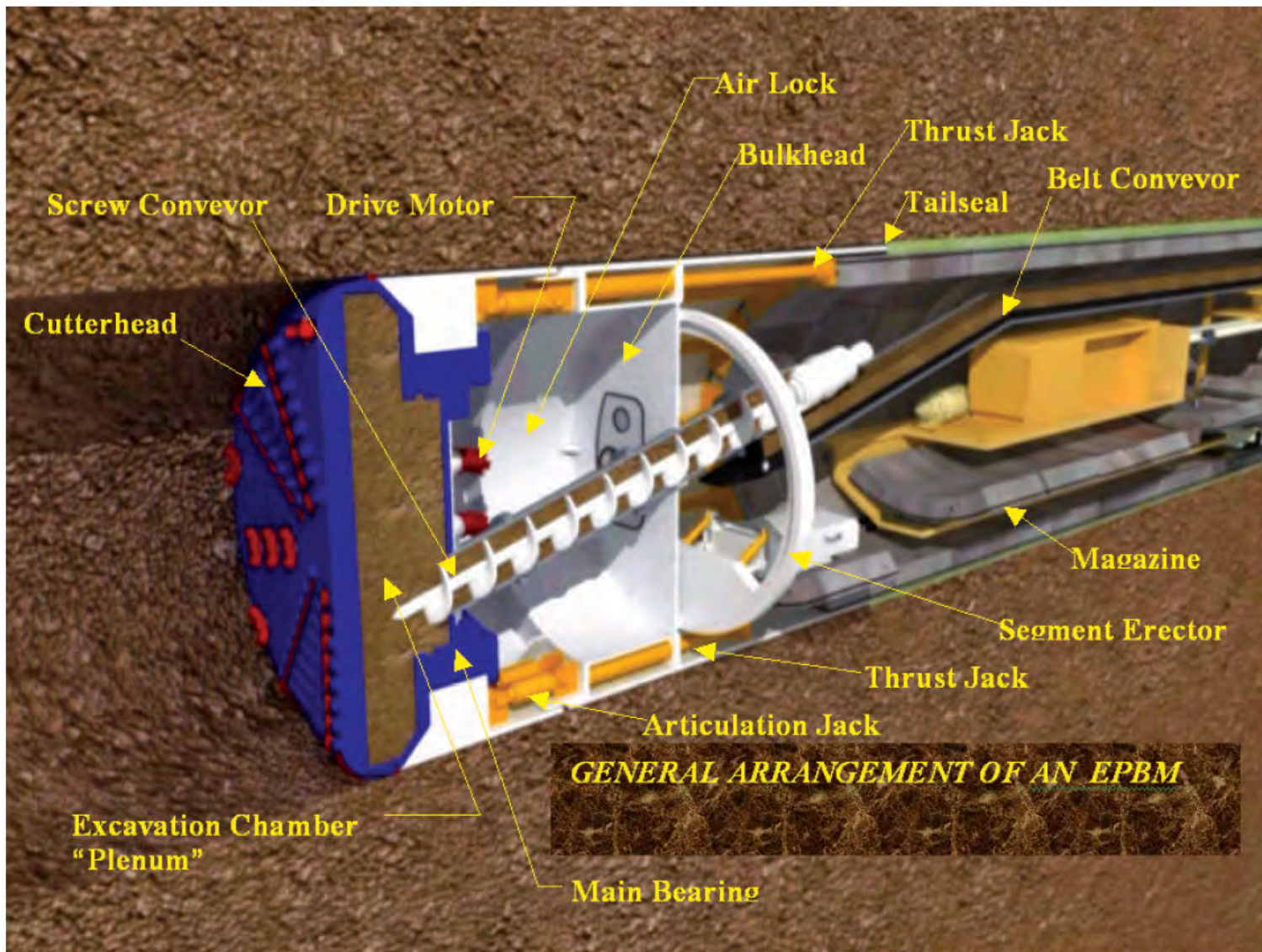

Graphics ... 0033213 (1-14-2016)

Source: VTA, 2011.

**Figure 5-14**  
**General Arrangement of an Earth Pressure Balanced Tunnel Boring Machine**  
 VTA's BART Silicon Valley-Phase II Extension Project

Within the shield, precast concrete segmental lining units are assembled to form the walls of the tunnel with specialized equipment. Six or seven units are mechanically connected to each other to form a single ring that connects to the previous ring. This system is referred to as a Precast Concrete Tunnel Lining (PCTL) and is a one-pass system that has no inner lining; therefore, the rings form the permanent tunnel walls (Figure 5-15). The annular space around the segmental lining units is continuously grouted, and the tunnel lining is made watertight by rubber gaskets around each unit. Once a complete ring is constructed, the TBM thrusts itself off the leading edge of the ring far enough (typically 5 feet) to allow the next ring to be built. Forward propulsion of the TBM is achieved by powerful hydraulic rams installed within the shield reacting off the most recently constructed ring.

While underground, the TBM's excavation chamber is filled with soils excavated from the tunnel face. Conditioning agents are added to the soil in the chamber to aid in maintaining the correct face pressure. By maintaining the chamber pressure close to in-situ (pre-tunneling) water and earth pressure in the ground, the likelihood of groundwater inflows and excessive ground losses are substantially reduced, thereby minimizing ground settlement at the surface. Excavated material called *muck* is removed and transported through the bored tunnels and out the tunnel portals by rail muck cars or by conveyor belts mounted on the sidewalls of the tunnel bores (Figure 5-16). Once outside the tunnel, the muck is stockpiled near the portals or other locations for use as fill material or loaded onto trucks for disposal in accordance with applicable laws and regulations. Areas of over 2.5 acres are available at the East and West Tunnel Portals to accommodate the accumulation of muck from TBM operations. Muck may also be temporarily stored within CSAs. However, with the Single-Bore Option, all of the muck would be removed at the West Tunnel Portal. TBMs have a typical progress rate of 30–75 feet per day depending on soil conditions. This assumes two 10-hour shifts with 4 hours for maintenance activities. Berms would be required to retain wet spoil, and settling/drainage ponds would be required to retain and treat surplus water from the excavated muck.

The potential reuse of muck collected from the tunnel excavation process was evaluated during the Preliminary Engineering design phase to include use as fill above cut-and-cover structures and within mechanically stabilized earth walls of retained-cut structures or use as fill at other nearby construction projects. Reuse of muck in construction of the BART Extension or nearby construction projects would minimize transportation and disposal costs and may require processing of the muck to reduce moisture content and make the soils suitable. However, it should be noted that tunnel muck reuse may not be an option. In that case, such material would be disposed of in accordance with applicable laws and regulations.





Graphics ... 0033213 (6-20-2016)

Source: VTA, 2011.

**Figure 5-15**  
**Example of Segmental Concrete Lining Units and Rings**  
VTA's BART Silicon Valley-Phase II Extension Project



Graphics ... 00382.13 (6-20-2016)

Source: VTA, 2011.

**Figure 5-16**  
**Conveyor System**  
VTA's BART Silicon Valley–Phase II Extension Project

### 5.3.1.2 Tunnel Construction

There are two construction methodologies under consideration to construct the tunnel: the Twin-Bore Option and the Single-Bore Option, as shown in Appendix B and as described below.

Under both options, construction would begin with early utility relocation throughout the 6 miles of the alignment. Roadways would be opened to traffic once utility relocation is complete until the next major construction activity occurs. These activities would include the following for each option.

#### Twin-Bore Option

Under the Twin-Bore Option, two twin-bore tunnels, with one track in each, would be excavated utilizing one or more TBMs. The depth of the tunnels would be between 10 feet below ground surface at the tunnel portals to 75 feet below ground surface to avoid obstructions such as the Santa Clara Street bridge and retaining wall foundations. Each tunnel bore would have an internal diameter of approximately 18 feet. Center-to-center tunnel bore spacing would be approximately 40 feet (Figure 5-17). An example of twin tunnel bores is shown in Figure 5-18.

Under the Twin-Bore Option, major construction activities would begin with the excavation of the twin tunnels by use of one or more TBMs and excavation of the three underground stations (Alum Rock/ 28<sup>th</sup> Street, Downtown San Jose, and Diridon) via a cut-and-cover construction method.

Construction of the tunnels requires the use of one or more TBMs. Under the Twin-Bore Option, two separate side-by-side tunnels would be excavated between the East Tunnel Portal and the West Tunnel Portal. Each tunnel would contain one set of tracks: one for northbound trains and one for southbound trains. The TBM used for the Twin-Bore Option would be approximately 20 feet in diameter. The number of TBMs to be used would depend on the availability of equipment and the contractor's schedule. Tunnels constructed with TBMs are designed to have at least twice the diameter of the tunnel in soil above the tunnel to minimize settlement. Therefore, the crown, or top, of the tunnel of the Twin-Bore Option would be, on average, 40 feet below the surface.

The sequence and direction of travel of the TBM would be determined by the contractor prior to construction. For environmental analysis purposes, this document analyzes the following construction sequence for this option. The TBM would be transported to and assembled within the Newhall Maintenance Facility just north of I-880 near the West Tunnel Portal. The TBM would begin tunneling at the West Tunnel Portal and head southeast toward Diridon Station. The station box at Diridon Station may be excavated before the TBM arrives. The TBM would bore through or be dragged through Diridon Station and continue tunneling to the east toward the Downtown San Jose Station, which would be excavated before the TBM arrives.



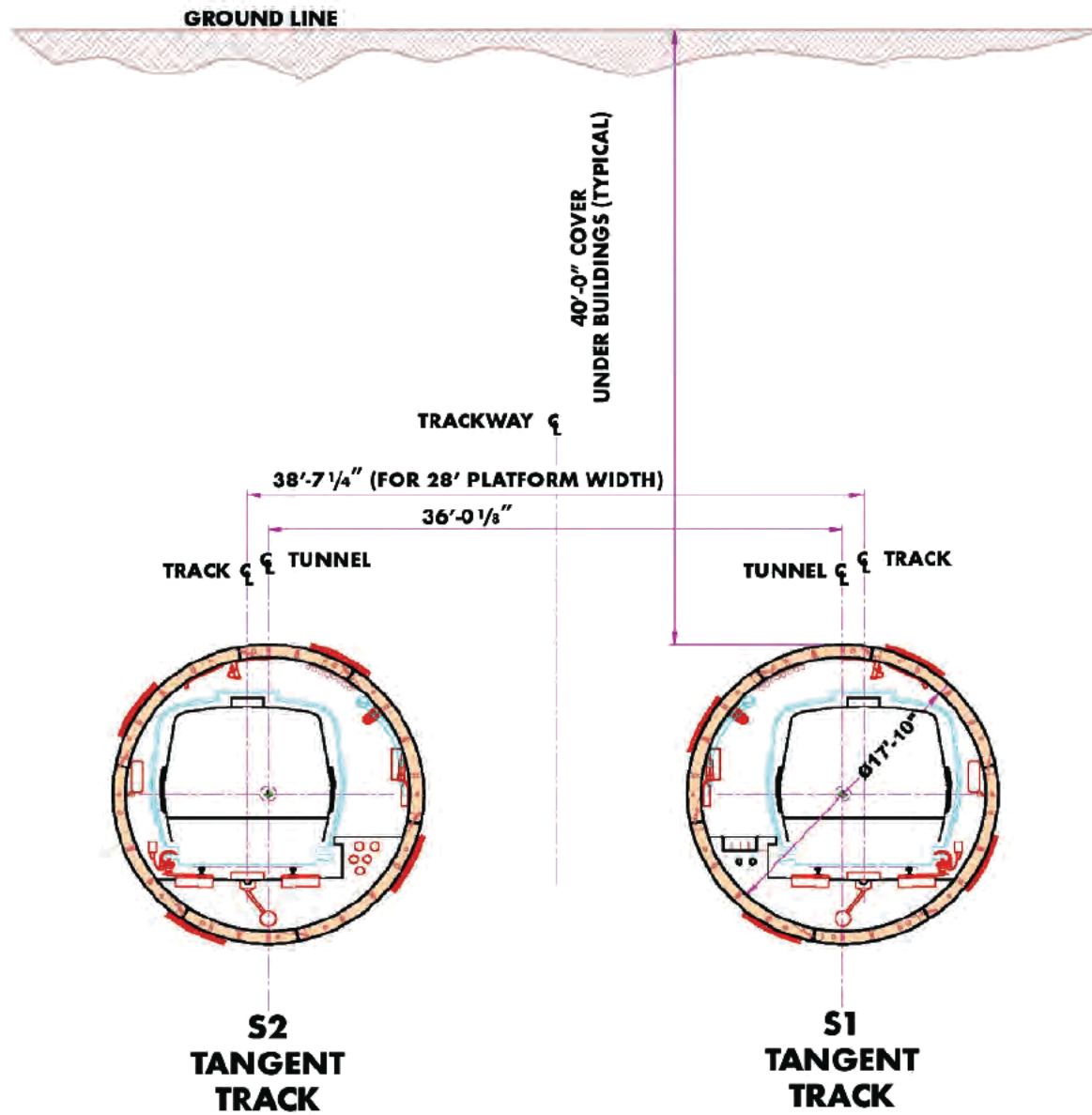

Graphics ... 00332.13 (6-20-2016)

Source: VTA, 2011.

**Figure 5-17**  
**Diameter and Spacing of Tunnel Bores (TRD)**  
 VTA's BART Silicon Valley-Phase II Extension Project



Source: VTA, 2011.

Graphics ... 0033213 (6-20-2016)

**Figure 5-18**  
**Twin Tunnel Bores**  
VTA's BART Silicon Valley–Phase II Extension Project

At the Downtown San Jose Station, the TBM would be dismantled and removed through the station box by a large crane erected over the station box. The TBM would be transported by truck to the East Tunnel Portal and reassembled. Tunneling would resume from the East Tunnel Portal toward Alum Rock/28th Street Station, which may be excavated before the TBM arrives. The TBM would bore through or be dragged through Alum Rock/ 28<sup>th</sup> Street Station and continue tunneling toward Downtown San Jose. The TBM would be removed again from the Downtown San Jose Station. If one TBM is used, this process would be repeated until tunneling is complete. If two TBMs are used, the TBMs would follow the same process, but one would have a head start to keep a safe distance between the two to avoid increased settlement. The excavation of the three underground stations may occur simultaneously or consecutively depending on many factors. The construction sequencing described above applies to both the Downtown San Jose Station East and West Options and both the Diridon Station South and North Options. The contractor may use the CSAs at the East and West Tunnel Portals and at the Alum Rock/28th Street, Downtown San Jose, and Diridon Stations for construction of the tunnel, including launch and extraction sites for the TBM, storage of equipment and materials for the tunnel, and the removal and storage of tunnel muck. Although the description above includes the dismantling and removal of the TBM from the Downtown San Jose Station, the contractor may dismantle and remove the TBM from any of the three underground stations or either of the East or West Tunnel Portals.

### **Single-Bore Option**

Under the Single-Bore Option, one large-diameter tunnel bore would be excavated starting at the West Tunnel Portal to the East Tunnel Portal. The tunnel bore would have an internal diameter of approximately 40 feet (with an outer diameter of approximately 45 feet) with the tunnel depth at about 70 feet (average) below ground surface (Figure 5-19) (EPC Consultants, Inc. 2016).

Under the Single-Bore Option, major construction activities would begin with excavation of one approximately 45-foot-diameter tunnel beginning from the West Tunnel Portal and moving eastward to the East Tunnel Portal. The single tunnel would contain two sets of tracks: one for northbound trains and one for southbound trains. The northbound and southbound tracks would be stacked one over the other within the tunnel at the three underground stations; however, the tracks could be side-by-side, stacked vertically, or in transition of those two configurations depending on the location within the BART Extension alignment (Figure 5-20). The TBM used for the Single-Bore Option would be approximately 45 feet in diameter. The tunnel would be designed to a depth of at least one and one-half diameters of soil above the tunnel to minimize settlement. The crown, or top, of the tunnel of the Single-Bore Option would be, on average, 70 feet below the surface. This depth would maintain a maximum vertical displacement from ground loss due to tunneling of 1 inch at the center of the settlement trough above the TBM.



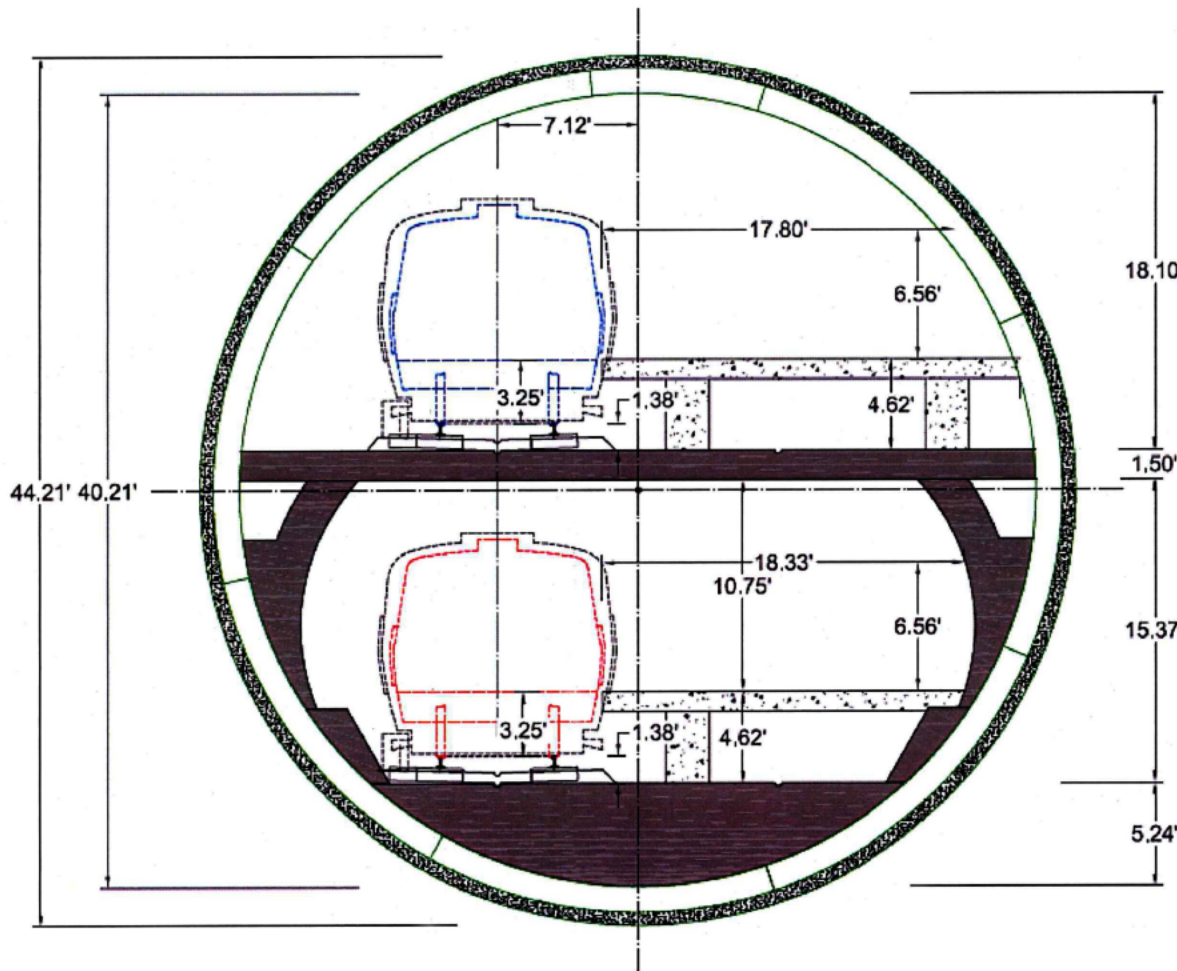

Diameter - 44.2' (13.3 m)

Platform Capacity =  
2,520 passengers @ 5 sf  
per passenger

TYPICAL SECTION IN STATION

Source: VTA, 2016.

Graphics... 00.332.13 (6-20-2016)

**Figure 5-19**  
**Single-Bore Tunnel Cross Section**  
VTA's BART Silicon Valley-Phase II Extension Project

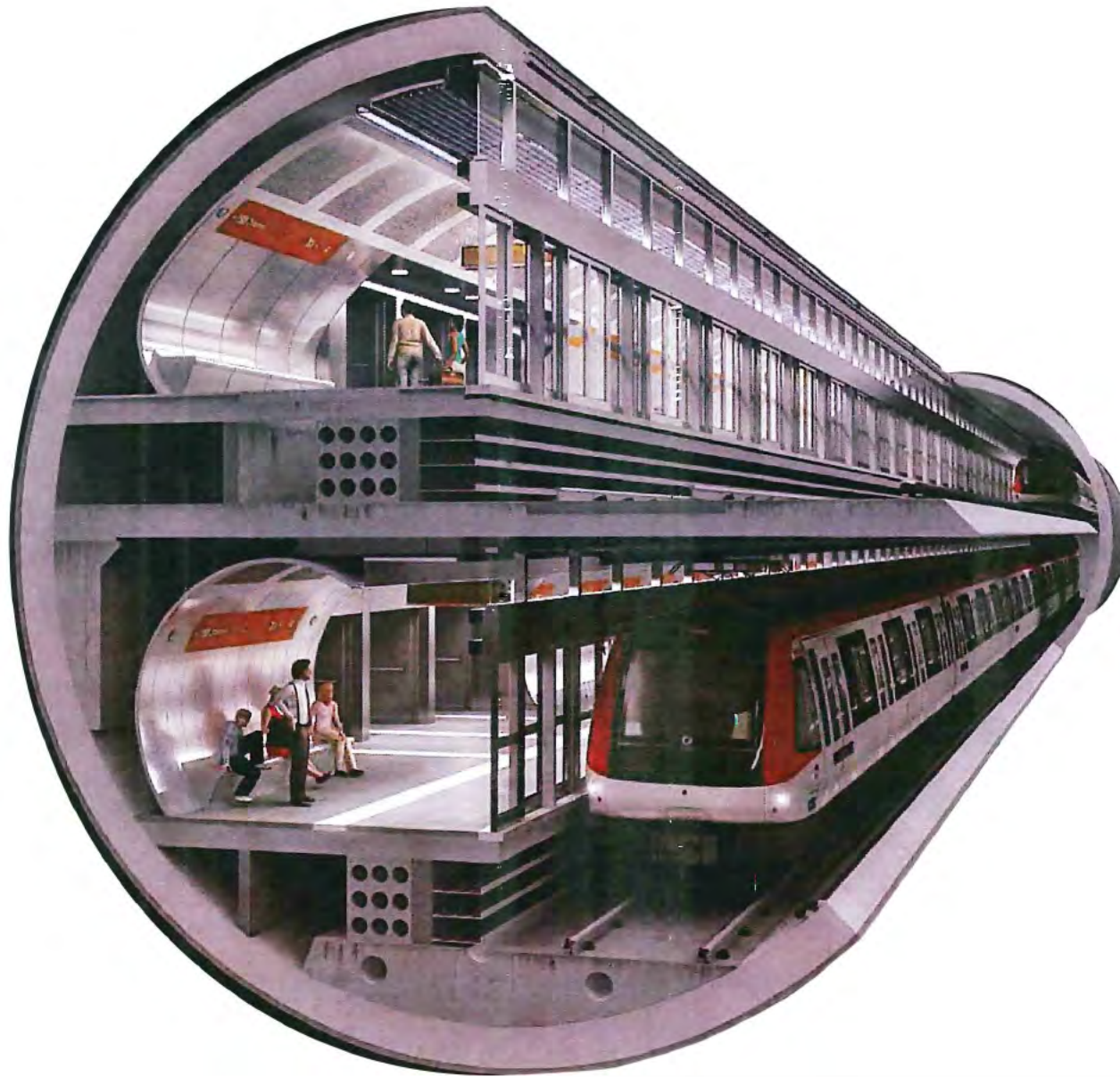

Source: VTA, 2016.

**Figure 5-20**  
**Example of Single-Bore Tunnel Transit System**  
VTA's BART Silicon Valley-Phase II Extension Project

Under the Single-Bore Option, the three underground stations (Alum Rock/28<sup>th</sup> Street, Downtown San Jose, and Diridon) would be adjacent to the tunnel in off-street locations and would contain the concourse with a ticketing agent booth, ticket vending machines, and turnstiles (Figure 5-21). Passengers would access these underground stations by stairs, elevator, or escalators through entrance portals at the surface. These underground stations adjacent to the tunnel would be constructed via a cut-and-cover method concurrently with the tunnel and would connect to the boarding platforms within the tunnel by underground passageways. The station platforms would be located within the tunnel and would be excavated via the TBM, not a cut-and-cover construction method. Excavation of the three underground stations may occur simultaneously or consecutively depending on many factors.

Under the Single-Bore Option, the contractor may use the CSAs at the East and West Tunnel Portals for construction of the tunnel, including launch and extraction sites for the TBM, storage of equipment and materials for the tunnel, and the removal and storage of tunnel muck. According to the proposed construction sequencing, most of the tunnel muck would be removed and off-hauled from the West Tunnel Portal.

The underground connection of the passenger concourse between the entrance and the platforms in the tunnel would be mined using soft ground mining techniques. Extensive ground treatment would be applied to stabilize soil conditions prior to mining.

### **5.3.1.3 Tunnel Boring Machine Power Source**

To provide construction power for operation of the TBMs during construction, a temporary power substation would be located near each tunnel portal, which would be decommissioned and removed after completion of construction. At the East Tunnel Portal, the substation would be supplied from a Pacific Gas and Electric (PG&E) 115 kilovolt (kV) transmission line and would transform the incoming power to 12 kV for service to the TBMs. The substation facility would consist of: 115 kV switchgear; a 115 kV/12 kV transformer; and a 12 kV switchgear enclosure. There are four alternate locations for the temporary substation. The first would be within the San Jose Mabury Yard adjacent to and north of US 101. This substation would be served from a temporary extension of the 115 kV line along Las Plumas Avenue that would ultimately supply High Voltage Substation SMR. The second alternate location would be within a commercial parking area near the end of Las Plumas Avenue and east of the railroad ROW. This substation would be served from the permanent 115 kV line along Las Plumas Avenue. The third alternate location would be on the east side of Nipper Avenue. A fourth location would be at the south end of Nipper Avenue. Both the third and fourth locations would be served from the permanent 115 kV line along Las Plumas Avenue. However, as these sites are the farthest from the railroad ROW, the 12 kV switchgear enclosure would be located closer to the East Tunnel Portal within the commercial parking area near the end of Las Plumas Avenue and east of the railroad ROW.

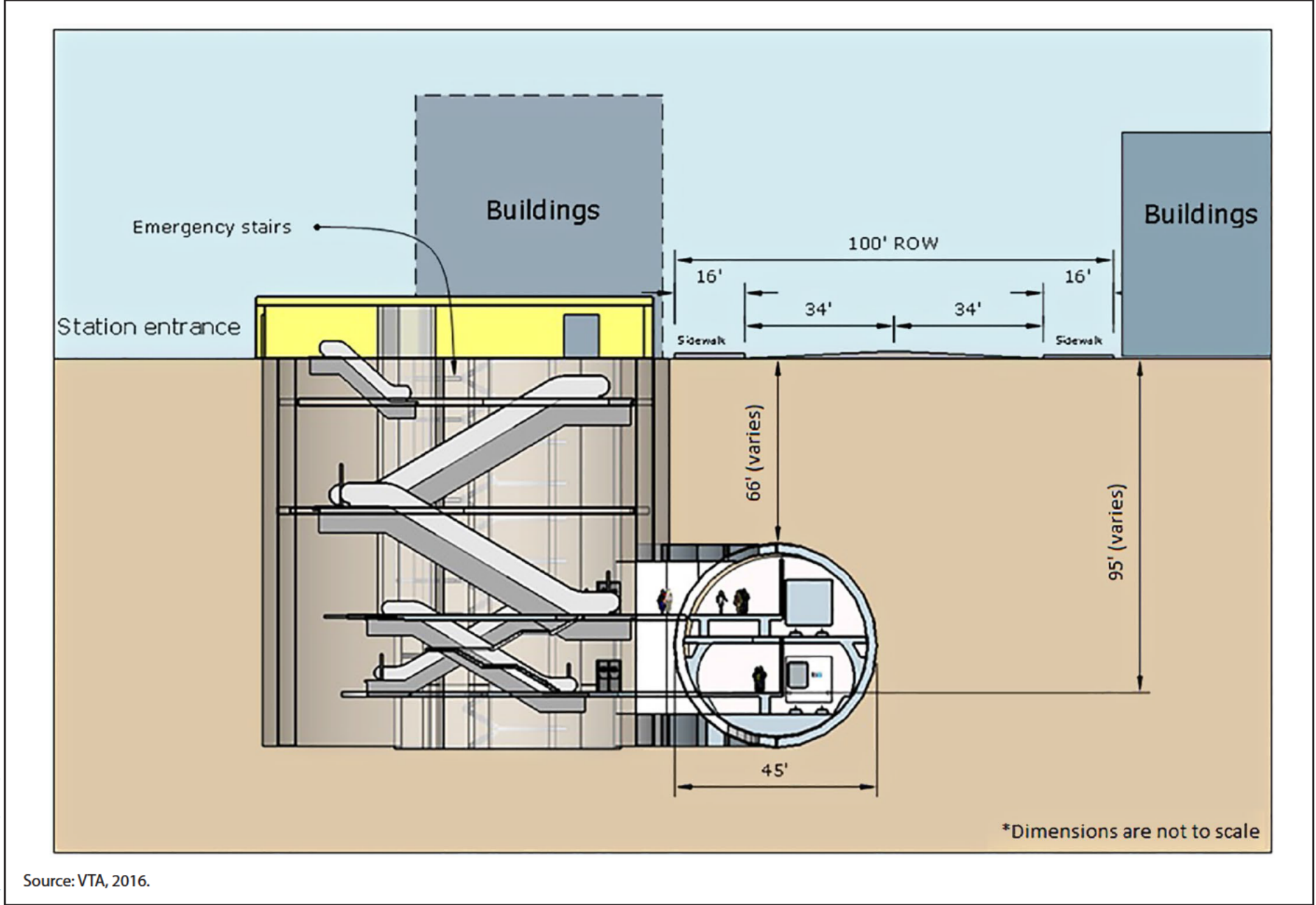

Graphics ... 00.332.13 (12-7-2016)

Source: VTA, 2016.

**Figure 5-21**  
**Example of Single-Bore Tunnel Station**  
 VTA's BART Silicon Valley-Phase II Extension Project

At the west tunnel portal, a temporary power substation would be located at the site of High Voltage Substation SNH. This temporary substation would be served from PG&E's FMC substation by a 115 kV line, which would be constructed to also serve the permanent high voltage substation. There are two alternate routes for this 115 kV line connection. The first would begin at the high voltage substation, run north to Newhall Street, then run east on upgraded poles along Newhall Street, and south on an existing line along Stockton Avenue. A second alternate route would also run north to Newhall Street and then run east on upgraded poles along Newhall Street, but a new line would be constructed to traverse the PG&E substation site.

### **5.3.1.4 Ground Treatment**

Ground treatment may be required during construction of the tunnels for either the Twin-Bore or Single-Bore Option and, for the Single-Bore Option connections to the station concourses and for the Twin-Bore Option cross passages to stabilize variable soils and provide for safe tunneling excavation. There are various ground treatment methods available depending on the intended purpose, localized geotechnical and easement conditions, potentially affected structures and utilities, and adjacent construction activity. These methods include the following:

- Soil replacement using jet grouting to establish consolidated blocks of soil where existing unstable soil is replaced entirely with cement grout or is partially replaced with cement grout that is mixed into the soil to obtain the appropriate strength, permeability, and other engineering characteristics.
- Soil displacement where a slurry material is injected into the soil to replace lost soil and densify loose material.
- Soil modification where permeation grouting with cementitious or chemical grouts is used to increase cohesion and/or strength, reduce permeability, or modify the properties of the soil.
- Ground freezing where soil is treated by using calcium chloride brine, ethylene glycol, ammonia, or liquid nitrogen.
- Dewatering where water is extracted from the soil to reduce pore pressure, resulting in improved soil stability and reduction of ground water level.

Under the Twin-Bore Option, ground treatment of the cross passages would take 1–4 weeks depending on the locations and extent of treatment required. During ground treatment of cross passages located under roadways, reduction of one traffic lane in each direction may be required.

### **5.3.1.5 Emergency Egress**

Emergency egress must be provided for both the Twin-Bore and Single-Bore Options. Under the Twin-Bore Option, the tunnels would be connected to each other by cross passages at



regular intervals (460–750 feet apart) along the tunnel alignment (Figure 5-22). Cross passages allow for passengers who must evacuate a train or a tunnel in an emergency to cross from one tunnel to the other for safety. Cross passages would be excavated from within the bored tunnels through preformed breakout panels installed as part of the tunnel segmental lining units. Installation of equipment and location and routing of utilities and services would be performed after installation of the permanent lining. Under the Single-Bore Option, the tunnel would have two tracks stacked vertically (one within an upper level and one in a lower level) within the tunnel. The upper and lower tracks would be connected to each other by emergency stairways at regular intervals along the tunnel alignment. The emergency stairways allow for passengers to evacuate a directional zone of the tunnel in an emergency and reach the tunnel's other directional zone for safety. The emergency egress stairways would be constructed within the tunnel.

### 5.3.1.6 Guideway Construction

There are three types of transit guideway configurations and construction methodologies for the non-tunnel portions of the BART Extension: at-grade, retained-cut, and cut-and-cover. At-grade and retained-cut construction methodologies are described below; cut-and-cover construction methodology is described in Section 5.3.1.7, *Cut-and-Cover Construction*. The locations where the different types of guideway configurations are utilized along the alignment are shown in Appendix B at the bottom of each plan and profile drawing.

#### At-Grade Configuration

Under both the Twin-Bore and Single-Bore Options, the segment of the BART Extension alignment that would be at grade is from north of the West Tunnel Portal through the Newhall Maintenance Facility to the end of the tail tracks just north of De La Cruz Boulevard. Under an at-grade configuration, the location of the guideway is at the same level as the ground surface. Figure 5-23 shows a conceptual cross section for a BART at-grade guideway. Heavy construction equipment is used to excavate and remove surface material. The excavated material is loaded onto trucks or railroad cars and transported from the site for disposal. Any excavated material that is contaminated is transported to a disposal facility that handles such waste or is encapsulated in fill in accordance with applicable regulations. After removal of the surface material, the subgrade soils are evaluated for their ability to support the guideway. If the subgrade soils are unsuitable for supporting the guideway, they are excavated and re-compacted, treated, or removed and replaced with suitable soils.

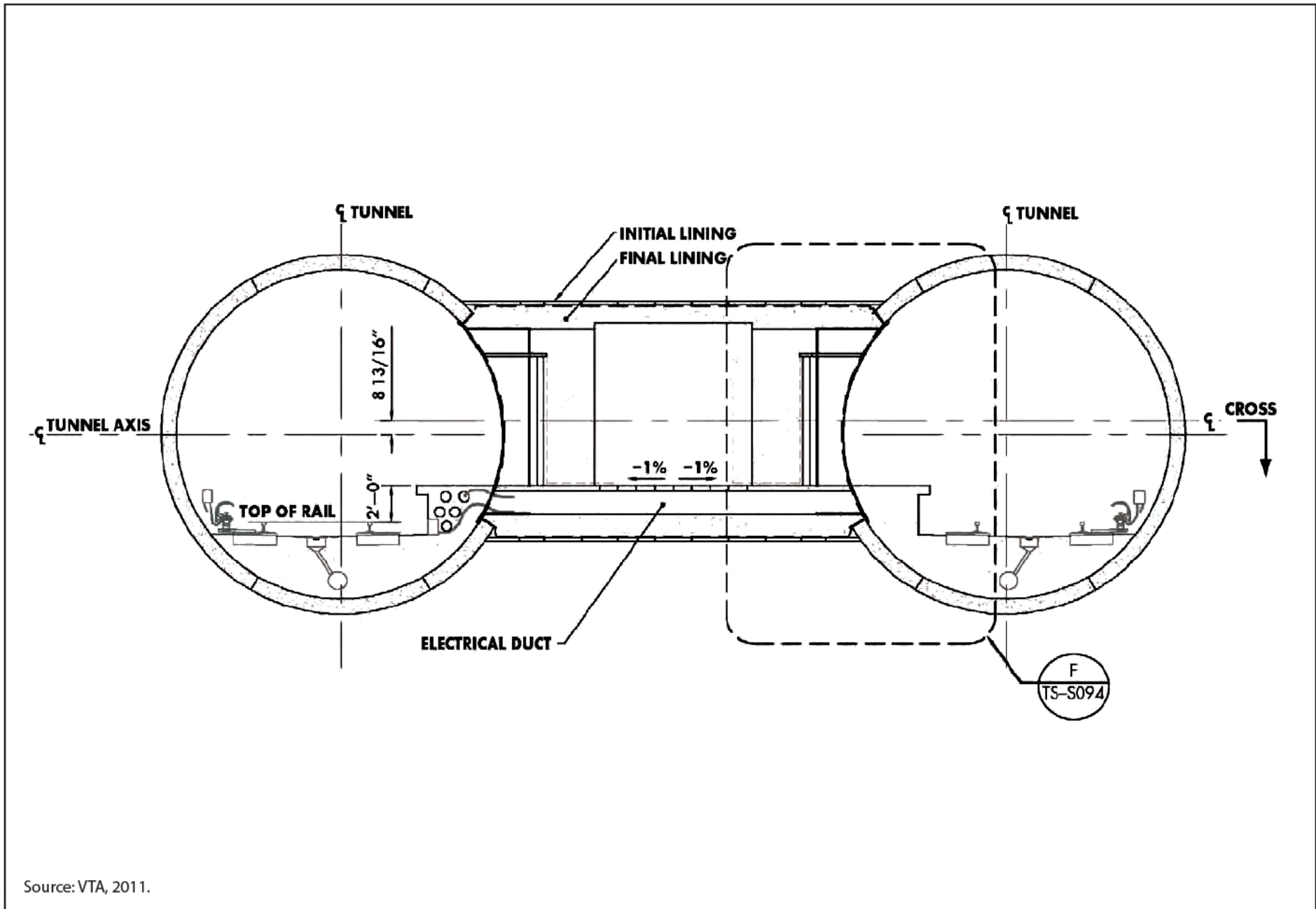

Source: VTA, 2011.

**Figure 5-22**  
**Cross-Passage Connecting the Tunnel Bores**  
 VTA's BART Silicon Valley-Phase II Extension Project

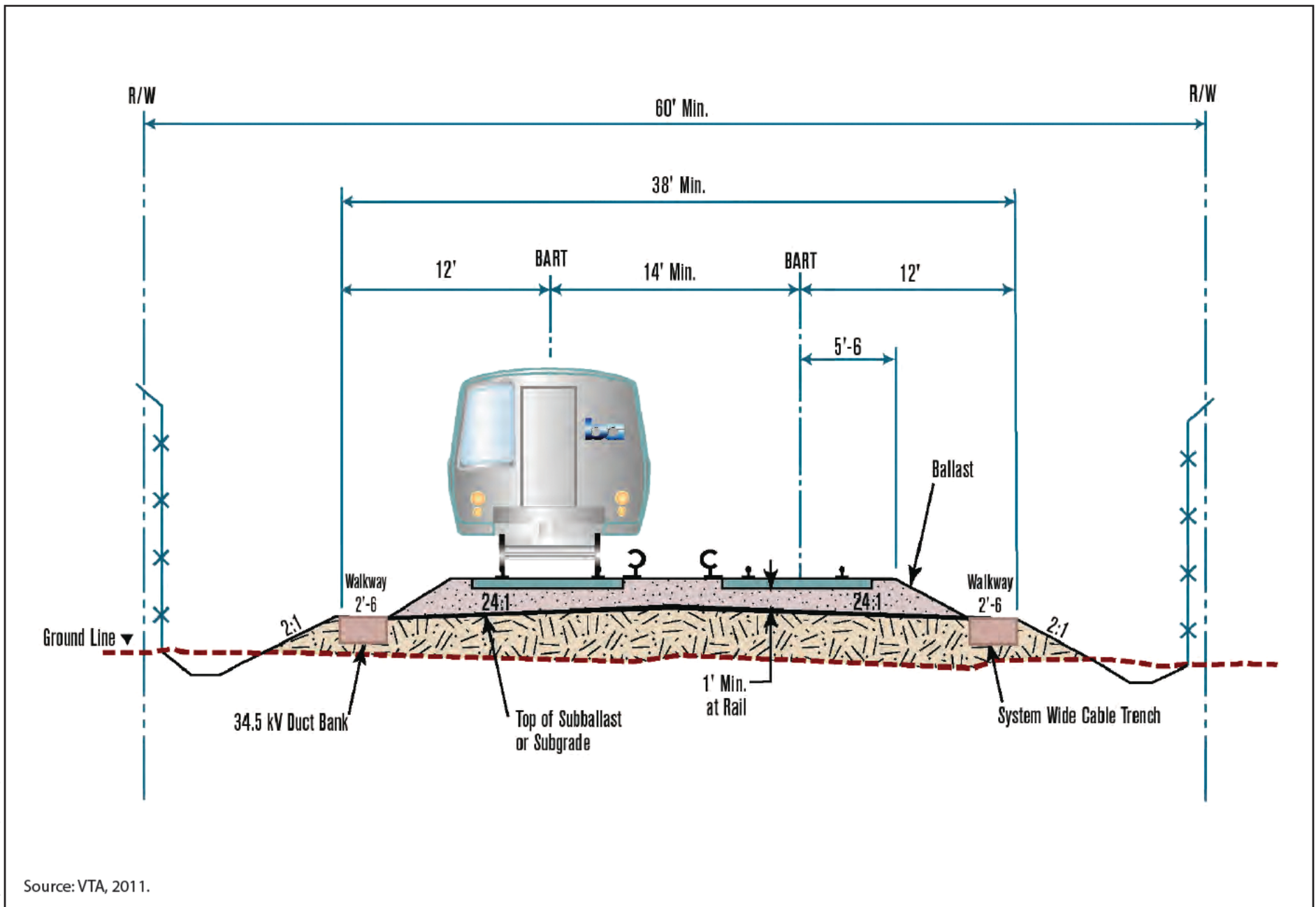

Source: VTA, 2011.

Graphics ... 00332213 (6-20-2016)

**Figure 5-23**  
**At-Grade Guideway**  
 VTA's BART Silicon Valley-Phase II Extension Project



## Retained-Cut Configuration

Under both the Twin-Bore and Single-Bore Options, the segments of the BART Extension alignment that would be in a retained-cut configuration are just north of the East and West Tunnel Portals. Under a retained-cut configuration, the guideway is located below ground within a trench. Concrete retaining walls are constructed on either side of the trench to support the adjacent ground. The guideway is placed either on subgrade or a concrete slab at the bottom of the trench. Figure 5-24 shows a conceptual cross section of a retained-cut construction configuration. The earth excavated from a retained-cut configuration can either be used for embankment onsite (if found to be suitable) or hauled to a disposal site. The water from the dewatering of the excavation area may be placed in settling ponds, “Baker Tanks,” or some other equivalent water containment device to allow suspended solids in the water to settle out. Onsite treatment may be required if the water is contaminated prior to discharge into the storm or sanitary sewer system. Contaminated water that could not be treated onsite would be disposed of offsite consistent with all applicable laws and regulations.

Due to the nature of soft soils, presence of high groundwater, and proximity to adjacent buildings, temporary shoring walls would be needed to support the sides of retained cuts prior to construction of the permanent structures. Several methods can be used for temporary shoring walls, including soil-cement mix walls and slurry diaphragm walls; which are described in Section 5.3.1.7, *Cut-and-Cover Construction*; and steel sheet piles, soldier piles and lagging, and soil nailing, which are briefly described below. These latter three methods are preferred for retained-cut construction where the excavations are shallower than for cut-and-cover construction. One or more methods may be used at a single location depending on site-specific conditions. Depending on the method chosen for the temporary shoring walls and the depth of groundwater, varying degrees of dewatering could be required.

**Steel Sheet Piles.** Steel sheet piles consist of interlocking Z- or U-shaped steel sections that are driven into the ground by either a percussion or vibratory hammer prior to excavation (Figure 5-25). During excavation between the two sheet pile walls, horizontal steel beams are placed along the walls at designated spacing to transmit the soil and groundwater forces to lateral-bracing members. Typically the lateral-bracing members can be either struts composed of steel H-beams or steel pipes that span across the width of the excavation (Figure 5-26) or tieback anchors (described in Section 5.3.1.7, *Cut-and-Cover Construction*). The equipment used to install steel sheet piles typically includes an impact pile driver or vibratory pile driver, material delivery trucks, and a crane.

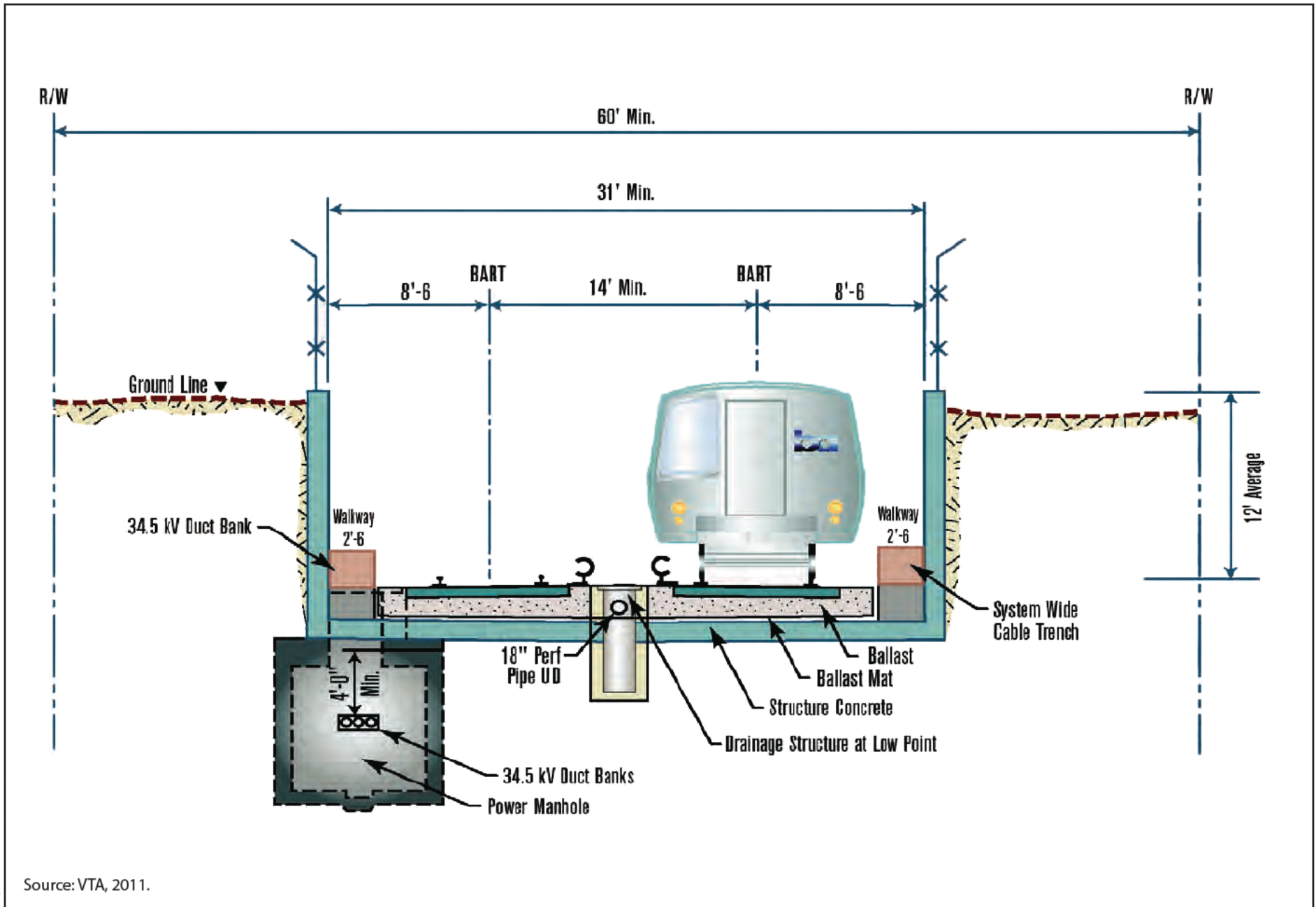

Source: VTA, 2011.

**Figure 5-24**  
**Retained Cut U-Wall**

VTA's BART Silicon Valley-Phase II Extension Project

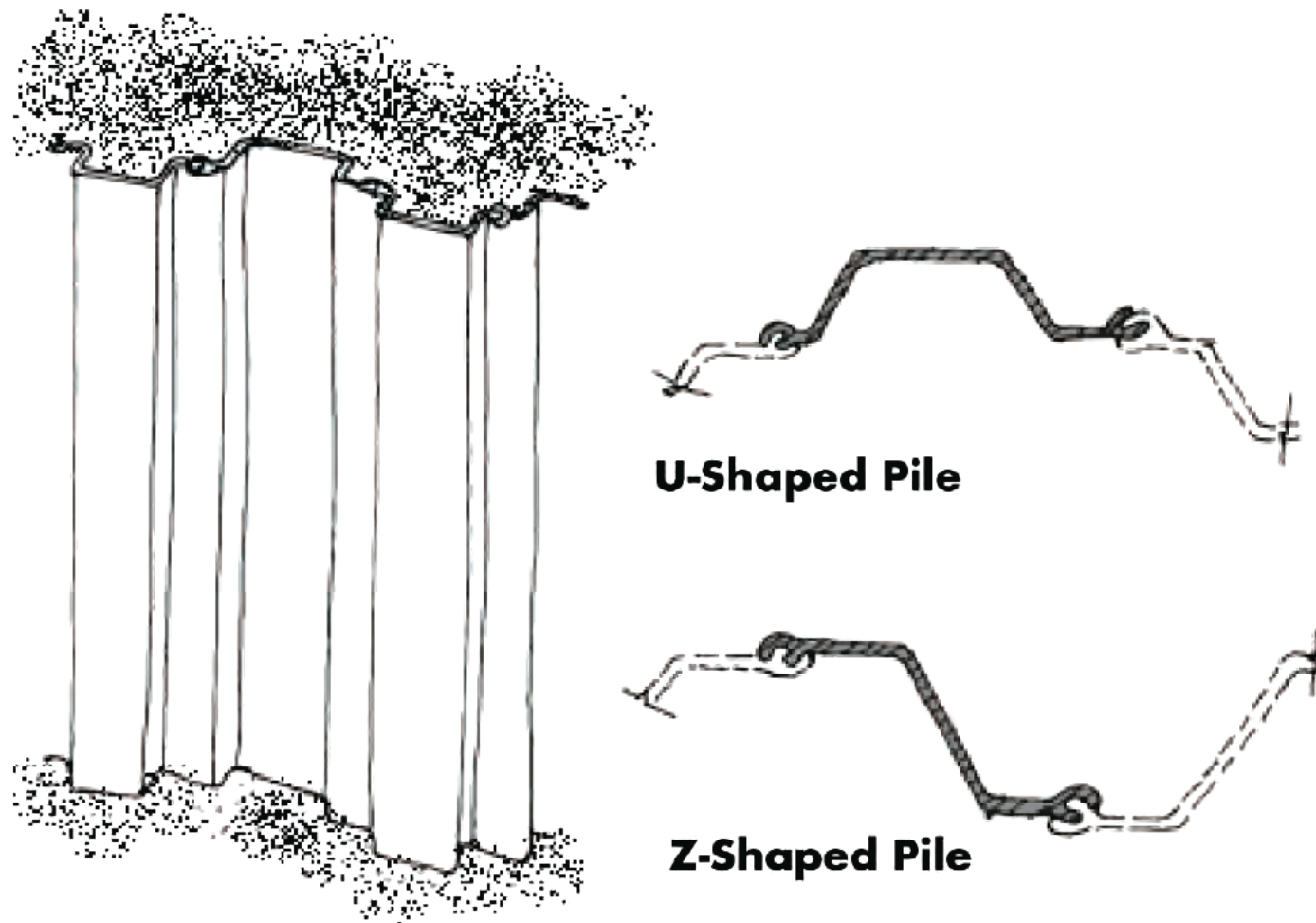

**U-Shaped Pile**

**Z-Shaped Pile**

Graphics ... 00332213 (6-20-2016)

Source: VTA, 2011.

**Figure 5-25**  
**Steel Sheet Piles**  
VTA's BART Silicon Valley-Phase II Extension Project

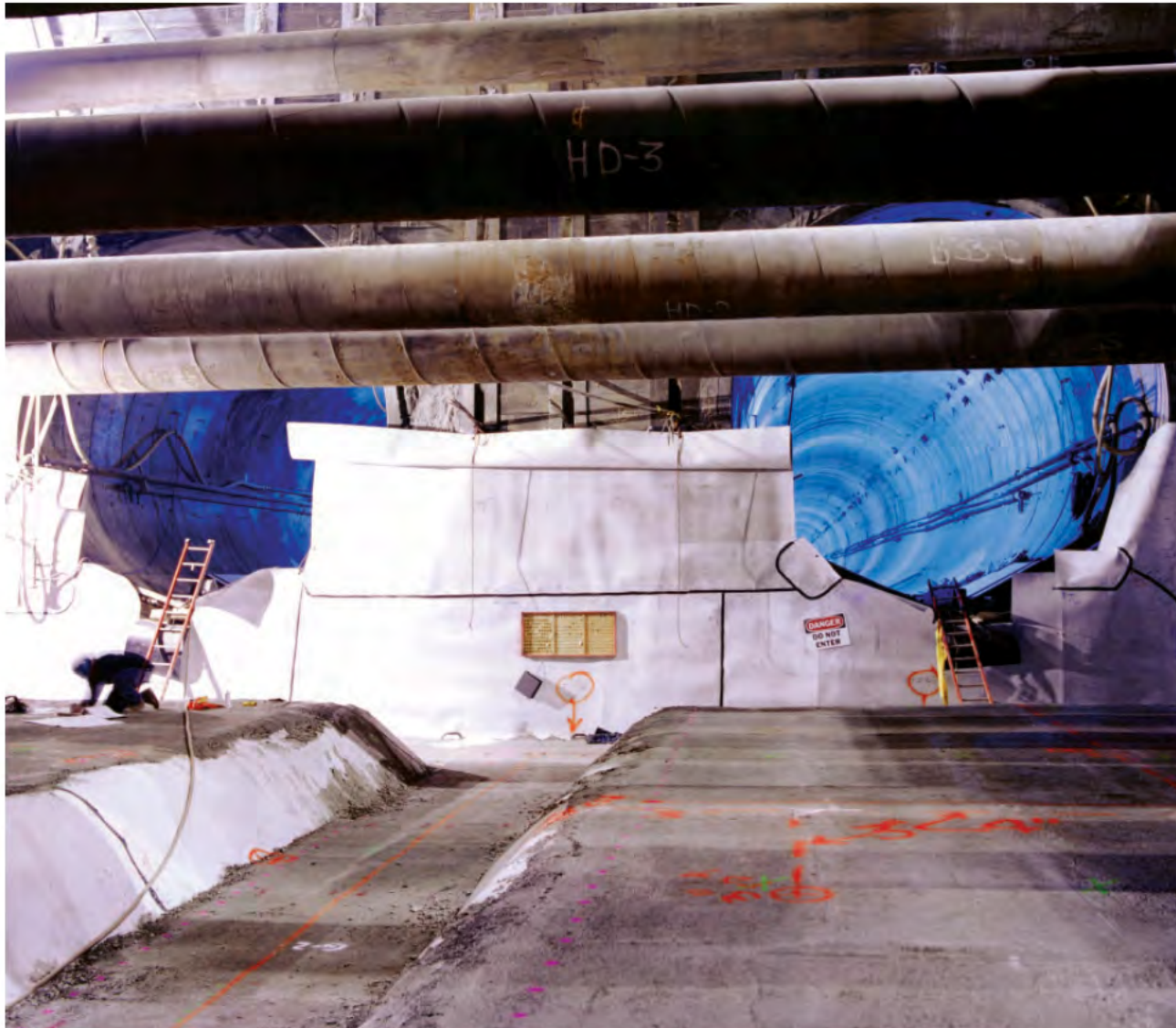

Graphics ... 0033213 (6-20-2016)

Source: VTA, 2011.

**Figure 5-26**  
**Lateral Bracing Members**  
VTA's BART Silicon Valley–Phase II Extension Project



**Soldier Piles and Lagging.** Soldier piles are steel H-beam column sections placed either in predrilled holes, which are then filled with concrete, or driven into the ground using either a percussion or vibratory hammer, at a regular spacing of approximately 4 to 6 feet. Timber or steel planks (“lagging”) are placed between the H-beams as excavation proceeds from the top down. The end result is a wall composed of steel H-beam column sections with timber planks placed horizontally between them (Figure 5-27). Typically the equipment used to install soldier steel piles and lagging includes an impact pile driver or vibratory pile driver, auger drill rig, material delivery trucks, crane, and spoils hauling trucks for material removed from the predrilled holes.

**Soil Nailing.** Soil nailing is a method of reinforcing a soil mass so that the soil will act as a stable unit. Soil nails consist of reinforcing steel bars or other bar sections inserted in small-diameter holes that are drilled or augered into the exposed sides of an excavation as the excavation proceeds from the top down. The bars are grouted in place along their entire length. After soil nails are installed, a shotcrete facing approximately 4 inches thick is applied to the excavation face (Figure 5-28). Shotcrete is a concrete mixture that is pneumatically blown under pressure onto a mesh of reinforcement connected to the soil nails. The sequence of excavation, nail installation, and shotcreting is repeated.

## **Track Construction**

The BART tracks would be installed with either ballasted or direct fixation (DF) track. Ballasted track construction begins with a layer of compacted material similar to that used for roadways. Ballast, rails, and ties are installed next using specialized equipment. There are a variety of methods used to construct DF track. The BART standard is through the use of resilient ties. Resilient ties are precast concrete blocks embedded in encasement concrete, with the rails fastened to each resilient tie. To provide for power to the electric third rail, conduits encased in concrete are laid in a trench and covered with earth backfill. The actual power cables are installed during construction of the system-wide elements of the guideway.

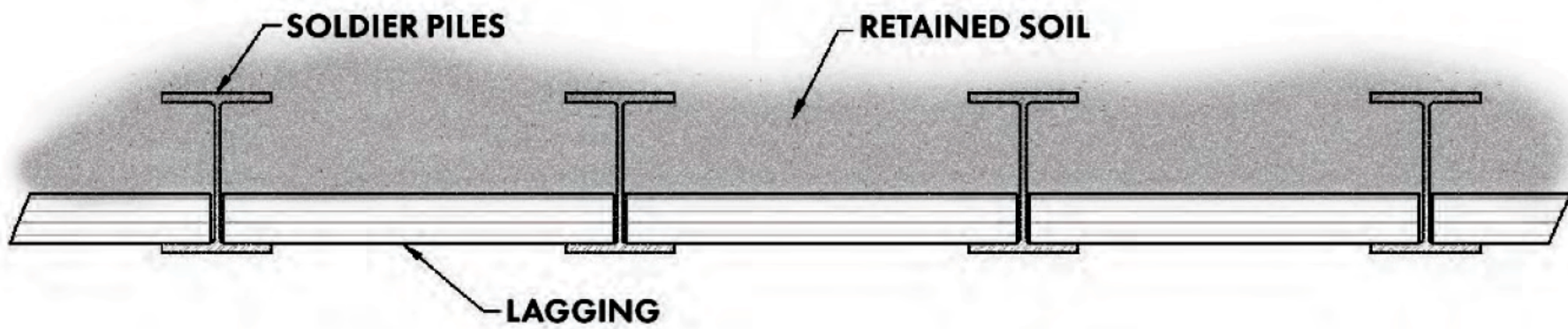

Graphics ... 00332.13 (6-20-2016)

Source: VTA, 2011.

**Figure 5-27**  
**Soldier Piles and Lagging**  
VTA's BART Silicon Valley-Phase II Extension Project

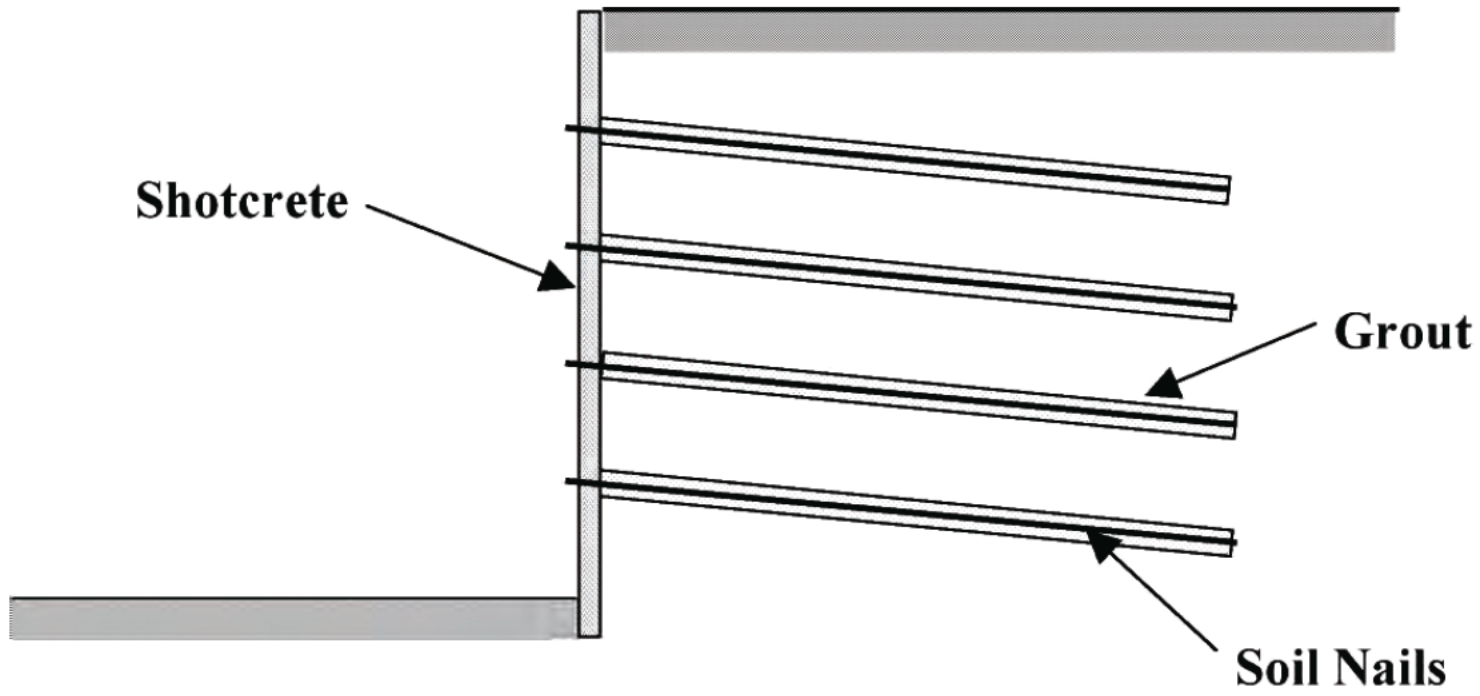

Graphics ... 00.332.13 (6-20-2016)

Source: VTA, 2011.

**Figure 5-28**  
**Solid Nail Wall**  
VTA's BART Silicon Valley-Phase II Extension Project

### 5.3.1.7 Cut-and-Cover Construction

The cut-and-cover construction method includes excavation from the street or ground level down to the base of excavation, construction of the underground facility, then installation of the top of the underground facility, and restoring the surface above the facility. Under the Twin-Bore Option, the two tunnel portals, three underground stations (Alum Rock/28<sup>th</sup> Street, Downtown San Jose [East and West Options], and Diridon [South and North Options]), one underground crossover, and two mid-tunnel ventilation structures would be constructed by a cut-and-cover construction method. Under the Single-Bore Option, the two tunnel portals, two mid-tunnel ventilation structures, and off-street portions of the three underground stations (Alum Rock/28<sup>th</sup> Street, Downtown San Jose [East and West Options], and Diridon [South and North Options]) would be constructed via a cut-and-cover method. This would include station entrances, escalators, elevators, and ventilation facilities, among other elements of the station facilities but not the station boarding and alighting platforms. If a large cut-and-cover excavation is located within a street, a temporary deck would be installed to allow activity to resume on the street while the remaining excavation and cut-and-cover construction continues underground (Figures 29 and 30).

Material excavated from the street level or below the temporary deck would be transported to a disposal site permitted to accept the material.

Equipment typically used for excavation and installation of temporary decking includes crawler dozer/loader, rubber-tired loader/bobcat, pavement breaker, excavator/backhoe, conveyer system, truck, crane, generator/compressor, water pump, forklift, and haul trucks.

Utilities that would not require temporary or permanent relocation would be uncovered during the early stages of excavation. These buried utilities, with the possible exception of sewers, are generally found within 10 feet of the street surface (e.g., telephone, traffic, electric). These utilities would be reinforced, if necessary, and supported during construction by hanging from support beams spanning across the excavation (Figure 5-31).





Graphics ... 00332.13 (6-20-2016)

Source: VTA, 2011.

**Figure 5-29**  
**Temporary Deck Installation**  
VTA's BART Silicon Valley–Phase II Extension Project

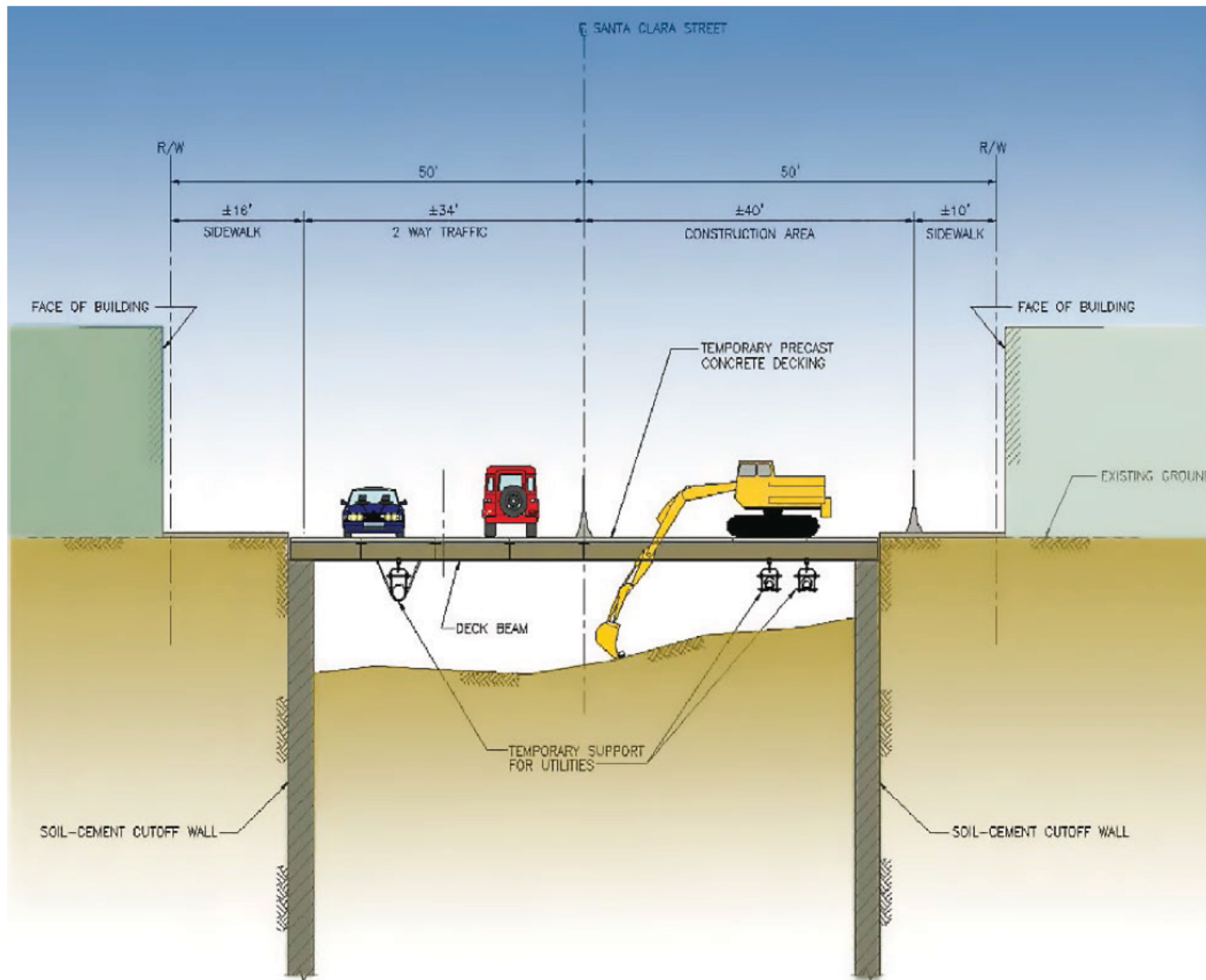

Source: VTA, 2011.

**Figure 5-30**  
**Ongoing Excavation After Temporary Deck Installation**  
 VTA's BART Silicon Valley-Phase II Extension Project





Graphics ... 0033213 (6-20-2016)

Source: VTA, 2011.

**Figure 5-31**  
**Temporary Utility Support in an Excavation**  
VTA's BART Silicon Valley–Phase II Extension Project

## **Construction Shoring/Support of Excavation for Deep Cut-and-Cover Construction**

Due to the nature of soft soils, presence of high groundwater, and proximity to adjacent buildings particularly in Downtown San Jose, temporary shoring walls would be installed to support the sides of deep cut-and-cover excavations. Several methods can be used for the temporary shoring of excavation walls, including soil-cement mix wall and slurry diaphragm wall (described below). Given the soil conditions within the cut-and-cover areas, these two methods are preferred for cut-and-cover construction where the excavations are deeper than retained-cut construction. Other methods may be used for shallower excavations and are described above under *Retained-Cut Configuration*. One or more methods may be used at a single location depending on site-specific conditions. Depending on the method chosen for the temporary shoring walls and the depth of groundwater, varying degrees of dewatering may be required.

Support for the walls is typically provided through the use of tiebacks and/or internal bracing. Tieback anchors (Figure 5-32) are long metal rods or bundled tendons drilled and grouted into the ground to brace construction support walls and adjacent property and/or structures during excavation of underground facilities. Tiebacks may remain in the ground after completion of construction. The tiebacks are estimated to be up to 110 feet in length with up to 50 feet bonded or secured in place. Tiebacks are typically spaced at 4 to 6 feet on center horizontally and 5 to 8 feet on center vertically. Tieback installation could start at approximately 3 feet below grade. Tiebacks are generally installed at an incline of 15 degrees from the horizontal.

Alternatively, internal bracing consisting of large metal struts and other mechanisms may be used to support the construction support walls, which would be sequentially removed after construction of the station or other cut-and-cover structures.



**Shoring  
Wall**

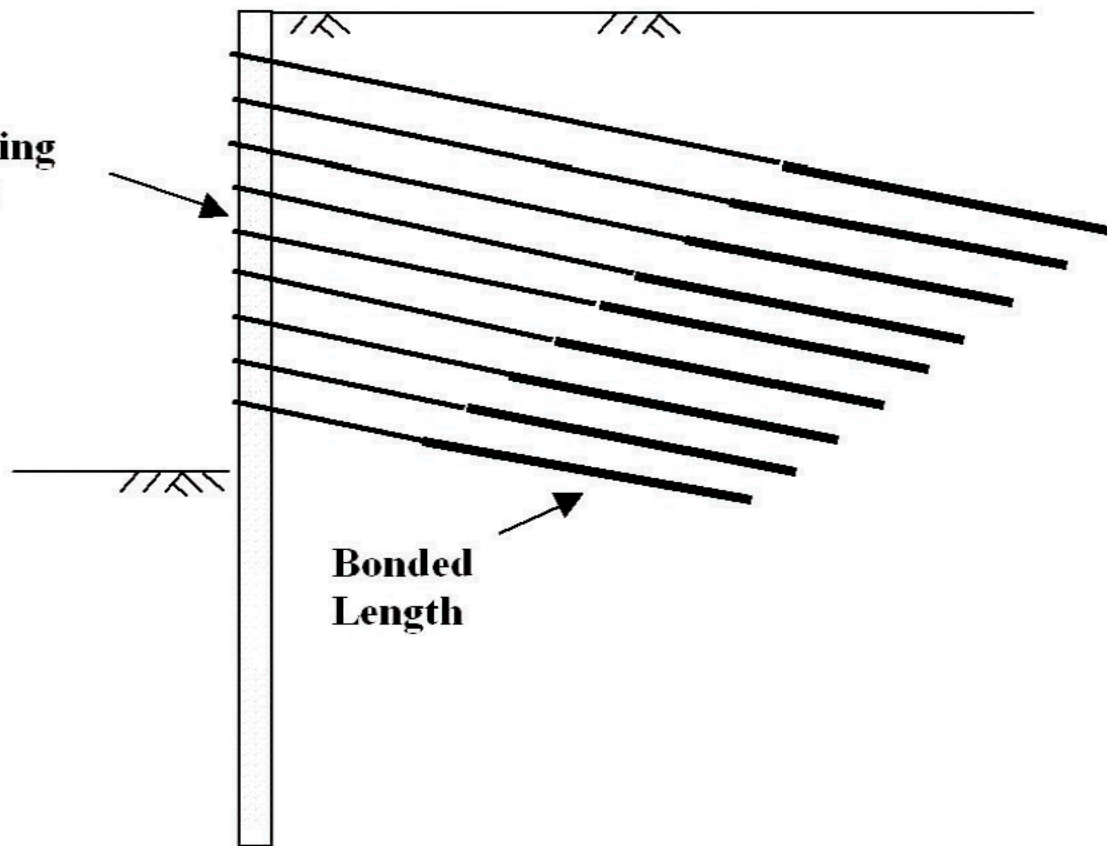

**Bonded  
Length**

**Figure 5-32**  
**Basic Components of a Tieback Anchor**  
VTA's BART Silicon Valley-Phase II Extension Project

**Soil-Cement Mix Wall.** A soil-cement mix wall is typically constructed deep enough to penetrate into an impermeable soil layer below the base of an excavation so that groundwater seepage is minimized. This type of wall can be constructed in several ways.

- One method for constructing a soil-cement mix wall as temporary shoring is Deep Soil Mix (DSM). This method involves mixing cement with in-situ soil using an auger rig (Figure 5-33). The augers are fitted with rotating paddles that mix the soil with cement as the augers advance into the ground and as they are pulled out. The result is a continuous and nearly waterproof wall made up of individual overlapping columns of soil mixed with cement. Every other column of the soil-cement mix is then structurally reinforced with steel beams that are inserted into the soil-cement mixture before the mixture sets and hardens (Figure 5-34).
- Another method for constructing a soil-cement mix wall is trench remixing and deep-wall method (TRD). Instead of drilling individual columns that overlap each other as in the DSM method, this method involves the use of a single hydraulic-driven cutting and mixing arm that resembles a huge vertical chain saw. As it digs a continuous trench into the ground, the arm mixes cement with in-situ soil in a continuous trench to construct the soil-cement mix wall into which vertical steel beams are then inserted (Figure 5-35).

**Slurry Diaphragm Wall.** Another method to minimize groundwater seepage is a slurry diaphragm wall. This wall can be constructed as a combined temporary and permanent wall, resulting in a single permanent wall. This method involves excavating short sections of deep trenches in the ground where the wall is to be located, placing steel reinforcement cages into the trenches, and then filling them with concrete (Figure 5-36). To stabilize the trenches, bentonite slurry is placed in the trench during excavation. This slurry has the ability to support the walls of the trench until the trench can be fully excavated and the concrete poured. The bentonite slurry is then displaced during concrete placement and can be reused for subsequent sections of slurry wall. The slurry diaphragm wall method produces a concrete wall that can serve as the permanent wall. The equipment used to install slurry diaphragm walls typically includes a crane with a specialized excavation attachment; a crane to lift very large steel reinforcement cages in place; a backhoe, dump trucks, bentonite slurry mixers/storage tanks, a pump and pipe network for bentonite slurry; concrete mixer trucks; and similar large construction equipment.

After installation of the soil-cement or slurry diaphragm walls, excavation and installation of the support system would begin and would continue until the excavation is deep enough for the construction of the base slab. The excavation would proceed in discrete stages, with the soil cement or slurry diaphragm walls supported at intermediate locations as the excavation proceeds downward.



Source: VTA, 2011.

**Figure 5-33**  
**Deep Soil Mix and Auger Rig Installation**  
VTA's BART Silicon Valley–Phase II Extension Project





Graphics ... 0033213 (6-20-2016)

Source: VTA, 2011.

**Figure 5-34**  
**Deep Soil Mix and Steel Soldier Piles**  
VTA's BART Silicon Valley-Phase II Extension Project



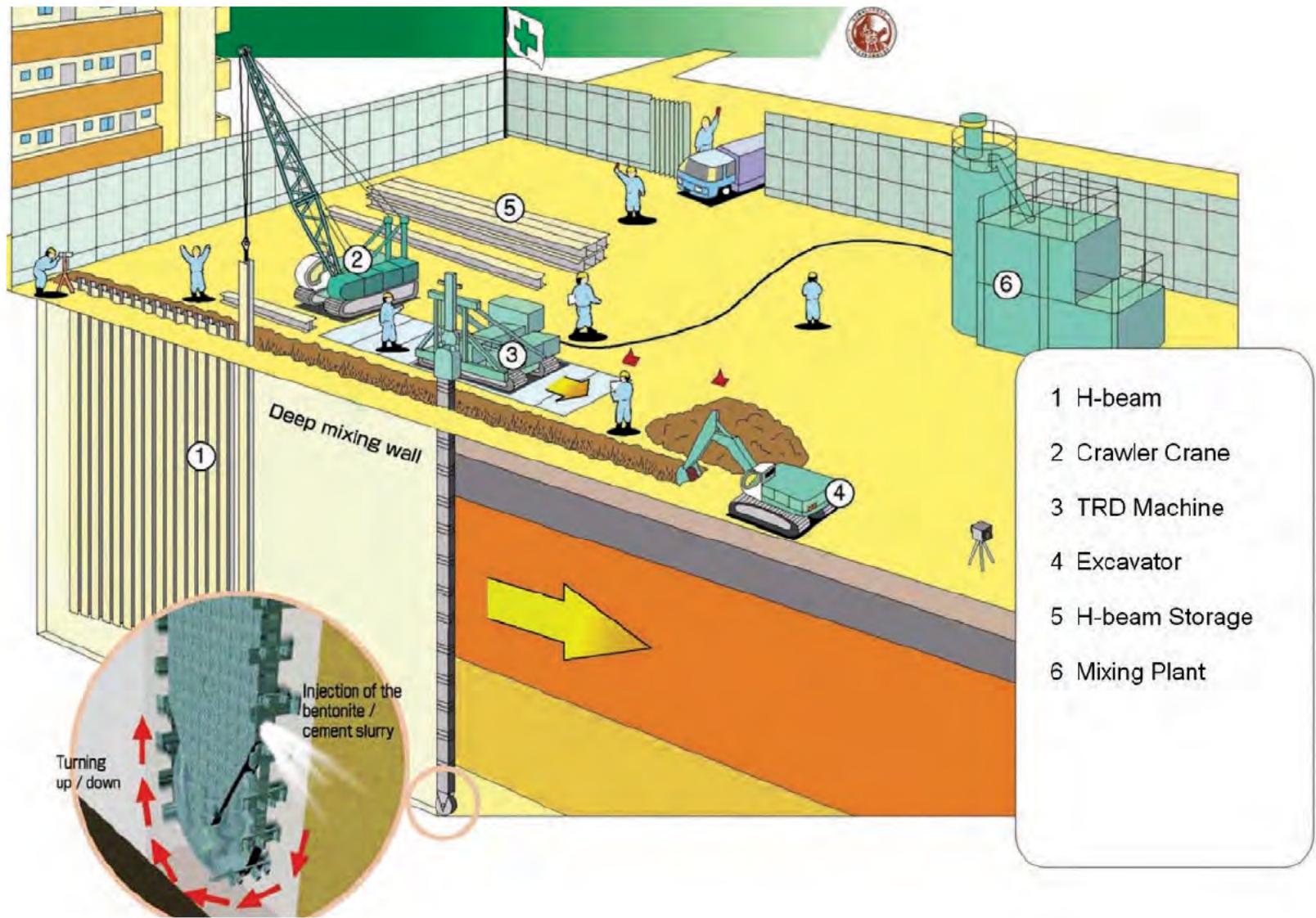

Source: VTA, 2011.

**Figure 5-35**  
**Trench Remixing and Deep-Wall Method (TRD)**  
 VTA's BART Silicon Valley-Phase II Extension Project

In general, slurry wall construction consists of four major steps:

1. Guide wall construction
2. Panel excavation in slurry trench
3. Rebar cage placement
4. Concrete placement in slurry trench

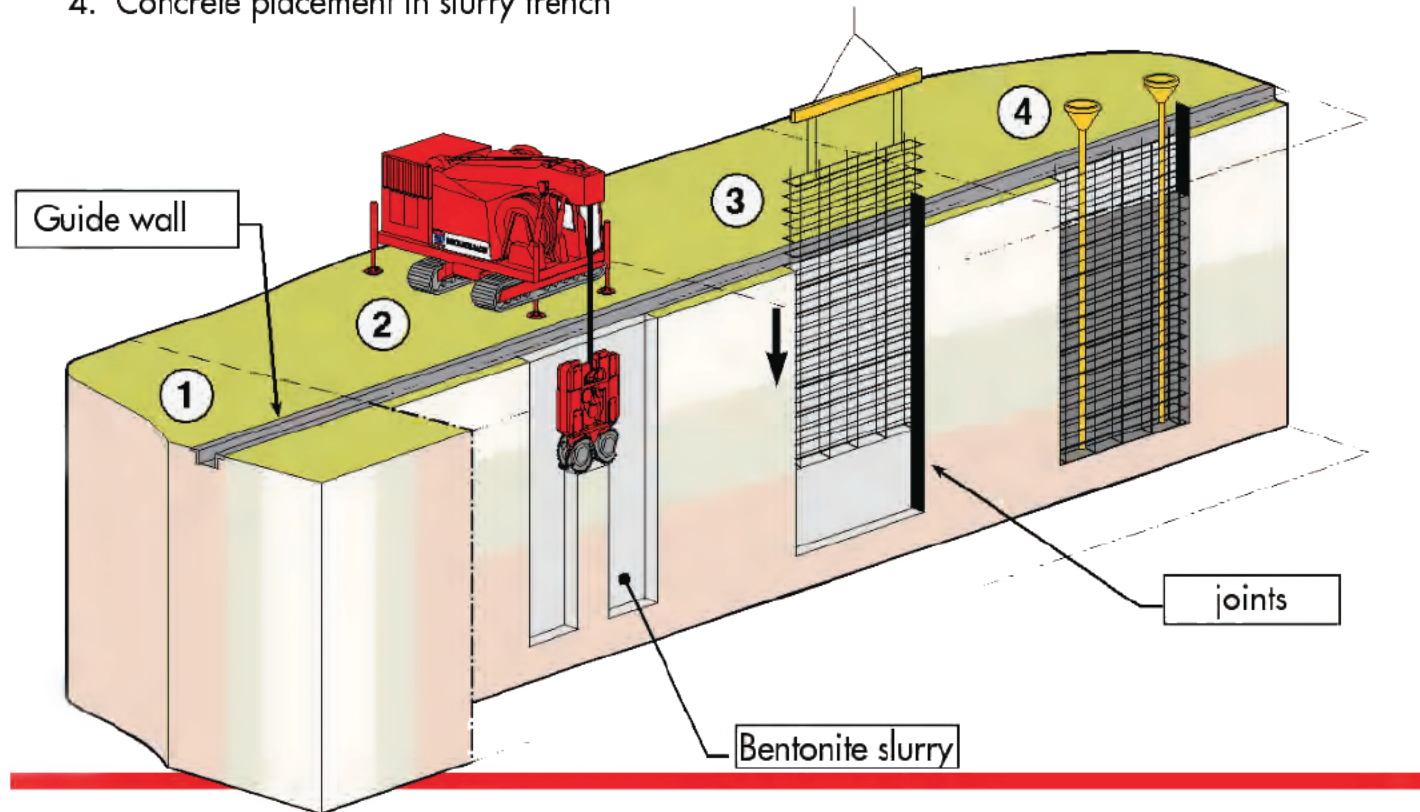

**Figure 5-36**  
**Construction of a Diaphragm Slurry Wall**  
VTA's BART Silicon Valley–Phase II Extension Project

If the temporary support system is used, permanent sidewalls are constructed. Intermediate slabs and the roof slab are then installed. After the underground structure has been completed and the roof slab is allowed to cure for a specified period, backfilling can begin. During backfilling operations, any temporarily relocated utilities are restored to their permanent locations. When the backfill reaches the underside of the temporary deck, the permanent street is constructed. With the restoration of utilities, roadway pavement, and vehicular traffic, the surface work on the structure is completed, and any other activity involving station finishes, equipment installations, and so forth continues beneath the surface with little, if any, disruption to the street level.

### **5.3.1.8 Mined-Station Construction**

Mined-station construction methodology is the construction of underground facilities with reduced or minimal disturbance to the surface over the underground facility. This construction technique was evaluated as an alternative to the cut-and-cover construction methodology proposed for construction of the three underground stations for the Twin-Bore Option. Unlike the cut-and-cover construction method, which would excavate the stations from the surface down to the base of the excavation, the mined-station method would excavate the stations from within the bored tunnel or from other off-street, underground locations to attempt to avoid the disruption of traffic operations and restriction of access to businesses on the surface above the construction site. As mentioned below, due to unstable soils within downtown San Jose, mining of the underground stations would require extensive ground treatment to stabilize soil prior to mining of the station in sections.

The feasibility of constructing mined stations as part of the BART Extension to San Jose was first assessed by URS (2003), with a team consisting of experts in the disciplines of geotechnical and tunnel engineering and underground construction. A total of 27 case studies were identified that involved mined underground stations in metropolitan areas, 23 of which were successful due to favorable subsurface conditions for mining (i.e., rock, stiff-hard clays, or dense granular soils above the water table). The remaining 4 case studies identified undesirable subsurface conditions (i.e., soft ground with high groundwater table), much like Downtown San Jose, which resulted in large ground deformations, damage to underground utilities, and disruption to local businesses. Mining would be considerably riskier than cut-and-cover construction, prolonging the project schedule by 6 to 9 months. Mining would also involve a certain level of surface disruption and undesirable impacts on the public. URS concluded that mined station construction would not provide significant benefits in contrast to a cut-and-cover construction method.

In 2012, VTA reassessed the feasibility of a mined station and whether the conclusions drawn by URS (2003) were still relevant based on technological and material advances in the tunneling industry (HMM/Bechtel 2012). The review reiterated that the potential disadvantages of mining include, but are not limited to, contamination issues due to grout slurry leakage, muck disposal, varied effectiveness for fine-grained and coarse-grained soil types, required surface road closures, and the potential of near-surface ground swelling due

to the soil treatments required to make mining possible. Because of the lack of soil stability and high groundwater table in the Downtown area, ground improvement would be required. This could be accomplished by either jet grouting or deep soil mix methods. Jet grouting solidifies the soil by injecting cement slurry under high pressure. The deep soil mix method introduces cementitious binders to create greater strength and reduce permeability. Both of these methods would require heavy equipment operating along Santa Clara Street with road closures.

The feasibility study states that the jet-grouting mined station option is estimated to cost approximately \$140 million more than the cut-and-cover construction option. The HMM/Bechtel analysis recommended that a greater contingency multiplier be applied to the estimate for mined stations (30 percent versus 15 percent for cut-and-cover construction) due to the greater design and construction risks and uncertainties. Therefore, although mining has been considered as an option, the uncertainties and associated potential damage to nearby utilities, disruption to local businesses, and impacts on cost and schedule make mining unfeasible. The feasibility study recommends cut-and-cover construction of the Downtown San Jose Station, as this method is better-suited for construction of this station within the geotechnical conditions in the Downtown San Jose area.

### **5.3.2 Aboveground Stations and Ancillary Facilities Construction**

The construction of aboveground facilities would include the aboveground Santa Clara Station, station entrances, system facilities, parking structures, bus transit centers, new utilities, roadway and sidewalk improvements, drainage improvements, outdoor lighting, and landscaping.

Construction of aboveground structures would include demolition and relocation or protection of utilities. Site preparation, such as grading and paving, would follow, and buildings or structures would be constructed using typical construction equipment.

### **5.3.3 Systems Installation**

Systems and related facilities include traction power substations, high voltage substations, switching stations, gap breaker stations, auxiliary power substations, emergency ventilation facilities, train control buildings and rooms, other communication facilities such as emergency telephone systems, and associated equipment such as cables, conduits, and wires. BART-furnished equipment such as automatic fare collection, destination signs, and other station communications and computer-related systems are also included. In general, construction of these facilities involves manufacturing, factory testing, delivery, installation, and field-testing.

Many of the stand-alone structures that house the equipment are within station areas and, for the Single-Bore Option, within the tunnel. Some of the facilities are integrated into the stations, whether aboveground or within the ancillary areas of underground stations and, for



the Single-Bore Option, in the tunnel adjacent to the platforms. Facilities located aboveground would be constructed using methodology typical for moderately sized sites and structures including demolition, site preparation, and building construction. Facilities located underground at the Alum Rock/28<sup>th</sup> Street, Downtown San Jose, and Diridon Stations and two mid-tunnel ventilation structures would be constructed as part of the underground structures.

Installation of some systems and related facilities would extend beyond the immediate construction sites and continue along the guideway, such as installation of electrical cabling in duct banks beside the BART tracks and other electrical devices at nearby locations.

Systems and related facilities would be tested incrementally as the individual sites are completed and at completion of construction. This effort is generally contained within the structures or rooms that house the equipment.

### **5.3.4 Newhall Maintenance and Storage Facilities Construction**

Construction of the Newhall Maintenance Facility would include a number of activities, starting with street and building demolition and site preparation. Utilities would be protected, removed, or relocated. Ground improvements may include the process of ground compaction where future buildings and other facilities would be located to reduce potential settlement. Temporary construction fencing would be installed to secure the site and storage of construction materials. Foundations for the buildings would be constructed. Underground system conduits, duct-banks, new incoming services to all buildings, sub-drains, and storm drain piping would be installed. New or widened roadways, building shells and finishes, and other facilities would be constructed. The BART mainline, maintenance, storage, and tail tracks would be installed to handle up to 200 BART cars. Permanent perimeter fencing, gates, and lighting would be installed. Testing and start-up of elements associated with the Newhall Maintenance Facility, including the revenue vehicle maintenance shop, maintenance and engineering shops, non-revenue vehicle maintenance shop, storage facilities, mainline tracks, and tail tracks, would be performed.

### **5.3.5 Revenue Vehicle Procurement**

BART is in the process of procuring BART revenue cars to replace older BART cars and accommodate long-term demand. VTA is purchasing 48 BART cars as part of this procurement to serve the BART Extension. The 48 BART cars would meet the projected 2035 Forecast Year ridership demand. The new revenue vehicles would be delivered and tested for acceptance over a period of time at designated BART locations where simulated operations for both trains and individual cars would be performed. These tests would verify that the new vehicles meet all requirements for revenue service.

## **5.4 Testing and Commissioning**

### **5.4.1 Systems Integration Testing and Commissioning**

The systems integration testing and commissioning phase is the extension of the testing activities as previously described and includes a level of testing that is beyond individual sites and subsystems in order to test the completed BART Extension. During this phase, the interconnections and functioning of equipment that operate throughout the alignment would be verified, and operating procedures, personnel training, and maintenance would be reviewed. As such, a major portion of this activity would be the testing of equipment and functions that involve multiple sites including the Operations Control Center for the entire BART system. This is sometimes termed Systems Integration Testing and Commissioning (shown on Figure 5-1 as a separate activity). This phase also includes the extensive training of all staff in the operation and maintenance of the system.

Final Safety Certification is received when systems are operating as intended and all command and control subsystems and procedures are adequate to provide the intended services. Both normal operations and a series of abnormal (failure) conditions are simulated to reach a level of confidence that the system is safe for revenue service. This phase is the final step in the construction program that leads, when successfully completed, to revenue service.

### **5.4.2 Revenue Service Phase**

The revenue service phase involves completing pre-revenue testing, staff training in operations and maintenance of the new system, and safety certified in concert with the state safety oversight agency

## **5.5 Impacts from Construction of the BART Extension**

### **5.5.1 Construction Outreach and Management Plan**

Construction of the BART Extension would temporarily affect nearby businesses and residences along the alignment, especially in Downtown San Jose, which has constraints on available space for construction. These effects would entail increase in noise from construction activities, increase in fugitive dust, visual impacts from the presence of construction equipment and personnel, diminished pedestrian and vehicular access to businesses and residents, detours for pedestrians and vehicles (including buses), and potential utility disruptions. Please see the detailed discussion of construction impacts by resource area below.

Prior to construction, a coordinated outreach effort would be implemented to inform local businesses and residents regarding construction activities and efforts in order to minimize

impacts during construction. Additionally, the outreach effort would provide an avenue for the receiving of concerns, comments, and questions from the public. The following mitigation measure will be implemented to address construction issues and inform the public and other stakeholders of the construction schedule and associated activities. These measures would be implemented for both the Twin-Bore and Single-Bore Options.

### **Mitigation Measure TRA-CNST-A: Develop and Implement a Construction Education and Outreach Plan**

A Construction Education and Outreach Plan (CEOP) will be developed by VTA to foster communication between VTA, various municipalities, and the public during the construction phase. The plan will be implemented to coordinate construction activities with existing business operations and other development projects and to establish a process that will adequately address the concerns of businesses and their customers, property owners, residents, and commuters. Critical components of this plan will include but are not limited to the following public outreach strategies using a variety of media opportunities.

- Frequently update stakeholder groups, business organizations, and municipalities.
- Conduct public workshops and meetings with community members.
- Distribute project information and advanced construction notification via flyers, emails, mailers, and face-to-face visits.
- Continuously share project information and contacts via posts to the website.
- Maintain media relations (i.e., news releases, news articles, and interviews).
- Maintain onsite outreach coordinator/personnel and 24-hour hotline.
- Work with property owners and business owners in the station areas to maintain access to businesses during construction including enhanced signage.
- Develop and distribute promotional and marketing materials to encourage customers to shop at businesses during construction.

Throughout development and implementation, the education and outreach activities will be comprehensive, seeking widespread involvement; proactive, with efforts geared toward obtaining input, as well as disseminating information; responsive to various needs, including multiple languages and alternative formats; and timely, accurate, and results-oriented.

### **Mitigation Measure TRA-CNST-B: Develop and Implement a Construction Transportation Management Plan**

A Transportation Management Plan will be developed by VTA to coordinate vehicle, bike, pedestrian, and public transportation circulation during construction. Critical components of the plan are as follows.



- VTA will coordinate with transit providers as necessary to ensure that appropriate measures are taken to re-route bus routes and to relocate bus stops during construction.
- Bus bridge service will be provided during the temporary closure of light rail service (Downtown San Jose Station West Option only).
- Pedestrians and bicyclists will be provided with safe travel corridors within and through construction areas, or detour routes will be set up with wayfinding signage.
- For vehicular traffic, as part of the CEOP, VTA will inform the Cities of San Jose and Santa Clara staff, media, and public about upcoming construction activities, schedules, roadway closures, and detours within the station areas and system facility locations. In addition, VTA will work with the cities to modify green times at key intersections during construction; set up event timers at key intersections for time of day when closures are planned; modify timing to allow longer gap and maximum times for detour movements at key intersections; provide flag control or temporary signalization at un-signalized intersections; and provide early signage of potential construction delays for motorists to choose alternate routes.
- VTA will work with agency staff and the SAP Center to develop an access and circulation plan during construction to minimize impacts on pedestrians and bicyclists traveling through Diridon Station and/or accessing SAP Center (Diridon Station only).
- VTA will work with the California Department of Transportation (Caltrans), the Cities of San Jose and Santa Clara, the Downtown Business Association, business owners, and key stakeholders to develop this Transportation Management Plan to minimize adverse effects from construction. As part of the plan, traffic and pedestrian detours, alternate access, signage, and public outreach will be implemented along with special scheduling to offset the adverse effects of street or lane closure.

### **Mitigation Measure TRA-CNST-C: Develop and Implement a Parking Management Plan**

A Parking Management Plan will be developed by VTA to coordinate parking during construction. Critical components of the plan are as follows.

- VTA will inform the Cities of San Jose and Santa Clara, the Downtown San Jose Business Association, business owners, residents, and key stakeholders (such as the SAP Center) regarding lane and road closures that would affect parking. VTA will work with the cities to minimize disruptions to parking.
- Construction staging areas will be available for public parking if not required for construction activities.

### **Mitigation Measure TRA-CNST-D: Coordinate with Fire and Police Services during Construction**

As local emergency service routes and response times could be affected by construction activities, VTA will coordinate with local fire and police services to minimize this impact. Critical components of coordination are as follows.

- VTA will inform that the local fire and police departments of the construction schedule, and potential lane and road closures.
- VTA will work with emergency providers to ensure emergency access to residents and businesses.
- VTA will work with the local fire and police departments on the detour routes.
- VTA will provide road signage for detours and provide manual traffic control on detour routes as necessary.

## **5.5.2 Transportation**

The discussion that follows describes construction-related transportation impacts due to the BART Extension, beginning in the east near the connection to the Phase I Project terminus and ending in the west at the Santa Clara Station. The Twin-Bore Option tunnel construction involves cut-and-cover construction of the Alum Rock/28<sup>th</sup> Street, Downtown San Jose (East or West Option), and Diridon (South or North Option) Stations and the downtown crossover. As such, construction transportation impacts for the Twin-Bore Option are far greater than for the Single-Bore Option tunnel construction where the three underground stations and the downtown crossover would be constructed underground by TBM. In addition, the cross passages for the Twin-Bore Option would require ground treatment from aboveground, unlike the Single-Bore Option where the cross passages would be within the tunnel. Therefore, the discussion that follows focuses on the Twin-Bore Option tunnel construction impacts. The differences, if any, when compared with Single-Bore Option construction are highlighted at the end of each section.

### **5.5.2.1 Connection to Phase I Berryessa Extension**

#### **Construction Impacts on BART Service**

The BART Extension would construct the connection of the new Phase II tracks to the southern terminus of the Phase I Project. Construction of this connection would not disrupt existing BART revenue service as the connection occurs in the BART vehicle storage area. Therefore, construction would not adversely affect BART service, and no mitigation is required.

## 5.5.2.2 Cross Passages

### Vehicular Traffic

Cross passages would be located within the tunnel of the Twin-Bore Option between the eastern and western tunnel portals to provide emergency evacuation access between the two bored tunnels. Construction of the cross passages would require temporary lane closures at some locations (i.e., reduction of one lane in each direction) while construction crews inject the soils with stabilizing materials prior to underground excavation of the cross passages. This would result in travel delays through these locations, potentially resulting in an adverse effect. However, after implementation of Mitigation Measure TRA-CNST-A and Mitigation Measure TRA-CNST-B, this impact would be not adverse.

The Single-Bore Option tunnel cross passages would be constructed within the tunnel and would not require additional aboveground excavations. Therefore, there would be no traffic impacts with this option, and no mitigation is required.

## 5.5.2.3 Alum Rock/28<sup>th</sup> Street Station

### Transit

No light rail service is provided at or near the Alum Rock/28<sup>th</sup> Street Station area; therefore, construction of Alum Rock/28<sup>th</sup> Street Station would not affect light rail service, and no mitigation is required.

There are no existing bus routes on 28<sup>th</sup> Street. The Santa Clara/Alum Rock Bus Rapid Transit (BRT) Station is located on Santa Clara Street south of the Alum Rock/28<sup>th</sup> Street Station. Construction of the Alum Rock/28<sup>th</sup> Street Station would not affect any bus routes or bus stops; therefore, no mitigation is required.

### Pedestrians and Bicyclists

Construction of the Alum Rock/28<sup>th</sup> Street Station under either the Twin-Bore or Single-Bore Options would require the closure of North 28<sup>th</sup> Street between East St. James Street and Five Wounds Lane would require pedestrians and bicyclists to use North 27<sup>th</sup> Street or another alternate route, potentially increasing their travel distance and time. Pedestrians would experience greater impacts due to the greater travel times. Mitigation Measures TRA-CNST-A and TRA-CNST-B would reduce this impact, as discussed below.

Mitigation Measure TRA-CNST-A will be implemented to reduce impacts on pedestrians and bicyclists. This measure would inform residents of construction activities and where they may affect pedestrian and bicycle routes and travel times. Additionally, the outreach effort would provide an avenue for the receiving of concerns, comments, and questions from the public regarding pedestrian and bike routes and travel time impacts.



VTA will implement Mitigation Measure TRA-CNST-B to reduce impacts on pedestrians and bicyclists. This plan will provide safe travel corridors for pedestrians and bicyclists within and through construction areas or provide detour routes with wayfinding signage.

Even with implementation of these mitigation measures, construction of Alum Rock/28<sup>th</sup> Street Station with the Twin-Bore Option would have an *adverse effect* on pedestrians and bicyclists.

Construction of the Alum Rock/28<sup>th</sup> Street Station under the Single-Bore Option would require closure of 28<sup>th</sup> Street, but for much shorter durations as the station box would be constructed underground. Although the duration of closure of 28<sup>th</sup> Street would be shorter, it would still result in an adverse effect on pedestrians and bicyclists. The Single-Bore Option would result in an *adverse effect*.

## **Vehicular Traffic**

Under the Twin-Bore Option, North 28<sup>th</sup> Street between East St. James Street and Five Wounds Lane and 30<sup>th</sup> Street would be temporarily unavailable for several months to several years due to construction of the station box, system facilities, entrances and roadway modifications. Portions of East St. James Street and Five Wounds Lane not required for access to existing businesses, and the elementary school would also be closed during construction. Lane and roadway closures for several months to several years would have the potential to affect vehicular traffic traveling within and through the construction area.

Additionally, truck haul routes may impact vehicular traffic. At the Alum Rock/28<sup>th</sup> Street Station, trucks would exit at the interchange of McKee Road/East Julian Street/U.S. 101, travel west on Santa Clara Street, and then south on 28<sup>th</sup> Street. Trucks would use these same streets to return to the freeway. The proposed truck haul routes and projected volumes of material are provided in Section 5.2.4.2, *Truck Haul Routes*. Mitigation Measures TRA-CNST-A and TRA-CNST-B would reduce the impact of lane and street closures and construction vehicle traffic.

VTA will implement Mitigation Measure TRA-CNST- A to reduce impacts on vehicular traffic. This measure would inform residents of construction activities and where they may affect vehicle routes and travel times. Additionally, the outreach effort would provide an avenue for the receiving of concerns, comments, and questions from the public regarding vehicle route and travel time impacts.

VTA will implement Mitigation Measure TRA-CNST-B to reduce impacts on vehicular traffic. Implementation of the Transportation Management Plan would involve working with the City of San Jose to modify traffic lights and timing and provide flag control or temporary signalization at un-signalized intersections, and provide early signage of potential construction delays for motorists to choose alternate routes.

Even with implementation of Mitigation Measures TRA-CNST-A and TRA-CNST-B, and even though alternate parallel routes (i.e., 27<sup>th</sup> Street and U.S. 101) are available in the

vicinity, temporary lane and roadway closures around Alum Rock/28<sup>th</sup> Street Station with the Twin-Bore Option tunnel construction would have an *adverse effect* on vehicular traffic during construction.

Construction of the Single-Bore Option would also likely require closure of 28<sup>th</sup> Street, but for much shorter durations as the station box would be constructed underground. Although the duration of closure of 28<sup>th</sup> Street would be shorter, it would still result in an adverse effect on vehicular traffic. Even with implementation of Mitigation Measures TRA-CNST-A and TRA-CNST-B, vehicular traffic impacts caused by construction of the Alum Rock/28<sup>th</sup> Street Station under the Single-Bore Option would result in an *adverse effect*.

## Parking

For both the Twin-Bore and Single-Bore Options, during construction of Alum Rock/28<sup>th</sup> Street Station, less than 10 on-street publicly available parking spaces would be temporarily unavailable for several months to several years along North 28<sup>th</sup> Street, East St. James Street, North 30<sup>th</sup> Street, and Five Wounds Lane around Alum Rock/28<sup>th</sup> Street Station. Adequate on-street parking spaces would still be available to accommodate parking demand in the surrounding area; therefore, the temporary loss of parking during construction would have *no adverse effect* on parking supply in the area around the Alum Rock/28<sup>th</sup> Street Station, and mitigation is not required.

### 5.5.2.4 13<sup>th</sup> Street Ventilation Structure

For both the Twin-Bore and Single-Bore Options, the BART trackway would be in a tunnel configuration for this portion of the alignment and would not affect transportation facilities. However, the BART Extension would include the 13<sup>th</sup> Street Ventilation Structure on 13<sup>th</sup> Street north of Santa Clara Street, which includes the construction of an aboveground systems facility. Construction of this facility would require lane closures on Santa Clara and 13<sup>th</sup> Streets. To reduce traffic impacts, one lane in each direction would be maintained on Santa Clara Street; however, short-term lane closures would be required on 13<sup>th</sup> Street. The traffic disruptions to vehicular traffic, bicyclists, and pedestrians would be potentially adverse.

VTA will implement Mitigation Measure TRA-CNST-A to reduce impacts on vehicular traffic. This measure would inform residents of construction activities and where they may affect vehicle routes and travel times. Additionally, the outreach effort would provide an avenue for the receiving of concerns, comments, and questions from the public regarding vehicle route and travel time impacts.

VTA will implement Mitigation Measure TRA-CNST-B to reduce impacts on vehicular traffic. Implementation of the Transportation Management Plan would involve working with the City of San Jose to modify traffic lights and timing and provide flag control or temporary signalization at un-signalized intersections, and provide early signage of potential construction delays for motorists to choose alternate routes.

With implementation of Mitigation Measures TRA-CNST-A and TRA-CNST-B, construction of the 13<sup>th</sup> Street Ventilation Structure would have *no adverse effect* on vehicular traffic.

Single-Bore Option tunnel construction at this location would be similar to the Twin-Bore Option and similarly result in *no adverse effect*.

### 5.5.2.5 Downtown San Jose Station East Option

#### Transit

The western end of the station is located between 2<sup>nd</sup> and 3<sup>rd</sup> Streets, which is east of the existing light rail tracks on 1<sup>st</sup> and 2<sup>nd</sup> Streets. Therefore, construction of the Downtown San Jose East Option under either the Twin-Bore or Single-Bore Options would not affect light rail service, and no mitigation is required.

Existing VTA bus routes serving the area around the proposed Downtown San Jose Station East Option include routes 22, 23, 63, 64, 65, 66, 68, 72, 73, 81, 82, 168, 181, 304 and 522, and the future Alum Rock/Santa Clara BRT route. During construction of the Downtown San Jose Station East Option under the Twin-Bore Option, several bus routes would be temporarily re-routed, and bus stops would be temporarily relocated for the following existing bus routes within and near the Downtown San Jose Station East Option: 22, 23, 63, 64, 65, 81, and 522.

Under the Twin-Bore Option, construction of the Downtown San Jose Station East Option would affect VTA's Santa Clara/Alum Rock BRT Project, which is currently under construction and scheduled to be in operation in 2017. Roadway construction impacts for the Twin-Bore Option are described in Table 5-2. The 6<sup>th</sup> Street/City Hall BRT Station includes an eastbound bus stop on the south side and a westbound bus stop on the north side of Santa Clara Street between 5<sup>th</sup> and 6<sup>th</sup> Streets. Construction of the Downtown San Jose Station East Option under the Twin-Bore Option would require the closure of some bus stops during various construction phases. In addition, the BRT route would be detoured around the construction area. A temporary BRT stop would be provided during construction. For the reasons listed above, construction of the Downtown San Jose Station East Option under the Twin-Bore Option has the potential to adversely impact rapid bus service. However, VTA will ensure that appropriate measures are taken to notify riders, re-route bus routes and to relocate bus stops during construction.

VTA will implement Mitigation Measure TRA-CNST-A to reduce impacts on local and rapid bus service. This measure would inform residents of construction activities and where they may affect bus routes and travel times. Additionally, the outreach effort would provide an avenue for the receiving of concerns, comments, and questions from the public regarding bus route and travel time impacts.



Even with implementation of Mitigation Measure TRA-CNST-A, roadway impacts caused by the Downtown San Jose Station East Option under the Twin-Bore Option, as summarized in Table 5-2, would have an *adverse effect* on local bus service.

The Single-Bore Option would not involve aboveground construction except at entrances and system facilities. Construction activities would involve temporary lane closures and transit service may be disrupted or rerouted. Even with implementation of Mitigation Measure TRA-CNST-A, transit impacts caused by construction of Downtown San Jose Station East Option under the Single-Bore Option would have an *adverse effect* on transit.

## **Pedestrians and Bicyclists**

For the Twin-Bore Option, sidewalks on 3<sup>rd</sup> Street through 7<sup>th</sup> Street north and south of Santa Clara Street close to the station, and sidewalks and crosswalks on Santa Clara Street between 2<sup>nd</sup> and 7<sup>th</sup> Streets, would be temporarily closed for months at a time during various phases of construction of the Downtown San Jose Station East Option.

Bicycles are allowed on all streets in the vicinity of the Downtown San Jose Station East Option station area and there are Class II bike lanes provided along (northbound) 3<sup>rd</sup> Street and (southbound) 4<sup>th</sup> Street, between Julian Street and Reed Street. Lane and roadway closures (see Table 5-2) would have the potential to affect bicycle traffic traveling within and through the construction area. The mitigation measures below would reduce this impact.

Mitigation Measure TRA-CNST-A will be implemented to reduce bike and pedestrian impacts. This measure would inform residents of construction activities and where they may affect bike and pedestrian routes and travel times. Additionally, the outreach effort would provide an avenue for the receiving of concerns, comments, and questions from the public regarding bike and pedestrian route and travel time impacts.

Mitigation Measure TRA-CNST-B will also be implemented to reduce impacts on pedestrians and bicyclists. This Transportation Management Plan would provide safe travel corridors for pedestrians and bicyclists within and through construction areas or provide detour routes with wayfinding signage.

Even with implementation of Mitigation Measure TRA-CNST-A and TRA-CNST-B, roadway impacts caused by construction of the Downtown San Jose Station East Option under the Twin-Bore Option roadway impacts, as summarized in Table 5-2, would have an *adverse effect* on pedestrians and bicyclists.

The Single-Bore Option would also involve lane and sidewalk closures but for a shorter duration than the Twin-Bore Option. Nonetheless, even with implementation of Mitigation Measures TRA-CNST-A and TRA-CNST-B, roadway impacts caused by construction of the Downtown San Jose Station East Option under the Single-Bore Option would have an *adverse effect* on pedestrians and bicyclists.

## Vehicular Traffic

The Downtown San Jose Station East Option would be constructed along Santa Clara Street between 2<sup>nd</sup> Street and 7<sup>th</sup> Street. Major construction activities associated with the Twin-Bore Option that have the potential to impact roadways are described in Table 5-2.

For the Twin-Bore Option, north and south of Santa Clara Street, 3<sup>rd</sup> through 7<sup>th</sup> Streets, and Santa Clara Street between 3<sup>rd</sup> and 7<sup>th</sup> Streets, would be temporarily closed for months at a time during various phases of construction of the Downtown San Jose Station East Option.

Santa Clara Street is the major thoroughfare in Downtown San Jose with a variety of retail, office, restaurant, and residential uses fronting the street. Construction of the Downtown San Jose Station would involve cut-and-cover activities within Santa Clara Street, as the station would be underground. Construction of the Downtown San Jose Station East Option under the Twin-Bore Option is likely to result in severe disruptions to vehicular, bicycle, and pedestrian traffic. The construction activities would be spread over several blocks, resulting in lane and street closures over an extended period of time (lasting several months at any given location) and reoccurring during various construction phases. Although parallel routes exist within the Downtown area and motorists, cyclists, and pedestrians would be detoured to these routes during construction, the lane and street closures of Santa Clara Street during construction would continue to cause delays and disruptions to vehicular, bicycle, and pedestrian traffic.

Additionally, two truck haul routes from the west and east would increase traffic on St. James Street, Market Street, Santa Clara Street, Notre Dame Street, 11<sup>th</sup> Street and 10<sup>th</sup> Street. The proposed truck haul routes and projected volumes of material are provided in Section 5.2.4.2.

Although there are no local policies or thresholds for assessing construction-period traffic impacts, disruption to vehicular, bicycle, and pedestrian traffic in Downtown San Jose due to extended construction along Santa Clara Street would cause an adverse effect under NEPA. Mitigation Measures TRA-CNST-A and TRA-CNST-B will be implemented to minimize the traffic disruptions and to accommodate local businesses where possible.

Mitigation Measure TRA-CNST-A will be implemented to reduce impacts on vehicular traffic. This measure would inform residents of construction activities and where they may affect vehicle routes and travel times. Additionally, the outreach effort would provide an avenue for the receiving of concerns, comments, and questions from the public regarding vehicle route and travel time impacts.

Mitigation Measure TRA-CNST-B will also be implemented to reduce impacts on vehicular traffic. Implementation of the Transportation Management Plan would involve working with the cities to modify traffic lights and timing, provide flag control or temporary signalization at un-signalized intersections, and provide early signage of potential construction delays for motorists to choose alternate routes.

Even with implementation of Mitigation Measures TRA-CNST-A and TRA-CNST-B, roadway impacts caused by construction of the Downtown San Jose East under the Twin-Bore Option, as summarized in Table 5-2, would have an *adverse effect* on vehicular traffic.

The Single-Bore Option would involve aboveground construction at entrances and system facilities. Construction activities would involve temporary lane closures, and vehicle traffic may require rerouting. Even with implementation of Mitigation Measures TRA-CNST-A and TRA-CNST-B, roadway impacts caused by construction of the Downtown San Jose Station East Option under the Single-Bore Option would have an *adverse effect* on vehicular traffic.

### Parking

For the Twin-Bore Option, construction of the Downtown San Jose Station East Option would remove approximately 310 off-street (at VTA’s Mitchell Block property off Market Street) and 60 on-street publicly available parking spaces along Santa Clara Street between 2<sup>nd</sup> and 7<sup>th</sup> Streets. For the Single-Bore Option, the number of on-street parking spaces removed would be less than under the Twin-Bore Option. These parking spaces would be removed at the start of construction and would remain unavailable throughout the entire duration of construction, resulting in an *adverse effect* on parking. With implementation of Mitigation Measures TRA-CNST-A and TRA-CNST-C, construction of the Downtown San Jose Station East Option under both the Twin-Bore and Single-Bore Options would have *no adverse effect* on parking.

The Downtown San Jose Station East Option is located in San Jose’s Downtown core and is served by multiple public transportation services such as light rail, bus, and future BART and bus rapid transit. The City of San Jose’s General Plan and Specific Plan identify the area around the station for infill and high-density development due to the proximity of a variety of public transportation services. VTA will work with the City of San Jose as they further develop parking management strategies to encourage multi-modal access to the Downtown San Jose area.

**Table 5-2: Downtown San Jose Station Twin-Bore Roadway Construction Impacts**

Activity	Duration	Adverse Effects on Roadways
Advanced Utility Relocations	16–24 months	Temporary lane closures and some street closures along Santa Clara Street – one block, or one block and one intersection, or two blocks and one intersection at a time – for periods of up to 3 months at a time.
Support of Excavation Wall Installation	12–18 months	Temporary street closures along Santa Clara Street – one block or one block and one intersection, or two blocks and one intersection at a time – for periods of up to 3 months at a time. Light Rail Transit will require bus bridges at 1 <sup>st</sup> and 2 <sup>nd</sup> Street intersections for up to 3 months at each intersection.



Activity	Duration	Adverse Effects on Roadways
Decking Installation	1–6 months	Temporary street closures along Santa Clara Street – one block or one block and one intersection, or two blocks and one intersection at a time – for approximately 2 weeks to 1 month at a time.
Station Box Excavation	10–18 months	Intermittent lane closures along Santa Clara Street.
Tunnel Boring Machine Removal	2–4 weeks	Intermittent lane closures on each end of the station – up to 4 weeks four times.
Station Structure Construction	18–30 months	Intermittent lane closures along Santa Clara and up to 2-month street closure of Market Street.
Decking Remove, Backfill and Street Restoration (includes Street Resurfacing, Landscape, Sidewalk, Signals, Lighting)	18–24 months	Temporary one-block or one block and one intersection street closures of 1 to 2 months, with intermittent lane closures along Santa Clara Street and the effected cross street.
Source: VTA 2016.		
Note: Station construction is projected to last less than six years.		

### 5.5.2.6 Downtown San Jose Station West Option

#### Transit

For the Twin-Bore Option only, during construction of the Downtown San Jose Station West Option, light rail service would be interrupted at Santa Clara Street at both 1<sup>st</sup> and 2<sup>nd</sup> Streets due to cut-and-cover construction of the station box, and the Santa Clara Light Rail Station would be closed for several months at a time for construction activities. Although bus bridge connections would be provided between the Paseo de San Antonio and St. James Stations, light rail transit riders would experience delays during light rail service closures. The closure of light rail service during construction of the Downtown San Jose Station West Option under the Twin-Bore Option would have the potential to cause an adverse effect on light rail transit services.

Mitigation Measure TRA-CNST-A will be implemented to reduce impacts on transit. This measure would inform residents of construction activities and where they may affect bus routes and travel times. Additionally, the outreach effort would provide an avenue for the receiving of concerns, comments, and questions from the public regarding bus route and travel time impacts.

Mitigation Measure TRA CNST-B will also be implemented to reduce impacts on bus service. Bus bridge service will be provided during the temporary closure of light rail service (Downtown San Jose Station West Option only).

Existing bus routes serving the area around the Downtown San Jose Station West Option include routes 22, 23, 63, 64, 65, 66, 68, 72, 73, 81, 82, 168, 181, 304, 323, 522, Monterey/Salinas Transit Route 86, and the future Alum Rock/Santa Clara BRT route. During construction, all these bus routes would be temporarily re-routed and bus stops would be temporarily relocated under the Twin-Bore Option.

Construction of the Downtown San Jose Station West Option under the Twin-Bore Option would affect the Santa Clara/Alum Rock BRT Project, which is currently under construction and scheduled to be in operation in 2016. The Transit Mall BRT Station, which includes an eastbound bus stop on the south side and a westbound bus stop on the north side of Santa Clara Street between 1<sup>st</sup> and 2<sup>nd</sup> Streets, is currently under construction. Construction of the Downtown San Jose Station West Option would require the closure of these some bus stops during construction. In addition, the BRT route would be detoured around the construction area. A temporary BRT stop would be provided during construction. Detouring of BRT around the construction area would adversely affect BRT service and schedules. Construction of the Downtown San Jose Station West Option has the potential to adversely affect bus service during construction.

Although mitigation has been identified (TRA-CNST-A), the disruption of existing light rail and bus service during roadway construction of the Downtown San Jose Station West Option under the Twin-Bore Option, as summarized in Table 5-2, would cause an *adverse effect* on transit services.

The Single-Bore Option would not involve aboveground construction except at entrances and system facilities. Construction activities would involve temporary lane closures, and transit service may be disrupted or rerouted. Even with implementation of Mitigation Measure TRA-CNST-A, transit impacts caused by construction of Downtown San Jose Station West Option under the Single-Bore Option would have an *adverse effect* on transit.

## **Pedestrians and Bicyclists**

For the Twin-Bore Option, sidewalks along Market, Santa Clara, 1<sup>st</sup>, 2<sup>nd</sup>, and 3<sup>rd</sup> Streets would be temporarily closed for months at a time during various phases of construction of the Downtown San Jose Station West Option, which would adversely affect pedestrians.

Bicyclists are allowed on all streets in the vicinity of the Downtown San Jose Station West Option station area, and there are Class II bike lanes provided along (northbound) 3<sup>rd</sup> Street and (southbound) 4<sup>th</sup> Street, between Julian Street and Reed Street. Lane and roadway closures would have the potential to affect bicycle traffic traveling within and through the construction area.

Mitigation Measure TRA-CNST-A will be implemented to reduce impacts on pedestrians and bicyclists. This measure would inform residents of construction activities and where they may affect bike and pedestrian routes and travel times. Additionally, the outreach effort would provide an avenue for the receiving of concerns, comments, and questions from the public regarding bike and pedestrian route and travel time impacts.

Mitigation Measure TRA-CNST-B will be implemented to reduce impacts on pedestrians and bicyclists. This Transportation Management Plan would provide safe travel corridors for pedestrians and bicyclists within and through construction areas or provide detour routes with wayfinding signage.

Although VTA would implement Mitigation Measures TRA-CNST-A and TRA-CNST-B, construction of the Downtown San Jose Station West Option under the Twin-Bore Option, as summarized in Table 5-2, would have an *adverse effect* on pedestrians and bicyclists.

The Single-Bore Option would also involve lane and sidewalk closures but for a shorter duration than the Twin-Bore Option. Nonetheless, even with implementation of Mitigation Measures TRA-CNST-A and TRA-CNST-B, construction of the Downtown San Jose Station West Single-Bore Option would also have an *adverse effect* on pedestrians and bicyclists.

## **Vehicular Traffic**

For both the Twin-Bore and Single-Bore Options, the Downtown San Jose Station West Option would be constructed along Santa Clara Street between 4<sup>th</sup> Street and San Pedro Street.

For the Twin-Bore Option, Market Street, 1<sup>st</sup> Street, 2<sup>nd</sup> Street, and 3<sup>rd</sup> Street north and south of Santa Clara Street, and Santa Clara Street between San Pedro and 4<sup>th</sup> Streets would be temporarily closed for months at a time during various phases of construction of the Downtown San Jose Station West Option. Major construction activities for the Twin-Bore Option are outlined in Table 5-2. Santa Clara Street is the major thoroughfare in Downtown San Jose with a variety of retail, office, restaurant, and residential uses fronting the street. Construction of the Downtown San Jose Station would involve cut-and-cover activities within Santa Clara Street, as the station would be underground. Construction of the Downtown San Jose Station West Option under the Twin-Bore Option is likely to result in severe disruptions to vehicular, bicycle, and pedestrian traffic. The construction activities would be spread over several blocks resulting in lane and street closures over an extended period of time (lasting several months at any given location) and reoccurring during various construction phases. Although parallel routes exist within the Downtown area and motorists, cyclists, and pedestrians would be detoured to these routes during construction, the lane and street closures of Santa Clara Street during construction would continue to cause delays and disruptions to vehicular, bicycle, and pedestrian traffic.

Additionally, two truck haul routes from the west and east would increase traffic on St. James Street, Market Street, Santa Clara Street, Notre Dame Street, 11<sup>th</sup> Street, and 10<sup>th</sup> Street. The proposed truck haul routes and projected volumes of material are provided in Section 5.2.4.2.

Although there are no local policies or thresholds for assessing construction-period traffic impacts, disruption to vehicular, bicycle, and pedestrian traffic in Downtown San Jose due to extended construction along Santa Clara Street would cause an *adverse effect* under NEPA. Mitigation Measures TRA-CNST-A and TRA-CNST-B will be implemented to minimize the traffic disruptions and to accommodate local businesses where possible.

Mitigation Measure TRA-CNST-A will be implemented to reduce impacts on vehicular traffic. This measure would inform residents of construction activities and where they may



affect vehicle routes and travel times. Additionally, the outreach effort would provide an avenue for the receiving of concerns, comments, and questions from the public regarding vehicle route and travel time impacts.

Mitigation Measure TRA-CNST-B will be implemented to reduce impacts on vehicular traffic. Implementation of the Transportation Management Plan would involve working with the cities to modify traffic lights and timing to; provide flag control or temporary signalization at un-signalized intersections; and provide early signage of potential construction delays for motorists to choose alternate routes.

Although VTA will implement Mitigation Measures TRA-CNST-A and TRA-CNST-B, roadway impacts caused by the construction of the Downtown San Jose West Option under the Twin-Bore Option, as described in Table 5-2, would have an *adverse effect* on vehicular traffic.

The Single-Bore Option would involve aboveground construction at entrances and system facilities and Santa Clara Street, and adjacent roadways may be closed. Even with implementation of Mitigation Measures TRA-CNST-A and TRA-CNST-B, roadway impacts caused by construction of the Downtown San Jose Station East Option would have an *adverse effect* on vehicular traffic.

## **Parking**

For the Twin-Bore Option, construction of the Downtown San Jose Station West Option would remove approximately 310 off-street (at VTA's Mitchell Block property at Market Street) and 54 on-street publicly available parking spaces. For the Single-Bore Option, the number of on-street parking spaces removed would be less under than the Twin-Bore Option. These parking spaces would be removed at the start of construction and would remain unavailable throughout the entire duration of construction, resulting in an *adverse effect* on parking. With implementation of Mitigation Measures TRA-CNST-A and TRA-CNST-C, construction of the Downtown San Jose Station West Option under both the Twin-Bore and Single-Bore Options would have *no adverse effect* on parking. The Downtown San Jose Station is located in San Jose's Downtown core and is served by multiple public transportation services such as light rail, bus, and future BART and BRT. The City of San Jose's General Plan and Specific Plan identify the area around the station for infill and high-density development due to its proximity to a variety of public transportation services. VTA will work with the City of San Jose as they further develop parking management strategies to encourage multi-modal access to the Downtown San Jose area.

### **5.5.2.7 Diridon Station (South and North Options)**

#### **Transit**

Existing light rail service at Diridon Station consists of the Vasona Corridor (Mountain View – Winchester). The Diridon light rail station is located immediately west of the

Amtrak/Caltrain station and east of Laurel Grove Lane. The light rail line runs underground starting at South Montgomery Street and then resurfaces on the west side of the Diridon Caltrain Station tracks. The future Diridon Station South and North Options would both be located underground and north of the existing light rail line and would not encroach into the right-of-way (ROW) of existing light rail services. Therefore, construction of the Diridon Station South and North Options under both the Twin-Bore and Single-Bore Options would have *no effect* on existing light rail service, and no mitigation is required.

Existing bus routes serving the area around the Diridon Station include routes 22, 63, 64, 65, 68, and Express Routes 168, 181, and 522. Three inter-county bus services (HWY 17, MST 55, and MST 86) and the free DASH shuttle also serve the area around the Diridon Station South and North Options. During construction of both South and North Options under both the Twin-Bore and Single-Bore Options, these bus routes would be temporarily re-routed, and bus stops would be temporarily relocated. Construction of the Diridon Station South and North Options under both the Twin-Bore and Single-Bore Options would affect the Santa Clara/Alum Rock BRT Project, which is currently under construction and scheduled to be in operation in 2016. The Arena BRT Station, which includes an eastbound bus stop on the south side and a westbound bus stop on the north side of Santa Clara Street between Cahill and Montgomery Streets, is currently under construction. Construction of the Diridon Station South Option would not close these two bus stops or detour the BRT route. However, the North Option would temporarily relocate the eastbound bus stops to better serve riders. In addition, the temporary closure of the bus transit center would require the detouring and re-routing of bus service and the temporary relocation of bus stops. Displaced buses may be temporarily located along Santa Clara Street at or around the BRT station. This may impact BRT service and schedules. Therefore, construction of the Diridon Station South and North Options has the potential to adversely affect bus service during construction under both the Twin-Bore and Single-Bore Options.

Mitigation Measure TRA-CNST-A will be implemented to reduce impacts on bus service. This measure would inform residents of construction activities and where they may affect bus routes and travel times. Additionally, the outreach effort would provide an avenue for the receiving of concerns, comments, and questions from the public regarding bus route and travel time impacts.

Mitigation Measure TRA CNST-B will be implemented to reduce impacts on bus service. VTA will coordinate with transit providers as necessary to ensure that appropriate measures are taken to re-route bus routes and to relocate bus stops during construction.

Although VTA will implement Mitigation Measures TRA-CNST-A and TRA-CNST-B, construction of the Diridon Station South and North Options under both the Twin-Bore and Single-Bore Options would have an *adverse effect* on bus service.

Caltrain service is provided at Diridon Caltrain Station. The tunnel for the Single-Bore Option would be approximately 70 feet below surface, and the entrances would not impact the existing railroad tracks. Therefore, Caltrain service would not be affected during

construction. However, for the Twin-Bore Option, construction of the Diridon BART Station North Option would affect existing Caltrain service. The eastern most track would need to be taken out of service during construction of the BART station. Service on this track would be temporarily shifted during construction to another track and would require coordination with Caltrain. Therefore, construction of the Diridon Station North Option under the Twin-Bore Option would affect Caltrain service during construction.

VTA will implement Mitigation Measure TRA-CNST-A (Construction Education and Outreach Plan) to coordinate this construction and reduce impacts on Caltrain rail service. Although VTA will implement Mitigation Measure TRA-CNST-A and coordinate with Caltrain for construction activities, construction of the Diridon Station North Option (under the Twin-Bore Option) would result in an *adverse effect* on heavy rail service.

## **Pedestrians and Bicyclists**

For both the Twin-Bore and Single-Bore Options, Autumn Street would be closed south of Santa Clara Street near the station area during construction of the Diridon Station South and North Options, and pedestrian and bicycle traffic would be detoured to Montgomery Street. Montgomery Street and Cahill Street would be closed from The Alameda to the south side of the station area, and pedestrian and bicycle traffic would be detoured to Autumn Street south of the station area. The Diridon Station North would also require lane closures on Santa Clara Street. These closures would adversely affect pedestrians and bicyclists during construction.

Mitigation Measure TRA-CNST-A will be implemented to reduce impacts on pedestrians and bicyclists. This measure would inform residents of construction activities and where they may affect bike and pedestrian routes and travel times. Additionally, the outreach effort would provide an avenue for the receiving of concerns, comments, and questions from the public regarding bike and pedestrian route and travel time impacts.

Mitigation Measure TRA-CNST-B will also be implemented to reduce impacts on pedestrians and bicyclists. This Transportation Management Plan would provide safe travel corridors for pedestrians and bicyclists within and through construction areas or provide detour routes with wayfinding signage.

Even with the implementation of Mitigation Measures TRA-CNST-A and TRA-CNST-B, sidewalk, crosswalk, and roadway closures during the construction of the Diridon Station South and North Options under both the Twin-Bore and Single-Bore Options would result in an *adverse effect* on pedestrians and bicyclists.

## **Vehicular Traffic**

For the Twin-Bore Option, construction of the Diridon Station South and North Options would require full and partial street closures of Autumn, Montgomery, and Cahill Streets. Full closure of these streets south of Santa Clara Street near the station would occur for several months each while utilities are being relocated and/or decking is installed. No more than one street would be closed at any given time. Partial closure of these streets near the



station would last for months at a time throughout construction. Where feasible, VTA will work with the construction contractor to maintain at least one northbound and one southbound direction of traffic on Autumn, Montgomery, and Cahill Streets throughout construction for two-way streets. Partial and full street closures would cause adverse impacts on vehicular traffic within the station area during construction.

Additionally, truck haul routes may impact traffic on West Julian Street, Almaden Boulevard, Santa Clara Street, Montgomery Street, Autumn Street, Notre Dame Street, and Bird Avenue. The proposed truck haul routes and projected volumes of material are provided in Section 5.2.4.2.

Mitigation Measure TRA-CNST-A will be implemented to reduce impacts on vehicular traffic. This measure would inform residents of construction activities and where they may affect vehicle routes and travel times. Additionally, the outreach effort would provide an avenue for the receiving of concerns, comments, and questions from the public regarding vehicle route and travel time impacts.

Mitigation Measure TRA-CNST-B will also be implemented to reduce impacts on vehicular traffic. Implementation of the Transportation Management Plan would involve working with the cities to modify traffic lights and timing to; provide flag control or temporary signalization at un-signalized intersections; and provide early signage of potential construction delays for motorists to choose alternate routes.

Although VTA will implement Mitigation Measures TRA-CNST-A and TRA-CNST-B, construction of the Diridon Station South and North Options under both the Twin-Bore Option would have an *adverse effect* on vehicular traffic.

While the Single-Bore Option would not require as extensive full and partial street closures, traffic would still be disrupted. Although VTA will implement Mitigation Measures TRA-CNST-A and TRA-CNST-B, the Single-Bore Option would have an *adverse effect* on vehicular traffic.

## **Parking**

For the Twin-Bore Option, during construction of Diridon Station, approximately 635 off-street and 80 on-street publicly available parking spaces would be removed in the area bounded by Santa Clara Street/The Alameda to the north, San Fernando Street to the south, Los Gatos Creek to the east, and the railroad corridor to the west. For the Single-Bore Option, the number of on-street parking spaces removed would be less than under the Twin-Bore Option. Off-street parking spaces located within public and private property would be removed at the start of construction and would remain unavailable throughout the entire duration of construction. On-street parking spaces would be unavailable for at least several months at a time throughout the entire duration of construction, resulting in an adverse effect.

Two planning exercises are underway with Diridon area stakeholders to study parking demand and develop parking management strategies in preparation for the construction of several planned transit and development projects in and around the Diridon Station area. First, the City of San Jose is currently leading an effort in partnership with VTA, the Peninsula Corridor Joint Powers Board, and area stakeholders to develop an interim short-term parking plan through 2025 that will address parking needs in the Diridon Station area. In addition, VTA, the City of San Jose, Peninsula Corridor Joint Powers Board, and California High-Speed Rail Authority are participating in the Diridon Intermodal Study, which will analyze long-term multimodal access in and around Diridon Station in 2025 and beyond once proposed transit investments and development projects are in place. During the development of both the interim parking plan and the Diridon Intermodal Study, VTA will work with existing and future transit providers in the Diridon Station area to evaluate parking demand based on updated transit patron mode of access data and/or VTA policies established for transit park-and-ride lots and/or joint development parking requirements. The interim parking plan and the Diridon Intermodal Study will address the provision, location, and management of parking in the area; identify an overall strategy for meeting parking needs with stakeholders; allow for shared parking among area transit providers, the SAP Center, and future development; and evaluate strategies that would encourage transit-supportive access to the area and non-auto travel.

The mitigation measures below would reduce the impacts due to construction on traffic and parking.

Mitigation Measure TRA-CNST-A will be implemented to reduce impacts on traffic and parking. This measure would inform residents of construction activities and where they may affect parking. Additionally, the outreach effort would provide an avenue for the receiving of concerns, comments, and questions from the public regarding parking impacts.

Mitigation Measure TRA-CNST-C will also be implemented to reduce impacts on parking.

With implementation of Mitigation Measures TRA-CNST-A and TRA-CNST-C, construction of the Diridon Station South and North Options under both the Twin-Bore and Single-Bore Options would have *no adverse effect* on parking.

### **5.5.2.8 Stockton Avenue Ventilation Structure**

For the Twin-Bore and Single-Bore Options, the BART trackway would be in a tunnel configuration between Diridon Station and the West Tunnel Portal north of I-880 and would not affect transportation facilities. However, the BART Extension would include the Stockton Avenue Ventilation Structure on Stockton Avenue, south of Taylor Street. Construction of this facility would require temporary lane closures on Stockton Avenue. To reduce traffic impacts, one lane in each direction would be maintained on Stockton Avenue during construction activities. The traffic disruptions to vehicular traffic, bicyclists, and pedestrians would result in an adverse impact, and mitigation measures below would reduce this impact.

Mitigation Measure TRA-CNST-A will be implemented to reduce impacts on vehicular traffic. This measure would inform residents of construction activities and where they may affect vehicle routes and travel times. Additionally, the outreach effort would provide an avenue for the receiving of concerns, comments, and questions from the public regarding vehicle route and travel time impacts.

Mitigation Measure TRA-CNST-B will also be implemented to reduce impacts on vehicular traffic. Implementation of the Transportation Management Plan would involve working with the cities to modify traffic lights and timing to; provide flag control or temporary signalization at un-signalized intersections; and provide early signage of potential construction delays for motorists to choose alternate routes.

With implementation of Mitigation Measures TRA-CNST-A and TRA-CNST-B, for both the Twin-Bore and Single-Bore Options, temporary construction impacts at the Stockton Avenue ventilation structure would have *no adverse effect* on vehicular traffic.

### **5.5.2.9 Newhall Maintenance Facility**

For the Twin-Bore and Single-Bore Options, construction of the Newhall Maintenance Facility would cause the addition of traffic from construction vehicles and trucks accessing the site and delivering supplies and materials to the construction site throughout the duration of construction. Construction activities at the Newhall Maintenance Facility would include construction of all components of the maintenance facility in addition to construction of the West Tunnel Portal, 115-kilovolt line connection to the Pacific Gas and Electric Company (PG&E) substation, and systems facilities. The maintenance facility site would also be used as a laydown and storage area for construction of the tunnel. Large areas within the maintenance facility north of Interstate (I-) 880 would be used for tunnel muck drying and storage and materials and equipment storage. Construction vehicles and trucks carrying equipment, supplies, or tunnel muck would access the site from I-880 to Coleman Avenue. From Coleman Avenue, construction vehicles would use either Newhall Drive or Brokaw Road to access the facility. Coleman Avenue, Newhall Drive, Newhall Street, and Brokaw Road would experience heavy construction vehicle traffic during construction for both the Twin-Bore and Single-Bore Options.

Mitigation Measure TRA-CNST-A will be implemented to reduce impacts on vehicular traffic. This measure would inform residents of construction activities and where they may affect vehicle routes and travel times. Additionally, the outreach effort would provide an avenue for the receiving of concerns, comments, and questions from the public regarding vehicle route and travel time impacts.

Mitigation Measure TRA-CNST-B will also be implemented to reduce impacts on vehicular traffic. Implementation of the Transportation Management Plan would involve working with the cities to modify traffic lights and timing to; provide flag control or temporary signalization at un-signalized intersections; and provide early signage of potential construction delays for motorists to choose alternate routes.

Although VTA will implement Mitigation Measures TRA-CNST-A and TRA-CNST-B, construction of the Newhall Maintenance Facility and the West Tunnel Portal would have an *adverse effect* on vehicular traffic, bicyclists, and pedestrians for both the Twin-Bore and Single-Bore Options.

### 5.5.2.10 Santa Clara Station

#### Transit

No light rail service is provided at or near the Santa Clara Station. Therefore, construction of Santa Clara Station under both the Twin-Bore and Single-Bore Options would not affect light rail service during construction, and no mitigation is required.

Existing bus routes serving the area around the Santa Clara Station include bus routes 22, 32, 60, and 81. Express bus route 522 and the free shuttle 10 from the Santa Clara Transit Center to the Metro Airport light rail transit (LRT) Station also serve the area around the Santa Clara Station. The closest bus routes are along Coleman Avenue and would not be impacted during construction. El Camino Real BRT is located west of the Caltrain tracks and would not be affected by construction. Therefore, construction of Santa Clara Station would not affect bus service under both the Twin-Bore and Single-Bore Options, and no mitigation is required.

Currently Amtrak, Caltrain, Altamont Corridor Express (ACE), Capitol Corridor, and Union Pacific Railroad (UPRR) operate commuter rail and freight rail services through the existing rail corridor to the west and across railroad tracks from the BART alignment. Construction of the Santa Clara Station and the Newhall Maintenance Facility would not adversely affect the existing operations of freight and passenger rail through this existing rail corridor. Therefore, construction of the Santa Clara Station and the Newhall Maintenance Facility would have *no adverse effect* on heavy rail service during construction under both the Twin-Bore and Single-Bore Options, and no mitigation is required.

#### Pedestrians and Bicyclists

For the Twin-Bore and Single-Bore Options, construction access for Santa Clara Station would be provided from Brokaw Road, which is a dead end street. However, VTA is currently constructing a pedestrian undercrossing from the center platform at the Santa Clara Caltrain Station to Brokaw Road. The undercrossing would be completed by 2017 and enable pedestrians and bicyclists to cross under the existing railroad tracks and travel from Santa Clara to San Jose. The undercrossing may be closed periodically during the construction of the BART Extension when construction activities would conflict with pedestrian and bicycle access, for example during reconstruction of Brokaw Road prior to the opening of the Santa Clara Station. Therefore, construction activities have the potential to result in an *adverse effect* on pedestrians and bicyclists.

Mitigation Measure TRA-CNST-A will be implemented to reduce impacts on pedestrians and bicyclists. This measure would inform residents of construction activities and where they



may affect bicycle and pedestrian routes and travel times. Additionally, the outreach effort would provide an avenue for the receiving of concerns, comments, and questions from the public regarding bicycle and pedestrian route and travel time impacts.

Mitigation Measure TRA-CNST-B will also be implemented to reduce impacts on pedestrians and bicyclists. This Transportation Management Plan would provide safe travel corridors for pedestrians and bicyclists within and through construction areas or provide detour routes with wayfinding signage.

Even with the implementation of Mitigation Measures TRA-CNST-A and TRA-CNST-B, sidewalk, crosswalk, and roadway closures during construction of the Santa Clara Station under both the Twin-Bore and Single-Bore Options would result in an *adverse effect* on pedestrians and bicyclists.

## **Vehicular Traffic**

For the Twin-Bore and Single-Bore Options, the Santa Clara Station construction activities would gain access from Brokaw Road, which is a dead end street. Brokaw Road connects to Coleman Avenue, which is a major arterial. During construction, Brokaw Road would remain open to vehicles accessing the existing businesses. The proposed truck haul routes and projected volumes of material are provided in Section 5.2.4.2. Adverse effects from the low volume of peak hour trucks on traffic level of service would not be substantial, except when construction activities for Santa Clara Station overlap with those for the West Portal and Newhall Maintenance Facility. Therefore, construction activities would have an *adverse effect* on vehicular traffic.

Mitigation Measure TRA-CNST-A will be implemented to reduce impacts on vehicular traffic. This measure would inform residents of construction activities and where they may affect vehicle routes and travel times. Additionally, the outreach effort would provide an avenue for the receiving of concerns, comments, and questions from the public regarding vehicle route and travel time impacts.

Mitigation Measure TRA-CNST-B will also be implemented to reduce impacts on vehicular traffic. Implementation of the Transportation Management Plan would involve working with the cities to modify traffic lights and timing to provide flag control or temporary signalization at un-signalized intersections and provide early signage of potential construction delays for motorists to choose alternate routes.

Although VTA will implement Mitigation Measures TRA-CNST-A and TRA-CNST-B, construction of the Santa Clara Station under both the Twin-Bore and Single-Bore Options would have an *adverse effect* on vehicular traffic.

## **Parking**

For the Twin-Bore and Single-Bore Options, During construction of the Santa Clara Station, approximately 42 on-street publicly available parking spaces would be temporarily

unavailable for the duration of construction along Brokaw Road between the existing railroad tracks and Coleman Avenue. Adequate on-street parking spaces would still be available to accommodate parking demand in the surrounding area. Therefore, the temporary loss of parking during construction would result in *no adverse effect* on parking supply in this area around the Santa Clara Station, and mitigation is not required.

## 5.5.3 Air Quality

### 5.5.3.1 Methodology for Construction Impacts

#### Criteria Pollutants, Ozone Precursors, and Greenhouse Gas Emissions

Construction associated with the BART Extension would generate criteria pollutant emissions from the following construction activities: (1) utility relocation for underground and overhead utilities along the corridor; (2) site preparation/excavation related to the three underground stations: Alum Rock/28<sup>th</sup> Street, Downtown San Jose (East or West Option), and Diridon (South or North Option); (3) cut-and-cover operations and excavation of tunnels by use of one or more Tunnel Boring Machines (TBMs); (4) demolition of existing structures, buildings, pavement, and other site features; (5) construction of ventilation facilities, system facilities, station box, track work including crossovers, station campuses, and the Newhall Maintenance Facility; (6) construction workers traveling to and from construction sites; and (7) delivery of construction supplies to construction sites and hauling of debris from construction sites.

These construction activities would create emissions of dust (particulate matter), fumes, equipment exhaust, and other air contaminants. According to the construction schedule (see Figure 5-1), construction of the BART Extension (Twin-Bore or Single-Bore Option) would start in 2017 and would take approximately 8 years.

Exhaust emissions associated with construction of the BART Extension were estimated using a spreadsheet methodology and emission factors and emission rates obtained from the California Air Resources Board's (ARB's) EMFAC2014 for on-road vehicle and Appendix A, the data tables used by CalEEMod (version 2013.2.2) for off-road construction equipment. EMFAC is ARB's model for estimating emissions from on-road vehicles in California, and CalEEMod is a statewide land use emissions computer model designed to provide a uniform platform for government agencies, land use planners, and environmental professionals to quantify potential criteria pollutants emissions for a variety of land use projects. Note that CalEEMod does not generate construction-related nitrogen dioxide (N<sub>2</sub>O) emission factors for diesel-powered equipment. Thus, N<sub>2</sub>O emission factors for diesel equipment were calculated based on the amount of diesel fuel used and a conversion factor of 0.3316 gram N<sub>2</sub>O per gallon fuel. The N<sub>2</sub>O emissions from gasoline vehicles were estimated to be 4.16 percent of total nitrogen oxide (NO<sub>x</sub>) emissions. The two mentioned approaches are described on ARB's website (ARB 2013). Fugitive dust would be generated by demolition of existing roadways, site grading, and from other construction emissions were calculated

assuming that 20 pieces of heavy-duty construction equipment would be operating simultaneously 16 hours a day along the corridor. The equipment could be spread throughout the length of the corridor during construction activities. Offsite emissions associated with the hauling trips were accounted for based on the estimated total number of truck trips as shown in Table 5-1. Emission factors were based on assumed EMFAC2014 vehicle categories, with all haul trucks and material deliveries assumed to be EMFAC Heavy-Heavy Duty Diesel Tractor Trucks (T7).

Details of the emissions analysis including calculation sheets and assumptions used for the CalEEMod model runs are provided in *VTA's BART Silicon Valley—Phase II Extension Project Air Quality Study* (Terry A. Hayes Associates, Inc. 2016).

## Construction Emissions

Construction emissions would vary substantially from day to day, depending on the level of activity, the specific type of operation, and, for dust, the prevailing weather conditions. Construction of the BART Extension has the potential to create air quality impacts through the use of heavy-duty construction equipment and haul trucks, and through vehicle trips generated by construction workers traveling to and from the various construction sites along the alignment. NO<sub>x</sub> emissions would primarily result from the use of construction equipment and haul trucks.

Detailed day-by-day construction equipment data is not available at this stage of the planning process. It was assumed that up to 20 pieces of heavy-duty equipment would operate 16 hours per day along the corridor (i.e., 320 hours of equipment operations per day). In addition, haul and concrete truck emissions were calculated for each component. It was conservatively assumed that truck activity would occur concurrently, and that the truck activity would overlap with equipment emissions.

Table 5-3 shows equipment (onsite) and truck exhaust (offsite) emissions associated with the BART Extension. Maximum emissions would exceed the Bay Area Air Quality Management District (BAAQMD) significance threshold for NO<sub>x</sub> under both the Twin-Bore and Single-Bore Options. The construction thresholds published by the BAAQMD have been used as an indicator for emissions to result in an adverse effect. Refer to the CEQA analysis in Chapter 6, Section 6.3, *Air Quality*, for the assessment of the BAAQMD construction thresholds.

**Table 5-3: Construction Emissions Related to the BART Extension Table**

Criteria Pollutant or Ozone Precursor	Pounds per Day				
	ROGs	NO <sub>x</sub>	CO	PM10	PM2.5
<b>Onsite Emissions (Equipment Exhaust): Twin-Bore and Single-Bore Options</b>					
Unmitigated	18	180	129	9	8
Mitigated (Tier 3 Exhaust Standards)	6	21	139	6	6
<b>Offsite Emissions (Haul Truck Exhaust): Twin-Bore Option</b>					
Alum Rock/28 <sup>th</sup> Street Station	1	20	4	< 1	< 1
Downtown San Jose Station and Crossover Structure	1	41	8	1	1
Diridon Station (South and North Options)	1	41	8	1	1
13 <sup>th</sup> Street Ventilation Facility	1	20	4	< 1	< 1
Stockton Avenue Ventilation Facility	1	20	4	< 1	< 1
West Portal	1	36	7	1	< 1
East Portal	2	56	11	1	1
Tunnel (muck) – West Portal to Downtown San Jose Station	1	26	5	1	< 1
Tunnel (muck) – East Portal to Downtown San Jose Station	1	26	5	1	< 1
<b>Offsite Emissions (Haul Truck Exhaust): Single-Bore Option</b>					
Alum Rock/28 <sup>th</sup> Street Station	1	20	4	< 1	< 1
Downtown San Jose Station (East and West Options)	1	20	4	< 1	< 1
Diridon Station (South and North Options)	1	20	4	< 1	< 1
13 <sup>th</sup> Street Ventilation Structure	< 1	10	2	< 1	< 1
Stockton Avenue Ventilation Structure	< 1	10	2	< 1	< 1
West Portal	1	36	7	1	< 1
East Portal	1	36	7	1	< 1
Tunnel (muck) – West Portal to East Portal	4	112	22	3	1
<b>Offsite Emissions (Concrete Truck exhaust): Twin-Bore and Single-Bore Options</b>					
Various Locations	1	16	3	< 1	< 1
<b>Total Twin-Bore Option</b>					
Maximum Daily Emissions – Unmitigated	21	252	143	10	9
Maximum Daily Emissions – Mitigated	5	74	142	2	1
BAAQMD Construction Significance Thresholds	54	54	—	82	54
Exceed Threshold?	No	Yes	—	No	No
<b>Total Single-Bore Option</b>					
Maximum Daily Emissions – Unmitigated	23	308	154	12	9
Maximum Daily Emissions – Mitigated	11	149	164	9	7
BAAQMD Construction Significance Thresholds	54	54	—	82	54
Exceed Threshold?	No	Yes	—	No	No
Source: ARB, EMFAC2014, CalEEMod version 2013. ROG = reactive organic gas; NO <sub>x</sub> = nitrogen oxides, CO = carbon monoxide; PM10 = particulate matter that is 10 microns in diameter or less; PM2.5 = particulate matter PM that is 2.5 microns in diameter or less					

The BART Extension includes avoidance, minimization, and mitigation measures to control fugitive dust (AQ-CNST-A) and reduce NO<sub>x</sub> emissions (AQ-CNST-B through



AQ-CNST-H; see below). These measures include Tier 3 equipment exhaust standards and idling limitations. Implementation of Tier 3 engine exhaust controls would reduce equipment-related NO<sub>x</sub> from 252 to approximately 93 pounds per day under the Twin-Bore Option and from 308 to 149 pounds per day under the Single-Bore Option. However, NO<sub>x</sub> emissions would still be greater than the BAAQMD significance threshold of 54 pounds per day. Therefore, construction air quality related to NO<sub>x</sub> emissions is considered an *adverse effect* for the BART Extension.

### **Mitigation Measure AQ-CNST-A: Implement Dust Control Measures**

VTA will require construction contractors to implement basic construction mitigation measures and additional construction mitigation measures recommended by BAAQMD to reduce fugitive dust emissions. Emission reduction measures will include the following applicable measures or similar performing measures (additional measures may be identified by BAAQMD or the contractor, as appropriate).

- All exposed surfaces (e.g., parking areas, staging areas, soil piles, graded areas, unpaved access roads) shall be watered two times per day or as needed to control dust. In times of drought, an effective combination of dust controls may be used in lieu of watering, such as soil binders/stabilizers, or watering may be used to form a crust on undisturbed areas.
- All exposed surfaces shall be watered at a frequency that will maintain a minimum soil moisture content of 12 percent. Moisture content can be verified by lab samples or a moisture probe, although such verification is typically visual. No visible dust emissions are permitted to leave the construction area.
- All haul trucks that transport soil, sand, or other loose material offsite shall be covered or moistened such that there are no dust emissions.
- All visible mud or dirt track-out onto adjacent public roads shall be removed using wet power vacuum street sweepers at least once per day, or more frequently if needed to control track-out during active soil hauling operations. The use of dry power sweeping is prohibited.
- All vehicle speeds on unpaved roads shall be limited to 15 mph.
- Paving operations on roadways, driveways, and sidewalks shall be completed as soon as possible. Building pads shall be laid as soon as possible after grading, unless seeding or a soil binder is used.
- A publicly visible sign shall be posted that includes the telephone number and name of the person to contact at VTA regarding dust complaints. This person shall respond and take corrective action within 48 hours. The BAAQMD phone number shall also be visible to ensure compliance with applicable regulations.
- All excavation, grading, and/or demolition activities shall be suspended when average wind speeds exceed 20 mph.

- Windbreaks (e.g., fences with screening) shall be installed on the windward side(s) of disturbed construction areas where feasible. Windbreaks should have 50 percent (maximum) air porosity.
- Vegetative ground cover (e.g., fast-germinating native grass seed) shall be planted in disturbed areas as soon as possible and watered appropriately until vegetation is established.
- The simultaneous occurrence of excavation, grading, and ground-disturbing construction activities in the same area shall be limited. Activities shall be phased to reduce the amount of disturbed surfaces at any one time.
- All trucks and equipment, including their tires, shall use designated construction entrances/exits that have been constructed with rock, rumble strips, or other features to remove dirt from tires.
- Sediment and erosion control devices shall be installed on sites with a slope greater than 1 percent to prevent silt runoff from entering public roadways.

**Mitigation Measure AQ-CNST-B: Use U.S. Environmental Protection Agency (EPA) Tier 4 or Cleaner Engines**

Construction contracts shall stipulate that all off-road, diesel-powered equipment used during construction will be equipped with EPA Tier 4 or cleaner engines, except for specialized construction equipment for which an EPA Tier 4 engine is not available. This mitigation measure assumes emission reductions compared with emissions from an average fleet-wide Tier 2 engine.

**Mitigation Measure AQ-CNST-C: Maintain Construction Equipment**

All construction equipment shall be maintained and properly tuned in accordance with the manufacturer's specifications. All equipment shall be checked by a certified mechanic and determined to be running in proper condition prior to operation.

**Mitigation Measure AQ-CNST-D: Minimize Idling Times**

Idling times shall be minimized, either by shutting equipment off when not in use or reducing the maximum idling time to 5 minutes (as required by California Airborne Toxic Control Measures, Title 13, Section 2485 of the California Code of Regulations). Clear signage shall be provided for construction workers at all access points.

**Mitigation Measure AQ-CNST-E: Use Equipment Meeting ARB Certification Standards**

All contractors shall use equipment that meets ARB's most recent certification standard for off-road heavy-duty diesel engines.

**Mitigation Measure AQ-CNST-F: Ensure Heavy-Duty Diesel Trucks Comply with EPA Emissions Standards**

Construction contracts shall stipulate that all on-road, heavy-duty diesel trucks with a gross vehicle weight rating of 19,500 pounds or greater will comply with EPA 2007 on-road emission standards for PM<sub>10</sub> and NO<sub>x</sub> (0.01 and 0.20 gram per brake horsepower hour, respectively). These PM<sub>10</sub> and NO<sub>x</sub> standards were phased in through the 2007 and 2010 model years on a percentage-of-sales basis (50 percent of sales from 2007 to 2009 and 100 percent of sales in 2010). This mitigation measure assumes that all on-road, heavy-duty diesel trucks will be model year 2010 and newer and compliant with EPA 2007 on-road emission standards.

**Mitigation Measure AQ-CNST-G: Use Low-Sulfur Fuel**

Low-sulfur fuel will be used (diesel with 15 parts per million or less) in all construction equipment.

**Mitigation Measure AQ-CNST-H: Locate Construction Areas Away from Sensitive Receptors**

Construction equipment and staging areas will be located away from sensitive receptors and fresh-air intake vents to buildings and air conditioners.

**Mitigation Measure AQ-CNST-I: Use Low-Volatile Organic Compound (VOC) Coatings**

All contractors shall use low-VOC (i.e., ROG) coatings that are beyond BAAQMD requirements (i.e., Regulation 8, Rule 3: Architectural Coatings [VOC content is limited to 100 grams per liter for flat coating and 150 grams per liter for non-flat coating]).

## 5.5.4 Biological Resources and Wetlands

Construction activities have the potential to disturb biological resources that are inside and outside the area of direct, permanent effect, including vegetative communities that provide habitat for special-status species and wetlands or other waters of the U.S. This section focuses on short-term effects from construction activities and mitigation measures to avoid or minimize these adverse effects. Refer to Chapter 4, Section 4.3, *Biological Resources and Wetlands*, for a description of the environmental setting, including potential for species to occur within or near the BART Extension.

### 5.5.4.1 Entire Alignment

Along the entire BART Extension alignment, construction activities would involve tree removal or pruning with the potential to result in adverse effects on nesting birds, if those activities occurred during the nesting season. Construction staging areas along the alignment require removal of trees and buildings. Roosting bats have the potential to occur in existing

buildings and trees requiring removal. The BART Extension Alternative would comply with San Jose's riparian setback policy, and therefore effects on nesting birds would be limited to street trees and urban trees. All construction activities and staging would occur outside of the riparian area, and therefore no effects on western pond turtles would occur. Noise and disturbance from heavy equipment and TBMs are not expected to disturb nesting birds and/or temporarily deter potentially occurring aquatic species such as central California coast steelhead, Chinook salmon, and western pond turtles from using aquatic sites because these activities would take place a minimum of 20 feet below the creekbed.

As described in Mitigation Measure AES-CNST-A (see Section 5.5.17, *Visual Quality and Aesthetics*), tree removal would comply with the overall intent and spirit of local tree ordinances as applicable.

Implementation of Mitigation Measures BIO-CNST-A, BIO-CNST-B, and BIO-CNST-C would minimize adverse effects on nesting birds, roosting bats, and wildlife movement or wildlife nursery sites during construction activities, including tree removal or pruning, and building demolition. This applies to both the Twin-Bore and Single-Bore Options.

#### **Mitigation Measure BIO-CNST-A: Avoid Nesting Bird Season**

To the extent feasible, construction (particularly tree removal and pruning) activities should be scheduled to avoid the bird nesting season (January 1–August 31). If such activities are scheduled to take place outside the nesting season, all effects on nesting birds, including raptors, protected under the Migratory Bird Treaty Act (MBTA) and California Fish and Game Code, should be avoided. The nesting season for most birds in Santa Clara County typically extends from February 1 through August 31, although some birds (e.g., raptors and hummingbirds) may nest as early as January 1 if a period of favorable weather persists.

#### **Mitigation Measure BIO-CNST-B: Conduct Preconstruction/Predisturbance Surveys for Nesting Birds**

If it is not possible to schedule construction activities that involve tree removal or pruning between September 1 and January 1, then preconstruction/predisturbance surveys for nesting birds will be conducted by a qualified biologist to ensure that no nests will be disturbed during construction activities. These surveys will be conducted no more than 48 hours prior to the initiation of construction. During each survey, a qualified biologist will inspect all potential nesting habitats (e.g., trees, shrubs, grasslands, and buildings) in accessible areas within 300 feet of impact areas for raptor nests and within 100 feet of impact areas for nests of non-raptors. If an active nest (i.e., a nest with eggs or young, or any completed raptor nest) is found sufficiently close to work areas to be disturbed by these activities, the biologist, in consultation with the California Department of Fish and Wildlife (CDFW), will determine the extent of a disturbance-free buffer zone to be established around the nest (typically 300 feet for raptors and 50 to 100 feet for other



species), to ensure that no nests of species protected by the MBTA and California Fish and Game Code will be disturbed as a result of construction activities.

### **Mitigation Measure BIO-CNST-C: Conduct Preconstruction Surveys for Roosting Bats and Implement Protective Measures**

#### *Trees*

If tree removal or trimming cannot be conducted between September 15 and October 30, qualified biologists will examine trees for suitable bat-roosting habitat before tree removal or trimming. High-quality habitat features (e.g., large tree cavities, basal hollows, loose or peeling bark, larger snags, palm trees with intact thatch) will be identified and the area around these features searched for bats and bat signs (e.g., guano, culled insect parts, staining). Riparian woodland, orchards, and stands of mature broadleaf trees are considered potential habitat for solitary foliage-roosting bat species. Because signs of bat use are not easily found, and trees cannot be completely surveyed for bat roosts, the protective measures listed below will be implemented for trees containing high-quality habitat features.

- Removal or disturbance of trees providing bat roosting habitat will be avoided between April 1 and September 15 (the maternity period) to avoid effects on pregnant females and active maternity roosts (whether colonial or solitary).
- Removal of trees providing bat roosting habitat will be conducted between September 15 and October 30, which corresponds to a time period when bats have not yet entered torpor or would be caring for nonvolant young (i.e., young that are unable to fly).
- Trees will be removed in pieces rather than felling an entire tree.
- If a maternity roost is found, whether solitary or colonial, that roost will remain undisturbed until September 15 or until a qualified biologist has determined the roost is no longer active.
- If avoidance of non-maternity roost trees is not possible, and tree removal or trimming must occur between October 30 and August 31, qualified biologists will monitor tree trimming/removal of the habitat. If possible, tree trimming or removal should occur in the late afternoon or evening when it is closer to the time that bats would normally arouse. Prior to trimming or removal of trees providing suitable roosting habitat, each tree will be shaken gently and several minutes should pass before felling trees or removing limbs to allow bats time to arouse and leave the tree. Biologists should search downed vegetation for dead and injured bats. The presence of dead or injured bats that are species of special concern will be reported to CDFW. The biologist will prepare a biological monitoring report, which will be provided to VTA and CDFW.

### ***Buildings***

Prior to the building removal or demolition, qualified biologists will conduct daytime surveys to assess the building(s) for potential bat roosting habitat, and to look for bats and bat sign. Qualified biologists will have knowledge of the natural history of the species that could occur and sufficient experience determining bat occupancy in buildings and bat survey techniques. The biologists will examine both the inside and outside of the buildings for potential roosting habitat, as well as routes of entry to the buildings. Locations of any roosting bats, signs of bat use, and entry and exit points will be noted and mapped on drawings of the buildings. Roost sites will also be photographed as feasible. The habitat assessment surveys should be conducted as far in advance of demolition as possible to allow time for planning and coordinating with CDFW, should bats be found. Depending on the results of the habitat assessment, the following steps will be taken.

- If the building(s) can be adequately assessed (i.e., all areas of the building can be examined) and no habitat or limited habitat for roosting bats is present and no signs of bat use are present, a preconstruction survey of the interior and exterior of the building(s) by qualified biologists will be conducted within 24 hours of demolition. If bats are found roosting during the preconstruction survey, CDFW will be contacted for direction on how to proceed.
- If moderate or high potential habitat is present but there are no signs of bat use, VTA will implement measures under the guidance of a qualified bat biologist to exclude bats from using the building(s) as a roost site, such as sealing off entry points. Prior to installing exclusion measures, qualified biologists will re-survey the building(s) to ensure that no bats are present. Additionally, a preconstruction survey of the interior and exterior of the building(s) will be conducted within 24 hours of demolition to confirm that no bats are present. If bats are found roosting during the preconstruction survey, CDFW will be contacted for direction on how to proceed.
- If moderate or high potential habitat is present and bats or bat sign are observed, or if exclusion measures are not installed as described above, or the building(s) provides suitable habitat but could not be adequately assessed, the following protective measures will be implemented.
  - Follow-up surveys will be conducted to determine if bats are still present. If species identification is required by CDFW, surveys using night vision goggles and active acoustic monitoring using full spectrum bat detectors will be used. A survey plan (number, timing, and type of surveys) will be determined in coordination with CDFW.
  - Based on the timing of demolition, the extent of bat sign or occupied habitat, and the species present (if determined), the qualified biologists will work with VTA and CDFW to develop a plan to discourage or exclude bat use prior to demolition.

The plan may include installing exclusion measures or using light or other means to deter bats from using the building to roost.

- A preconstruction survey of the interior and exterior of the building will be conducted within 24 hours of demolition.

Depending on the species of bats present, size of the bat roost, and timing of the demolition, additional protective measures may be necessary. Appropriate measures will be determined in coordination with the CDFW and may include measures listed below.

- To avoid effects on maternity colonies or hibernating bats, the building will not be demolished while bats are present, generally between April 1 and September 15 (maternity season) and from October 30 to March 1 (hibernation).
- Removal of roosting habitat will only occur following the maternity season and prior to hibernation, generally between September 15 and October 30, unless exclusionary devices are first installed (as described below). Other measures, such as using lights to deter bat roosting, may be used if developed in coordination with and approved by CDFW.
- Installation of exclusion devices will occur before the maternity season and prior to hibernation, generally from March 1–30 or September 15–October 30 to preclude bats from occupying a roost site during demolition. Exclusionary devices will only be installed by or under the supervision of an experienced bat biologist.

CDFW may require compensatory mitigation for the loss of roosting habitat depending on the species present and size of the bat roost. Compensation, if required, will be determined in consultation with CDFW, and may include construction and monitoring of suitable replacement habitat on or near the BART Extension site.

#### **5.5.4.2 Connection to Phase I Berryessa Extension**

The connection to Phase I Berryessa Extension would be at grade near Las Plumas Avenue, north of Lower Silver Creek, and then enter the East Tunnel Portal. Approximately 900 feet south of the portal, the tunnel would pass beneath Lower Silver Creek near the U.S. 101 crossing. Tunnel boring would occur underground, and there would be no construction activities near Lower Silver Creek. Nesting birds have the potential to occur in street or urban trees and could be affected if tree removal or pruning occurred during the nesting season. Roosting bats have the potential to occur in existing buildings and trees in construction staging areas that would be removed. However, implementation of Mitigation Measures BIO-CNST-A, BIO-CNST-B, and BIO-CNST-C would ensure there would be *no adverse effects* on special-status species or habitat for both the Twin-Bore and Single-Bore Options.

#### **5.5.4.3 Alum Rock/28<sup>th</sup> Street Station**

Alum Rock/28<sup>th</sup> Street Station would be in an area that is already urbanized. The nesting bird and bat discussion and mitigation provided above under Section 5.5.4.2, *Connection to Phase 1 Berryessa Extension*, also applies to this station. Therefore, there would be *no adverse effect* related to biological resources and wetlands.

#### **5.5.4.4 Tunnel Alignment from Alum Rock/28<sup>th</sup> Street Station to Downtown San Jose Station**

Tunnel boring would occur between approximately 20 and 55 feet below the Coyote Creek bed, and all construction activities in this area would occur entirely underground. The only construction staging location is at the 13<sup>th</sup> Street ventilation structure, which is in an already disturbed and urban area. The nesting bird and bat discussion and mitigation provided above under Section 5.5.4.2, *Connection to Phase 1 Berryessa Extension*, also applies to this tunnel alignment section. No other effects on special-status species or habitat are expected to result from construction of this section. The alignment under the Twin-Bore Option would veer slightly to the north of the alignment for the Single-Bore Option near Coyote Creek; however, effects would be similar for both options. Therefore, there would be *no adverse effect* related to biological resources and wetlands.

#### **5.5.4.5 Downtown San Jose Station (East and West Options)**

Both the East and West Options of the Downtown San Jose Station would be in a Downtown commercial area with high human disturbance. The Twin-Bore Option involves a major cut-and-cover construction activity and the use of heavy construction equipment for construction of the station and crossover. The nesting bird and bat discussion and mitigation provided above under Section 5.5.4.2, *Connection to Phase 1 Berryessa Extension*, also applies to this station. No other effects on special-status species or habitat are expected to result from construction of this station. Therefore, there would be *no adverse effect* under the Twin-Bore Option.

The Single-Bore Option would only have aboveground construction activities for the entrances and system facilities. The nesting bird and bat discussion and mitigation provided above under Section 5.5.4.2, *Connection to Phase 1 Berryessa Extension*, also applies to this option. Therefore, there would be *no adverse effect* under the Single-Bore Option.

#### **5.5.4.6 Diridon Station (South and North Options)**

Prior to reaching the Diridon Station South and North Options, the alignment would cross at least 45 feet and 40 feet below the Guadalupe River bed, respectively. Tunnel boring under the Guadalupe River would not disturb special-status bats in the riparian area, western pond turtles, or Central California coast steelhead and Chinook salmon. Construction staging under State Route (SR) 87 could adversely affect riparian habitat; however, the BART Extension would comply with the City of San Jose's riparian setback policy by avoiding the riparian



area and would not affect special-status species. Additionally, implementation of Mitigation Measure BIO-CNST-D below would further minimize any effect on riparian habitat and special-status species.

For the Diridon Station South Option, the Twin-Bore and Single-Bore Options would be approximately 20 feet and 50 feet below the Los Gatos Creek bed, respectively. Aboveground system facilities proposed at the Diridon Station South Option (both the Twin-Bore and Single-Bore Options) would be constructed adjacent to Los Gatos Creek. For the Diridon Station North Option, the Twin-Bore and Single-Bore Options would occur approximately 25 feet and 50 feet below the Los Gatos Creek bed, respectively, and the aboveground system facilities would be located west of Autumn Street. The Diridon Station North Option would also utilize a previously disturbed, triangular parcel for construction staging and/or underground station system facilities (Single-Bore Option) adjacent to the west of the Caltrain tracks. Construction activities adjacent to Los Gatos Creek could have an adverse effect on riparian habitat. However, as discussed above, the BART Extension would comply with the City of San Jose's riparian setback policy and implement Mitigation Measure BIO-CNST-D to avoid effects on riparian habitat.

The nesting bird and bat discussion and mitigation provided above under Section 5.5.4.2, *Connection to Phase 1 Berryessa Extension*, also applies to the Diridon Station South and North Options.

Along the Guadalupe River and Los Gatos Creek, tricolored blackbird surveys are required under the Santa Clara Valley Habitat Plan (SCVHP) and would be conducted before construction commences, as described in Mitigation Measure BIO-CNST-E below. Avoidance and minimization measures and biological monitoring would be determined and established if individuals are found. As discussed in Chapter 6, Section 6.154, *Water Resources, Water Quality, and Floodplains*, as part of compliance with the Construction General Permit, standard erosion control measures and other best management practices would be identified in a Storm Water Pollution Prevention Plan. Therefore, at the Diridon Station South and North Options, there would be *no adverse effect* with the implementation of mitigation measures.

### **Mitigation Measure BIO-CNST-D: Protect Riparian Habitat**

VTA will design all BART Extension facilities to avoid temporary and permanent adverse effects on riparian habitat. Riparian forest areas identified along the Guadalupe River and Los Gatos Creek will be identified on the plans as environmentally sensitive areas and marked with protective orange fencing or flagging during construction to avoid disturbance or accidental intrusion by workers or equipment. Night lighting from construction activities and staging will not occur in the riparian area.

### **Mitigation Measure BIO-CNST-E: Conduct Preconstruction Tricolored Blackbird Nesting Surveys and Determine Appropriate Action**

There are and have been no known tricolored blackbird nesting colonies in the BART Extension area within the last 5 years. However, to avoid direct effects of construction activities on potential nesting tricolored blackbird colonies, the following procedures will be implemented. This mitigation measure incorporates survey, avoidance, and minimization guidelines taken directly from Condition 17 of the SCVHP (Santa Clara County 2012).

A qualified biologist will conduct a field investigation to identify and map potential nesting substrate. Nesting substrate generally includes flooded, thorny, or spiny vegetation (e.g., cattails, bulrushes, willows, blackberries, thistles, or nettles). If potential nesting substrate is found, VTA may revise the construction staging areas to avoid all areas within a 250-foot buffer around the potential nesting habitat, and surveys will be conducted. If VTA chooses not to avoid the potential nesting habitat and the 250-foot buffer, additional nesting surveys will be required.

Prior to any ground disturbance related to BART Extension activities, a qualified biologist will perform the following:

1. Make his/her best effort to determine if there has been nesting at the site in the past 5 years. This includes checking the California Natural Diversity Database (CNDDDB), contacting local experts, and looking for evidence of historical nesting (i.e., old nests).
2. If no nesting in the past 5 years is evident, conduct a preconstruction survey in areas identified in the habitat survey as supporting potential tricolored blackbird nesting habitat. Surveys will be made at the appropriate times of year when nesting use is expected to occur. The surveys will document the presence or absence of nesting colonies of tricolored blackbird. Surveys will conclude no more than two calendar days prior to construction.

To avoid last minute changes in schedule or contracting that may occur if an active nest is found, VTA may also conduct a preliminary survey up to 14 days before construction commences. If a tricolored blackbird nesting colony is present (through step 1 or 2 above), a 250-foot buffer will be applied from the outer edge of all hydric vegetation associated with the site, and the site plus buffer will be avoided (see below for additional avoidance and minimization details). CDFW, the U.S. Fish and Wildlife Service (USFWS), and the Santa Clara Valley Habitat Agency (SCVHA) will be notified immediately of nest locations.

#### ***Avoidance and Minimization***

Construction activities must avoid tricolored blackbird nesting habitat that is currently occupied or that has been used in the past 5 years. If tricolored blackbird colonies are

identified during the breeding season, construction activities will be prohibited within a 250-foot no-activity buffer zone around the outer edge of all hydric vegetation associated with the colony. This buffer may be reduced in areas with dense forest, buildings, or other habitat features between the construction activities and the active nest colony, or where there is sufficient topographic relief to protect the colony from excessive noise or visual disturbance.

Depending on site characteristics, the sensitivity of the colony, and surrounding land uses, the buffer zone may be increased. Land uses potentially affecting a colony will be observed by a qualified biologist to verify that the activity is not disrupting the colony. If it is, the buffer will be increased. VTA staff will coordinate with CDFW, USFWS, and SCVHA and evaluate exceptions to the minimum no-activity buffer distance on a case-by-case basis.

### ***Construction Monitoring***

If construction takes place during the breeding season when an active colony is present, a qualified biologist will monitor construction to ensure that the 250-foot buffer zone is enforced. If monitoring indicates that construction outside of the buffer is affecting a breeding colony, the buffer will be increased if space allows (e.g., move staging areas farther away). If space does not allow, construction will cease until the colony abandons the site or until the end of the breeding season, whichever occurs first. The biological monitor will also conduct training of construction personnel on the avoidance procedures, buffer zones, and protocols in the event that tricolored blackbirds fly into an active construction zone (i.e., outside the buffer zone).

#### **5.5.4.7 Continuation of Tunnel Alignment from the Diridon Station to Newhall Maintenance Facility**

The continuation of the tunnel alignment would be in an urbanized area with extensive human disturbance. The ventilation structure locations along Stockton Avenue would be in a highly urbanized area with no onsite habitat. The nesting bird and bat discussion and mitigation provided above under Section 5.5.4.2, *Connection to Phase I Berryessa Extension*, also applies to this tunnel alignment for both the Twin-Bore and Single-Bore Options. No other effects on special-status species or habitat are expected to result from construction of this station. Therefore, there would be *no adverse effect* related to biological resources and wetlands.

#### **5.5.4.8 Newhall Maintenance Facility**

The Newhall Maintenance Facility would be in an urbanized area with extensive human disturbance. In addition, over 100 trains per day use the railroad tracks immediately to the south. However, the SCVHP has designated the area within the City of San Jose as occupied nesting burrowing owl habitat and a burrowing owl survey area (Santa Clara County 2016). The five documented occurrences within 2 miles of the Newhall Maintenance Facility are all

at the Mineta San Jose International Airport. The potential for burrowing owls to be at the site is moderate as much of the site does not offer suitable foraging habitat. However, construction activities could have an adverse effect on burrowing owls if they occur in the ruderal habitats in the area. Implementation of Mitigation Measure BIO-CNST-F would ensure there would be *no adverse effects* on burrowing owls.

Tree removal and pruning and building removal for construction activities and staging could have an adverse effect on nesting birds and roosting bats. However, implementation of Mitigation Measures BIO-CNST-A, BIO-CNST-B, and BIO-CNST-C would ensure there would be *no adverse effects* on nesting birds and roosting bats. No other special-status species are expected to be present in this area.

### **Mitigation Measure BIO-CNST-F: Conduct Preconstruction Burrowing Owl Surveys and Determine Appropriate Action**

To avoid or minimize direct effects of construction activities on burrowing owls, the procedures described below will be implemented. This mitigation measure incorporates survey, avoidance, and minimization guidelines taken directly from Condition 15 of the SCVHP (SCVHA 2012).

Prior to any ground disturbance related to BART Extension Alternative activities, a qualified biologist will conduct preconstruction surveys in all suitable habitat areas as identified by SCVHA. The purpose of the preconstruction surveys is to document the presence or absence of burrowing owls on the construction site, particularly in areas within 250 feet of construction activity.

To maximize the likelihood of detecting owls, the preconstruction survey will last a minimum of 3 hours. The survey will begin 1 hour before sunrise and continue until 2 hours after sunrise (3 hours total) or begin 2 hours before sunset and continue until 1 hour after sunset. Additional time may be required since this is a large construction sites. A minimum of two surveys will be conducted (if owls are detected on the first survey, a second survey is not needed). All owls observed will be counted and their location will be mapped.

Surveys will conclude no more than 2 calendar days prior to construction. Therefore, the project proponent must begin surveys no more than 4 days prior to construction (2 days of surveying plus up to 2 days between surveys and construction). To avoid last minute changes in schedule or contracting that may occur if burrowing owls are found, VTA may also conduct a preliminary survey up to 14 days before construction. This preliminary survey may count as the first of the two required surveys as long as the second survey concludes no more than 2 calendar days in advance of construction.

In order to allow covered activities to go forward in burrowing owl habitat, VTA will employ avoidance measures described below to ensure that direct take does not occur.



## *Avoidance Measures*

### *Breeding Season*

If evidence of burrowing owls is found during the breeding season (February 1–August 31), VTA will avoid all nest sites that could be disturbed by construction during the remainder of the breeding season or while the nest is occupied by adults or young (occupation includes individuals or family groups foraging on or near the site following fledging). Avoidance will include establishment of a 250-foot non-disturbance buffer zone around nests. Construction may occur outside of the 250-foot non-disturbance buffer zone. Construction may take place inside of the 250-foot non-disturbance buffer during the breeding season if the following occurs:

- The nest is not disturbed, and
- VTA develops an avoidance, minimization, and monitoring plan that will be reviewed by CDFW, USFWS, and SCVHA prior to construction based on the following criteria:
  - CDFW, USFWS, and the SCVHA approves the avoidance and minimization plan provided by VTA.
  - A qualified biologist monitors the owls for at least 3 days prior to construction to determine baseline nesting and foraging behavior (i.e., behavior without construction).
  - The same qualified biologist monitors the owls during construction and finds no change in owl nesting and foraging behavior in response to construction activities.
  - If there is any change in owl nesting and foraging behavior as a result of construction activities, these activities will cease within the 250-foot buffer. Construction cannot resume within the 250-foot buffer until the adults and juveniles from the occupied burrows have moved out of the construction area.
  - If monitoring indicates that the nest is abandoned prior to the end of the nesting season and the burrow is no longer in use by owls, the non-disturbance buffer zone may be removed. The biologist will excavate the burrow to prevent reoccupation after receiving approval from CDFW, USFWS, and SCVHA.

CDFW, USFWS, and SCVHA will have 21 calendar days to respond to a request from VTA to review the proposed construction monitoring plan. If these parties do not respond within 21 calendar days, it will be presumed that they concur with the proposal and work can commence.

### *Non-Breeding Season*

During the non-breeding season (September 1–January 31), VTA will establish a 250-foot non-disturbance buffer around occupied burrows as determined by a qualified

biologist. Construction activities outside of this 250-foot buffer are allowed. Construction activities within the non-disturbance buffer are allowed if the following criteria are met in order to prevent owls from abandoning important overwintering sites.

- A qualified biologist monitors the owls for at least 3 days prior to construction to determine baseline foraging behavior (i.e., behavior without construction).
- The same qualified biologist monitors the owls during construction and finds no change in owl foraging behavior in response to construction activities.
- If there is any change in owl nesting and foraging behavior as a result of construction activities, these activities will cease within the 250-foot buffer.
- If the owls are gone for at least 1 week, VTA may request approval from CDFW, USFWS, and SCVHA for a qualified biologist to excavate usable burrows to prevent owls from re-occupying the site. After all usable burrows are excavated, the buffer zone will be removed and construction may continue.

Monitoring must continue as described above for the non-breeding season as long as the burrow remains active.

### ***Construction Monitoring***

Based on the avoidance, minimization, and monitoring plan developed (as required above), during construction, the non-disturbance buffer zones will be established and maintained if applicable. A qualified biologist will monitor the site consistent with the requirements described above to ensure that buffers are enforced and owls are not disturbed. The biological monitor will also conduct training of construction personnel on the avoidance procedures, buffer zones, and protocols in the event that a burrowing owl flies into an active construction zone. With implementation of the above mitigation measures, there would be no adverse effect related to biological resources and wetlands.

#### **5.5.4.9 Santa Clara Station**

The Santa Clara Station would be in an area that is already heavily urbanized. The nesting bird and bat discussion and mitigation provided above under Section 5.5.4.2, *Connection to Phase 1 Berryessa Extension*, also applies to this station. No other effects on special-status species or habitat are expected to result from construction of this station. Therefore, there would *be no adverse effect* related to biological resources and wetlands.

### **5.5.5 Community Facilities and Public Services**

The BART Extension Alternative would be constructed primarily in tunnels beneath existing city streets and public property. In addition, a number of construction staging areas (CSAs) would be required for vehicle parking, construction equipment storage and usage, and materials storage. For a list of public services and community facilities located within 0.25 mile (as the crow flies) of the alignment and CSAs, refer to Table 4.4-1 in Chapter 4,

Section 4.4, *Community Facilities and Public Services*. These facilities may be affected by construction-related noise, vibration, and traffic disruption.

Construction traffic around the CSAs may cause temporary access interruptions resulting from detours or street closures in the vicinity. The primary effect would be the need for emergency vehicles to observe any short-term closures and temporary construction detours.

Mitigation Measure TRA-CNST-A through TRA-CNST-D provide for coordination with local businesses including event venues like SAP, local community facilities, and emergency provider such that disruption to community events and emergency responders can be minimized (see Section 5.5.1, *Construction Education and Outreach Plan*).

Construction would result in *no adverse effect* on existing community facilities and services.

## 5.5.6 Cultural Resources

### 5.5.6.1 Archaeological Impacts

#### **Known Resource CA-SCL-363H (CA-SCL-363H/P-43-000369)**

The background records search conducted for the BART Extension identified one archaeological resource within the archaeological Area of Potential Effects (APE). This resource, CA-SCL-363H/P-43-000369 (hence referred to as CA-SCL-363H), a historical archaeological resource, contains archaeological features associated with the Spanish Period Amesquita Adobe as well as Late American commercial and residential features, some of which are possibly associated with one of the city's post-1877 Chinatowns. It encompasses a part of the city's original Pueblo San Jose de Guadalupe, which was established in 1777. Most of the site is considered eligible for listing to the National Register of Historic Places (NRHP) under Criteria A and D, although that portion underlying SR 87 is not considered contributing to the eligibility for listing on the NRHP due to prior extensive disturbance from construction of SR 87 and channelization of Guadalupe River, with State Historic Preservation Officer (SHPO) concurrence (Mellon 2003). A detailed description of CA-SCL-363H is provided in Section 4.5.2.2. BART Extension elements located within proximity of CA-SCL-363H, which include the TBM-constructed tunnel below the resource and the aboveground construction staging area, and their potential impacts on the CA-SCL-363H are described below.

#### **Construction of the Tunnel**

Where the tunnel alignment passes under CA-SCL-363H, the tunnel would be excavated by a TBM with a minimum distance between ground surface and the top of the TBM of approximately 45–55 feet for the Twin-Bore Option and approximately 65–70 feet for the Single-Bore Option. This is well below any potential buried deposits associated with this historic-period site. Therefore, construction of the tunnel, under either the Twin-Bore or Single-Bore Option, would not result in the partial removal of, physical destruction of, or

damage to the historic property under Code of Federal Regulations (CFR), Title 36, Sections 800.5(a)(2)(i), (ii) and (iii).

A *Noise and Vibration Technical Report* was prepared for the BART Extension (Wilson, Ihrig 2016), in which data were based on criteria defined in FTA's *Transit Noise and Vibration Impact Assessment*, also referred to as the FTA Guidance Manual. The *Noise and Vibration Technical Report* calculated the anticipated vibration levels from construction of the tunnel by a TBM. The crown (top) of the tunnel would be approximately 50 feet below ground surface for the Twin-Bore Option and approximately 70 feet below ground surface for the Single-Bore Option. For both options, the anticipated vibration levels (measured as peak particle velocity [PPV]) caused by the TBM would not exceed 0.02 inch/second at the site of the Amesquita Adobe foundations, which is substantially below the most conservative building damage criterion of 0.12 inch/second. Therefore, construction vibration levels would not exceed acceptable criteria, and construction of the tunnel by TBM would result in *no adverse effect* on the Amesquita Adobe foundation preserved in CA-SCL-363H.

### **Aboveground Construction Staging Area**

A CSA would be located south of Santa Clara Street and directly under the elevated SR 87 roadway at ground surface, as shown in Figures 5-7 and 5-8. This CSA is located within the boundaries of CA-SCL-363H, but is west of the Amesquita Adobe foundations and within an area that was previously determined not to be a contributing part of the historic resource, with SHPO concurrence.

Within this CSA, activities would include mainly storage of construction equipment and materials. The area within the CSA is currently covered by an existing paved parking lot. Excavation is not anticipated in this CSA, and no aboveground structures would need to be demolished here. Lastly, because the CSA would be within a part of the historic site that was previously determined not to have elements that contribute to its eligibility, the CSA under SR 87 would not affect the elements of CA-SCL-363H that contribute to its eligibility in the NRHP. Therefore, the CSA would result in *no adverse effect* on the contributing elements of this historic property that make it eligible for the NRHP.

### **Conclusion**

As described above, construction of the BART Extension Alternative would have *no adverse effect* on the one known archaeological resource within the APE, CA-SCL-363H; therefore, no mitigation is required. No other known prehistoric or historic-era archaeological sites, features, artifacts, or human remains have been documented within the APE. The analysis of long-term impacts on cultural resources resulting from operation of the BART Extension Alternative is discussed in Section 4.5.4.2.

### **Unknown Resources**

As discussed in Section 4.5, the 2016 *Archaeological Resources Technical Report* (ARTR) identified numerous locations within the APE where archaeological resources are known to



exist or may be expected. Whether those resources qualify as significant under Section 106 of the National Historic Preservation Act cannot be determined without further research and testing. Preconstruction archaeological testing is recommended to test the sensitive areas within the APE that may be disturbed by construction of the BART Extension. However, many of the sensitive areas are located under existing buildings or infrastructure that would have to be removed prior to testing, are located on private property, or both. Therefore, it is not feasible to test all sensitive areas, or determine the effects on potential historic properties, at this time.

Consequently, a Draft Programmatic Agreement (PA) has been prepared for the identification and evaluation of archaeological resources in phases prior to construction of the project, and treatment of archaeological resources and burials in the event that such resources are discovered during construction activities. The Draft PA includes an outline for an Archaeological Resources Treatment Plan (ARTP) that will be prepared. The ARTP will describe archaeological procedures, notification and consultation requirements, professional qualifications requirements, and procedures for the disposition of artifacts if any are discovered.

Implementation of Mitigation Measure CUL-CNST-A would minimize and avoid potential adverse effects on unknown archaeological resources, resulting in *no adverse effect* on cultural resources.

### **Mitigation Measure CUL-CNST-A: Implement Programmatic Agreement and Archaeological Resources Treatment Plan**

A Programmatic Agreement (PA) and a supporting Archaeological Resources Treatment Plan (ARTP) will be developed and executed by VTA in consultation with interested Native Americans, the California SHPO, the Advisory Council on Historic Preservation, and historic preservation societies such as the South Bay Historical Railroad Society; and will be implemented prior to construction of the BART Extension.

The ARTP will specify the NRHP criteria that are applicable, the procedures to be used to implement the Section 106 process in the field, and the standards of evaluation that will be appropriate given the locations and kinds of cultural properties predicted. The ARTP will present methods that combine pre-testing where possible (i.e., on open lots or undeveloped lands); testing after demolition of extant structures but before new ground-disturbing construction begins; construction-phase monitoring where appropriate; and standards for data recovery. Areas within the APE where potential resources have been identified, or that are designated as highly or moderately sensitive, will be field investigated, concentrating on, but not confined to, the area of direct effect. The ARTP will meet The Secretary of the Interior's Standards and Guidelines for Archaeology and Historic Preservation (U.S. Department of the Interior, National Park Service, 1983, as amended and annotated).

### 5.5.6.2 Historic Architecture Impacts

Construction of the BART Extension Alternative would not cause any adverse effect on any of the 29 identified historic properties (see Tables 4.5-1 through 4.5-3 in Chapter 4, Section 4.5, *Cultural Resources*). BART Extension components near historic properties include tunnel alignments, stations (Alum Rock/28<sup>th</sup> Street, Downtown San Jose—East and West Options, Diridon—South and North Options, and Santa Clara), and the Newhall Maintenance Facility.

#### Direct Adverse Effects

None of the BART Extension Alternative components, including the above-ground connection to the Phase I Berryessa Extension, tunnel portals, or ventilation or electrical facilities, would result in a *direct* adverse effect on any of the 29 identified historic properties because they would not result in physical demolition, destruction, relocation, or alteration of any historic property.

#### Alum Rock/28<sup>th</sup> Street Station

One historic property, the Church of Five Wounds near Alum Rock/28<sup>th</sup> Street Station, is across the street from the proposed station; therefore, the station is outside of the historic property boundary and its construction would not result in the partial removal of, physical destruction of, or damage to this historic property.

#### Downtown San Jose Station East and West Options

Although some elements of the Downtown San Jose Station East and West Options, such as station entrance portals and elevators, would be within the boundary of the San Jose Downtown Commercial District, and may alter the landscaping, infrastructure, and hardscape (i.e., sidewalks, curbs, light standards, and street furniture) within the public ROW at those locations, these features have been altered and/or replaced over time and are not considered contributing elements of the district. Given the size of the historic district (28 contributing structures in total located within a more than two-square-block area over 11 acres), and that there are only three locations under the West Option, and one location under the East Option, where station entrance portals or elevators would be within or immediately adjacent to the historic district, any potential alteration of the streetscape features within the public ROW would not present an adverse change to the overall historic district. The entrance portals and elevators are small in scale relative to the surrounding buildings, and massing would be consistent with the character of the commercial district and existing transportation corridors. Set in a dense urban setting, the historic district has already been altered by the construction of modern (i.e., not dating to the historic district's period of significance) buildings, structures, and infrastructure, including the addition and/or replacement of light standards, mailboxes, signage, traffic and pedestrian lights, bus shelters, parking meters, and sidewalk improvements. The historic integrity of the historic district and its contributors, including

those that are adjacent to entrance portals and elevators, would remain unchanged. Therefore, these BART Extension elements would result in *no adverse effect*.

Under the Downtown San Jose Station West Option, a station entrance portal is proposed within a vacant lot, currently used as a parking lot, adjacent to 81 Santa Clara Street, which is individually eligible for the NRHP. The station entrance would include an elevator, stairs, and escalators set back from Santa Clara Street behind a glass façade approximately 160 feet long. However, the glass façade of the entrance would be free standing and set back slightly from the façade of the historic property. The historic integrity of the property would remain unchanged, and the significance of this historical resource would not be materially impaired; therefore, there would be *no direct adverse effect* on the historic building from the construction of this station.

### **Diridon Station South Option**

Components of the Diridon Station South Option under both the Twin-Bore and Single-Bore Options (including a reconstructed bus transit center, station entrance portal, and tunnel ventilation, emergency exhaust ventilation, and fresh air shafts) would be located within the boundary of the historic Cahill Station. These features would be in an area already altered by the extant transit center and would be a considerable distance away (approximately 50 or more feet) from the key contributors (depot, wrought-iron fencing, tracks, and passenger sheds). These BART Extension elements would not cause the partial removal of, physical destruction of, or damage to any contributing elements of the historic property. Construction of these elements would not cause the partial removal of, physical destruction of, or damage to any contributing elements of the historic property. The historic use and integrity of the historic property would be unchanged. Therefore, these BART Extension elements would result in *no adverse effect*.

### **Diridon Station North Option**

Portions of the Diridon Station North Option (Twin-Bore and Single-Bore Options) would be located within the boundary of the historic Cahill Station, which is listed in the NRHP. These above-ground features, including a reconstructed bus transit center, station entrance portal, and tunnel ventilation, emergency exhaust ventilation, and fresh air shafts, would be in an area already altered by the extant transit center and would be approximately 20 or more feet away from the depot, wrought-iron fencing, tracks, passenger sheds, and undercrossing, all of which contribute to the significance of this historic property. Construction of these BART Extension elements would not cause the partial removal of, physical destruction of, or damage to any contributing elements of the historic property. The historic use and integrity of the historic property would be unchanged, and there would be *no adverse effects*.

### **Newhall Maintenance Facility**

Two historic properties are adjacent to the Newhall Maintenance Facility; however, construction of the maintenance facility would not result in the partial removal of, physical

destruction of, or damage to these two historic properties. Therefore, there would be *no adverse effects*.

### **Santa Clara Station**

The Santa Clara Station would be east of the maintenance facility and farther away (more than 150 feet) from the historic properties than the maintenance facility; therefore, construction of the station would not result in the partial removal of, physical destruction of, or damage to these two historic properties, and there would be *no adverse effects*.

### **Indirect Adverse Effects**

The BART Extension Alternative would also not result in any *indirect* adverse change to the identified historic properties from construction of the tunnel, stations (Alum Rock/28<sup>th</sup> Street, Downtown San Jose—East and West Options, Diridon—South and North Options, and Santa Clara), or the Newhall Maintenance Facility. Indirect impacts on historic properties may be caused by the introduction of new noise and vibration, ground settlement, and visual elements from construction of the BART Extension Alternative.

### **Noise and Vibration Impacts**

There would be no indirect adverse effect on any historic property from predicted vibration or noise impacts from the construction of the BART Extension Alternative at the location of any historic property. While the *Noise and Vibration Technical Report* concludes that impacts cause by vibration from construction of the BART Extension may exceed the FTA threshold of 0.12 inch/second PPV for potential to cause physical damage or alteration on historic properties, the contractor would be required to maintain vibration levels of less than 0.12 inch/second PPV as measured at historic properties to avoid adverse effects. Therefore, a comprehensive and detailed Vibration Monitoring Plan as outlined in Mitigation Measures NV-CNST-P through NV-CNST-R (see Section 5.5.13.3) will be developed prior to construction to monitor vibration levels near historic properties during construction. The Vibration Monitoring Plan will include the following:

- Conduct preconstruction photo and/or video survey of buildings that are sensitive to vibration, such as historic structures.
- Determine which buildings will be monitored for vibration during construction.
- Determine what activities are to be monitored and establish the limits for vibration to avoid adverse effects to historic properties.
- Develop a protocol for monitoring of existing cracks in buildings.

In addition, any inadvertent damage caused to any historic property from BART Extension construction vibration (should it occur) would be repaired in accordance with the Secretary of the Interior's *Standards for the Treatment of Historic Properties*. Implementation of these measures would minimize and/or avoid construction vibration impacts on historic properties. Implementation of these measures would minimize and/or avoid construction vibration



impacts on historic properties. Therefore, there are no anticipated indirect adverse effects on historic properties from BART Extension construction vibration.

Construction noise has the potential to cause indirect adverse effects only on historic properties that have an inherent quiet quality that is part of a property's historic character and significance (i.e., churches, parks, and National Historic Landmarks with significant outdoor use). Only one of the 29 historic properties, the Church of Five Wounds is considered to have an inherent quiet quality. Impacts from construction of the underground station box for the Alum Rock/28<sup>th</sup> Street Station is anticipated to produce noise levels above the FTA threshold of 85 A-weighted decibels (dBA) at the location of a school building, a contributing building within this historic property. However, application of mitigation measures would avoid adverse effects on this historic property. Mitigation identified in Section 5.5.13.3 includes installation of a temporary noise wall or noise curtain (a flexible barrier hung from frames) (Mitigation Measure NV-CNST-C) and restriction on noise-generating construction activity hours (Mitigation Measure NV-CNST-H). The temporary noise or curtain wall would be high enough to block equipment generating noise and result in an anticipated 5 dBA reduction in construction noise level. Implementation of these avoidance/minimization efforts would avoid indirect adverse effects to this historic property.

All other historic properties, which consist of commercial, transportation, industrial, and residential resources, do not have an inherent quiet quality that is part of their historic character or significance; therefore, the BART Extension Alternative would result in *no indirect adverse effects* on those 28 historic properties from construction noise.

### **Surface Settlement during Construction**

As described in the *Geotechnical Memorandum* prepared for the Phase II Project by Parikh Consultants (February 2014), there may be surface settlement from construction of the tunnel with a TBM or with cut-and-cover construction of the stations (Twin-Bore Option only), station entrances, tunnel portals, and mid-tunnel ventilation structures. Construction of the Twin-Bore Option could result in a maximum settlement of approximately 0.50 inch occurring at the centerline between the two bores, while the maximum predicted settlement for the Single-Bore Option would be 1 inch. For cut-and-cover construction, surface settlement would vary with distance from the excavation, with a maximum, approximately 1.4 inches, at areas adjacent to open cut-and-cover excavations. Ground-settlement reduction techniques, such as pressurized closed-face TBM, the addition of conditioning agents to the soils around the face of the TBM, and use of a combination of soil-cement mix or slurry diaphragm walls, ground treatment, strengthening of structures, and underpinning of structures, would be implemented during construction around historic properties to minimize surface settlement.

With the use of aboveground-settlement reduction methods during construction, the BART Extension Alternative is not anticipated to cause indirect adverse effects on any historic properties. However, to ensure no inadvertent adverse damage from ground settlement from construction would affect historic properties, pre- and post-construction condition surveys (as

outlined in Mitigation Measures GEO-CNST-B through GEO-CNST-D in Section 5.5.9.2) would be conducted, following industry best practices, on historic buildings that are determined to be sensitive to ground settlement. In addition, monitors would be installed prior to and during construction at select historic structures to monitor ground movements and the effects of tunnel boring and cut-and-cover activities on these sensitive structures. Monitoring can be used to direct real-time adjustments to construction techniques and methods to minimize ground settlement at a given location.

Pre- and post-construction building assessments would be conducted by independent surveyors for selected historic buildings along the alignment to assess the conditions of the properties (as outlined in Mitigation Measures GEO-CNST-B through GEO-CNST-D). The preconstruction assessment will determine which historic buildings are considered sensitive, and therefore susceptible to potential damage from ground settlement, and would require further post-construction building assessment and/or monitoring during construction. In addition, any inadvertent damage caused to any historic property from construction (should it occur) would be repaired in accordance with the *Standards for the Treatment of Historic Properties*. With the implementation of the requirements listed above, ground settlement under and around historic structures would be minimized and/or avoided; thus, *no indirect adverse effect* resulting from ground settlement during construction is anticipated.

Long-term, operational effects from the BART Extension on historic properties within the BART Extension APE are described in Chapter 4, Section 4.5, *Cultural Resources*.

### **Visual Impacts**

The construction activities at construction staging areas would temporarily alter visual settings. The most visible construction activities would be at the parking garages at the Alum Rock/28<sup>th</sup> Street and Santa Clara Stations that are near historic buildings. This would involve cranes, framing of the structures, and other construction activities not unlike other major building construction in downtown areas. The cut-and-cover Downtown San Jose and Diridon Stations (Twin-Bore Option only) would also involve major construction activities; however, these sites would only be visible from adjacent areas temporarily until Santa Clara Street is restored for use. Because construction activities are short term, the BART Extension would result in *no indirect adverse effect* on historic buildings.

## **5.5.7 Electromagnetic Fields and Electromagnetic Interference**

There would be no electromagnetic field (EMF)-related effects associated with the BART Extension during construction. Construction activities typically would not involve the use of major electrical systems in the vicinity of EMF- or electromagnetic interference (EMI)-sensitive land uses. Any EMI or EMF effects during testing would be similar to those described in Chapter 4, Section 4.6, *Electromagnetic Fields and Electromagnetic*

*Interference.* There would be *no effect* on human health from the use of EMF equipment during construction, and no mitigation is required.

## 5.5.8 Energy

BART Extension construction would consume gasoline and diesel through operation of heavy-duty construction equipment and vehicles. Twin-Bore and Single-Bore Option have been proposed for the tunnels. Energy usage during construction of either option, while short-term, would encompass a period of approximately 8 years. Based on the greenhouse gas (GHG) assessment (see Chapter 4, Section 4.9, *Greenhouse Gas Emissions*), energy use associated with BART Extension construction was calculated and estimated to result in the one-time consumption of 625,667 and 632,929 million British thermal units (BTU) (direct energy) for the Twin-Bore and Single-Bore Options, respectively.<sup>1</sup>

VTA's adopted Sustainability Program requires projects to "incorporate sustainability and green building principles and practices in the planning, design, construction, and operation of new VTA facilities." The BART Extension would, to the extent feasible, use recycled and regionally or locally available materials, as well as reuse soils onsite or elsewhere in the vicinity. These strategies would reduce hauling requirements and associated on-road fuel consumption, and ensure the BART Extension would not result in substantial waste or inefficient use of energy. Therefore, there would be *no adverse effect* related to energy.

## 5.5.9 Geology, Soils, and Seismicity

### 5.5.9.1 Liquefaction

All of the stations and the Newhall Maintenance Facility would be located in areas with moderate liquefaction potential. Approximately 100 and 700 feet northeast of the existing Diridon Station the alignment crosses the two (approximately 100-foot-wide) stream channels (Los Gatos Creek and Guadalupe River, respectively), where the liquefaction potential is characterized as being very high. The approximately 500-foot-long segment of the alignment near the existing Diridon Station between the two stream channels is rated as having moderate liquefaction potential. Liquefaction potential is moderate to high and may damage project facilities along the alignment and in station areas.

The BART Extension would be designed and constructed to meet or exceed standards set forth by the California Building Code and the pertinent BART Facilities Standards. It would also be designed and constructed using the site-specific measures provided in Mitigation Measure GEO-CNST-A. Because the BART Extension would comply with the California Building Code and the pertinent BART Facilities Standards requirements and VTA would

---

<sup>1</sup> Construction BTU calculated based on a conversion of kilograms of carbon dioxide (CO<sub>2</sub>) per gallon of fuel consumed equaling 10.20648 kilograms (kg) CO<sub>2</sub> per gallon for diesel and 8.7775 kg CO<sub>2</sub> per gallon for gasoline from the Climate Registry (2015), with a direct BTUs per gallon rate of 127,464 for diesel and 116,090 for gasoline.

implement Mitigation Measure GEO-CNST-A, there would be *no adverse effect* in terms of liquefaction.

### **Mitigation Measure GEO-CNST-A: Incorporate Design Specifications to Minimize Effects from Liquefaction Hazards**

If BART Extension stations, system facilities, or portions of the alignment are determined to be in areas exceeding pertinent codes and standards including the California Building Code and BART Facilities Standards Design Criteria for liquefaction, the following methods will be implemented by VTA during construction to minimize the potential impacts. The exact methods to reduce impacts from liquefaction will be determined during final engineering.

- Pile foundations will be used as a means of ground densification as a cost-effective mitigation measure for the seismic liquefaction hazard.
- The parking garages at the stations will be supported on piles.
- For shallow foundations for other peripheral facilities around the stations and pavement and parking lot, the following will be implemented if necessary.
  - Use additional reinforcement, construction joints, and grade beams.
  - Integrate subgrade improvements (using geotextile fabric and structural fill), and other methods to accommodate potential ground settlements.
- To mitigate potential liquefaction-related uplift of the BART Extension's underground tunnels and stations situated below the water table in liquefiable soils, VTA will ensure that the construction contractor either applies anchors or designs the structures' concrete foundations and walls thick enough to make the total weight of the structures large enough to completely counteract the liquefaction-related uplift force.
- Other liquefaction hazard mitigation measures used in previous BART projects that may be considered for the BART Extension are as follows.
  - In-situ treatment/densification with vibro-replacement stone columns
  - Load transfer to underlying bearing layers, which are non-liquefiable with soil/cement columns
  - Over-excavation and replacement of liquefaction prone soils with compacted engineered fill

#### **5.5.9.2 Surface Settlement**

According to the *BART Silicon Valley Phase II Santa Clara Extension Project Geotechnical Memorandum* prepared by PARIKH Consultants, Inc. in February of 2014 and the *SVSX Single Bore Feasibility Study* prepared by EPC Consultants, Inc. in January 2016, construction of the BART Extension Alternative has the potential to cause surface

settlements and lateral ground movements during construction of the tunnel and cut-and-cover stations. The purpose of these analyses was to assess the magnitude and likelihood of settlement and ground movement, physical damage to structures or utilities caused by potential settlement or ground movement, and significant impacts related to any physical damage on performance of structures or utilities that may be caused by tunnel boring and cut-and-cover construction. The analyses also recommended appropriate mitigation measures.

Along the tunnel alignment, the maximum surface settlement induced during tunnel boring is predicted to be in a range categorized as between negligible and slight. Minor cracking that can easily be patched, and sticking windows or doors would characterize slight damage. Any settlement would be distributed in a “trough” running parallel to and centered over the twin tunnel bores, with the maximum settlement occurring at the centerline of the trough between the two bores and approximately 0.50 inch. The maximum settlement with the Single-Bore Option is 1 inch (EPC Consultants, Inc. 2016).

For cut-and-cover construction, surface settlement varies with distance from the excavation, with a maximum being at the face of the excavation wall to zero at the “limit of influence,” a horizontal distance around the excavation equal to twice the depth of excavation. The maximum surface settlement adjacent to the open cut excavations during construction is predicted to be approximately 1.4 inches. However, the potential for ground settlement during construction is greatly reduced through the use of soil-cement mix or slurry diaphragm walls.

The surface settlements and ground movements have the potential to damage structures, which could be a potentially adverse effect. However, the BART Extension would provide ground treatment measures, strengthening of structures, and underpinning of structures on a case-by-case basis prior to tunnel boring or cut-and-cover construction. The tunnel bores would be constructed using pressurized closed-faced TBMs (Figure 5-13). The purpose of a closed-face machine is to balance the surrounding ground pressure by creating a pressure within the excavation chamber at the front of the TBM (Figure 5-14). Closed-face TBMs keep out groundwater, stabilize the tunnel face, and minimize settlement and lateral ground movements. Furthermore, while underground, the TBM’s excavation chamber is filled with soils excavated from the tunnel face. Conditioning agents are added to the soil in the chamber to aid in maintaining the correct face pressure. By maintaining the chamber pressure close to in-situ (pre-tunneling) water and earth pressure in the ground, the likelihood of groundwater inflows and excessive ground losses are substantially reduced, thereby minimizing ground settlement at the surface. In addition to these design requirements, Mitigation Measures GEO-CNST-B through GEO-CNST-F would be implemented to reduce the magnitude and likelihood of surface settlements and ground movements, physical damage, or functional effects. There would be *no adverse effect* after mitigation.

With implementation of design requirements and mitigation measures, the likelihood of damage due to surface settlements and ground movements would be low. However,



additional studies of potential settlements and ground movements would be conducted during subsequent engineering phases.

#### **Mitigation Measure GEO-CNST-B: Implement Preconstruction Condition Surveys along the Tunnel Alignment**

Preconstruction condition surveys of the interiors and exteriors of select structures within the settlement trough along the tunnel alignment and within the limit of influence around the cut-and-cover excavations will be conducted by independent surveyors to assess the condition of each property. These surveys will include written and photographic (video and still) records. The results of these surveys will be compared with post-construction condition surveys so that any effects of tunneling and cut-and-cover construction on structures can be assessed. For the tunnel activity, surveys will be performed as close to the planned dates of tunneling as possible so that the results are as current as possible. Therefore, surveys will be performed prior to passage of the tunnel boring machines, with some surveys conducted once tunneling has commenced.

#### **Mitigation Measure GEO-CNST-C: Monitor Ground Surface during Tunneling Activities**

For the tunneling activity, ground surface monitoring will be performed prior to and during construction. Instrumentation will be installed to monitor ground movements and effects of tunnel boring on structures and utilities. Monitoring can be used to direct real-time modifications, as appropriate, to tunneling practices and procedures to assist in minimizing adverse effects along the tunnel alignment.

#### **Mitigation Measure GEO-CNST-D: Monitor Settlement Effects around Cut-and-Cover Excavations**

Monitoring points will be mounted on select structures within the settlement trough along the tunnel alignment and within the limit of influence around the cut-and-cover excavations to monitor any effects of settlement.

#### **Mitigation Measure GEO-CNST-E: Implement Preconstruction Condition Surveys for Utilities**

Preconstruction condition surveys will be conducted of utilities deemed to be potentially at risk due to surface settlement or ground movement at BART Extension and TOJD sites. Major utilities deemed to be at risk will be monitored during construction. Coordination with utility providers will be conducted prior to installation of utility monitoring points.

#### **Mitigation Measure GEO-CNST-F: Minimize Excavation Bottom Failure Impacts**

If excavation bottom fails due to bottom heave, piping, or blow-out, the following measures will be implemented.

- Remove water found in the pervious sand layer via dewatering.
- Install deep sheeting. The sheet pile may also function as a cut-off to prevent sand boiling at the bottom of excavation due to excessive hydrostatic pressure within the loose soils.
- Based on the boring data, encountering of the loose soils at the foundation subgrade may be anticipated at isolated locations for excavation of the stations. Deeper shoring may be required to penetrate through the aquifer to prevent the occurrence of the sand boiling condition. Deep soil mixing may have to be considered under this condition if drivability of the shoring sheet pile through the dense to very dense sand at depths is a geotechnical concern due to the vibration and/or noise impact on the surrounding environment.

### 5.5.9.3 Excavation Bottom Stability or Disturbance

Soft to medium stiff clay and loose to medium dense sand may be encountered at the bottom of excavations for stations and other development. Where these soil conditions occur, excavation bottom instability may result from bottom heave, piping, or blow-out. Bottom heave is typical for excavations in soft clays. Piping may be a concern if the force of the upward flow of water exceeds the buoyant weight of the soil at the excavation bottom. Blow-out is another mode of failure in which a pervious sand layer is located below the clay layer at excavation bottom and is not drained in advance. Blow-out occurs when hydrostatic pressures at the base of the clay layer exceed the shear strength and weight of the clay plug.

If excavation bottom fails due to bottom heave, piping or blow-out, Mitigation Measure GEO-CNST-F would be implemented to reduce impacts so there would be *no adverse effect*.

Soft and loose saturated native soil deposits could be encountered at the excavation bottom. If clay and saturated sand deposits are sufficiently disturbed during construction activities at the bottom of an excavation, the deposits could become soft and loose. Consequently, working conditions at the bottom of the excavation may become difficult and cause the loss of equipment mobility. Adequate measures should be taken to minimize the disturbance of the sensitive deposits at the excavation subgrade. The disturbance of sensitive deposits or the existence of soft or loose ground conditions may be minimized by constructing a working platform as described in Mitigation Measure GEO-CNST-G. With implementation of this mitigation measure, there would be *no adverse effect*.

#### **Mitigation Measure GEO-CNST-G: Minimize Disturbance of Sensitive Deposits at the Excavation Subgrade**

In areas where clay and saturated sand deposits are sufficiently disturbed during construction activities at the bottom of an excavation and soft and loose saturated soil deposits are encountered, VTA will ensure that the contractor constructs a working platform as described below.

- Over-excavate 18 inches below the native subgrade.
- Place a stabilizing geotextile fabric or a geogrid at the bottom of the over-excavation.
- Backfill the over-excavation with Class 2 Aggregate Base, Structural Backfill, or other bridging material.
- Overlap the ends of the geotextile fabric on top of the bridging material for a minimum distance of 2 feet.

#### 5.5.9.4 Expansive Soils

Expansive soils are a concern for the proposed structures for system facilities, parking, and vehicular and pedestrian access at the stations and other sites. Some of the soils at station locations and the Newhall Maintenance Facility have high plasticity indices of between 21 and 40, meaning that the soils have moderate to high expansion potential.

The BART Extension would be designed and constructed to meet or exceed standards set forth by the California Building Code and the pertinent BART Facilities Standards and using site-specific mitigation measures described in Mitigation Measure GEO-CNST-H. Because the BART Extension would comply with the California Building Code and pertinent BART Facilities Standards requirements, and because VTA would implement Mitigation Measure GEO-CNST-H, there would be *no adverse effect* related to expansive soils.

##### **Mitigation Measure GEO-CNST-H: Incorporate Design Specifications to Minimize Effects from Expansive Soils**

VTA will ensure that the following specifications are incorporated into the BART Extension's final design when encountering expansive soils.

- Deepen foundations to below the zone of moisture fluctuation.
- Use mat foundations that are designed to resist the deflections associated with expansive soil.
- Perimeter footings will have a minimum depth of 24 inches below the lowest adjacent grade to reduce the impact from the uplift pressure in expansive soils.
- Any expansive soil in the upper 18 inches of building pads will be lime treated or replaced with low to non-expansive soil with a Plasticity Index of 12 or less.
- Use moisture barriers to minimize the variation of change in the moisture content within the expansive soil.

#### 5.5.9.5 Paleontological Resources

The BART Extension would be constructed in areas of San Jose and Santa Clara that have been previously developed. Consequently, any paleontological resource or site or unique geologic feature in these areas would likely have been discovered during previous development. However, because of cut-and-cover excavation depths involved in construction

of the BART Extension, there is a potential for discovery of previously unknown resources. In the event that construction activities encounter a unique paleontological resource or unique geologic feature, implementation of Mitigation Measure GEO-CNST-I would reduce potential impacts to a *no adverse effect* level.

#### **Mitigation Measure GEO-CNST-I: Stop Construction if Paleontological Resources are Discovered and Determine Appropriate Action**

If suspected paleontological resources are encountered during grading and site preparation activities, all work in the immediate vicinity of the find shall halt until a qualified paleontologist can evaluate the find and make recommendations. Paleontological resource materials may include resources such as fossils, plant impressions, or animal tracks preserved in rock. If the qualified paleontologist determines that the discovery represents a potentially significant paleontological resource, additional investigations and fossil recovery may be required to mitigate adverse impacts from implementation of the BART Extension. Construction shall not resume until the resource-appropriate measures are recommended or the materials are determined to be not significant.

### **5.5.10 Greenhouse Gas Emissions**

Construction of the BART Extension would generate direct emissions of carbon dioxide (CO<sub>2</sub>), methane (CH<sub>4</sub>), and nitrous oxide (N<sub>2</sub>O) from mobile and stationary construction equipment exhaust, as well as employee and haul truck vehicle exhaust. Indirect emissions would be generated from water use for fugitive dust control. It is estimated that the total GHG emissions associated with construction of the BART Extension would be 50,200 and 50,787 metric tons of carbon dioxide equivalent (CO<sub>2</sub>e) for the Twin-Bore and Single-Bore Options, respectively. Because the construction activity would last approximately 8 years, the average annual CO<sub>2</sub>e emissions associated with Twin-Bore and Single-Bore Options would be 6,275 and 6,348 tons of CO<sub>2</sub>e per year, respectively. Given that this a transit project that would, in the long-term, improve regional air quality, construction greenhouse gas emissions are considered to have *no adverse effect*.

### **5.5.11 Hazards and Hazardous Materials**

The primary issues related to hazardous materials during construction are the health and safety of construction workers, the public, and the environment, and the proper management of hazardous materials. Adverse effects from hazardous materials during construction of each alternative can be divided into effects caused by existing soil contamination, existing groundwater contamination, structure demolition, and potential surface water contamination.

Based on the October 2015 *VTA's BART Silicon Valley Phase II Extension Project Initial Site Assessment* (ISA) (BASELINE Environmental Consulting 2016), hazardous materials may be present in soil, ballast, and groundwater beneath the alignment. The ISA identified

437 sites with known releases of hazardous materials within a 1-mile radius of the BART Extension. A total of 43 of the 437 hazardous materials release sites are under active regulatory oversight and/or have land use restrictions and are located on, adjacent to, or hydraulically upgradient of the alignment. Petroleum hydrocarbons, chlorinated solvents, and metals are the primary contaminants of concern in soil and groundwater from the 43 known hazardous materials release sites. Arsenic and lead are the primary contaminants of concern in shallow soil and ballast along existing railroad corridors. The disturbance of contaminated materials during construction activities, such as excavation and dewatering, could pose a potential threat to human health and the environment. In 2008, the Regional Water Quality Control Board (Regional Water Board) approved a Containment Management Plan (CMP) for Phase I and Phase II Projects.

Implementation of the CMP and Mitigation Measure HAZ-CNST-A would ensure that site-specific remedial action plans (RAPs) are prepared and implemented to reduce impacts on human health and the environment that could result from the disturbance of hazardous materials in soil and ballast materials during construction of the BART Extension. With these measures, impacts would result in *no adverse effect*.

#### **Mitigation Measure HAZ-CNST-A: Prepare Remedial Action Plans**

Prior to construction, new and/or amended RAPs will be prepared for the BART Extension and approved by the Regional Water Quality Control Board. The RAPs will satisfy the key objectives of the CMP (e.g., characterization of soil and ballast quality relative to the maximum acceptable contaminant levels for reuse) and incorporate measures for managing soil, ballast, and groundwater from the CMP (e.g., sampling and analysis, health and safety, stockpiling, offsite disposal, and treatment) to address all known and potential sources of environmental contamination identified in the ISA. Measures to satisfy Regulatory notification requirements and approval measures (e.g., additional sampling and analysis), if necessary, for soil excavation and/or dewatering associated with land-use covenants near the Diridon and Santa Clara Stations and over the tunnel alignments between these stations will be provided. The RAPs will also include an assessment of potential vapor intrusion concerns for indoor residents and workers from groundwater contaminant plumes, such as chlorinated solvents. In coordination with the Regional Water Quality Control Board, selected remedial measures to protect human health may include, but are not limited to, source removal of contaminated materials, in-situ treatment, and implementation of engineering controls (e.g., vapor barriers) and/or institutional controls prior to building occupancy.

### **5.5.11.1 Contaminant Management Plan**

In 2008, the Regional Water Board approved a CMP for Phase I and Phase II Projects that provides a framework for proper characterization and management of contaminated soil, groundwater, railroad ballast, and buildings materials that could be encountered during all construction activities (AECOM Inc. 2008). The approach for assessing and managing



hazardous materials in soil and ballast materials that would be encountered during earthwork activities is described in the CMP. The CMP would be implemented through site-specific RAPs prepared for the entire BART Extension and approved by the Regional Water Board. Under the oversight of the Regional Water Board, compliance with the CMP and RAPs is mandatory.

The CMP describes how to meet the following key objectives.

- Identify various scenarios under which large volumes of soil and railroad ballast generated during construction can be safely reused.
- Identify maximum acceptable contaminant levels for each reuse scenario, by combining existing regulatory agency guidance with calculation of risk-based cleanup goals.
- Identify sampling and analysis, stockpiling, transportation, health and safety, and other procedures by which soil and ballast must be managed in order to meet safety, regulatory and other standards.
- Define how the groundwater that would be encountered during construction will be characterized, properly treated and discharged.
- Define how building materials, if encountered during construction, will be characterized, handled and disposed.

The CMP is incorporated into this SEIS/SEIR by reference. While this section includes information from the CMP, the reader should refer to the CMP for the complete analysis of adverse effects and the mitigation measures to be implemented during construction.

**Soil and Ballast.** The approach for assessing and managing hazardous materials in soil and ballast materials that would be encountered during earthwork activities is described in the CMP. The CMP would be implemented through site-specific RAPs prepared for the entire alignment and approved by the Regional Water Board. Under the oversight of the Regional Water Board, compliance with the CMP and RAPs is mandatory.

Implementation of Mitigation Measure HAZ-CNST-A would ensure that site-specific RAPs are prepared and implemented to reduce impacts on human health and the environment that could result from the disturbance of hazardous materials in soil and ballast materials during construction to *no adverse effect*.

**Groundwater.** Dewatering of the shallow groundwater zone would be required during certain excavation activities. As described in the CMP, all extracted groundwater would be considered potentially contaminated and would require characterization to determine the appropriate treatment requirements (if necessary) for discharge/disposal. The extracted groundwater would be collected and managed for disposal/treatment in compliance with local and/or state regulations. Groundwater handling may include any of the following.

- Discharge to the local sanitary sewer system.
- Discharge to the storm drain system.

- Containment and disposal at an appropriately permitted offsite facility.

As described in the CMP, aboveground treatment of the extracted groundwater, such as by gravity sedimentation followed with activated carbon adsorption using granular activated carbon vessels, would be performed prior to discharge. Removal of metals may be required based on permit conditions, dewatering rates, and concentrations of metals encountered during the dewatering. Discharge of treated dewatering groundwater to the local sanitary sewer system is regulated by the San Jose/Santa Clara Water Pollution Control Plant for the Cities of San Jose and Santa Clara. Discharge of treated dewatering groundwater to the storm drain system is regulated by the Regional Water Board, under a National Pollutant Discharge Elimination System (NPDES) general permit. As compliance with the CMP and existing regulations is mandatory, construction of the BART Extension would result in *no adverse effect* on human health and the environment related to hazardous materials in extracted groundwater.

**Building Demolition.** Construction activities for the BART Extension would include demolition of buildings on construction staging areas throughout the alignment that may contain hazardous materials, such as asbestos containing materials (ACM) and lead-based paint (LBP). Improper removal and/or disposal of hazardous building materials during demolition activities could potentially result in an accidental release of hazardous materials into the environment. The removal of hazardous building materials prior to demolition is governed by federal and state regulations. Section 19827.5 of the California Health and Safety Code requires that local agencies not issue demolition or alteration permits until an applicant has demonstrated compliance with notification requirements under applicable federal regulations regarding hazardous air pollutants.

Friable ACM is considered a regulated material subject to the U.S. Environmental Protection Agency's (EPA's) Asbestos National Emission Standard for Hazardous Air Pollutants requirements (Code of Federal Regulations, Title 40, Part 61, Subpart M) and the BAAQMD's demolition requirements (Regulation 11-2). The EPA and BAAQMD's asbestos regulations include requirements for agency notifications, engineering controls, waste handling, worker certifications, and reporting. All friable ACM materials must be disposed of at a landfill certified to accept friable ACM.

Loose and peeling LBP may be present and must be disposed of as a state and/or federal hazardous waste if the concentration of lead equals or exceeds applicable waste thresholds. State and federal Occupational Safety and Health Administration (OSHA) regulations require a supervisor who is certified to identify existing and predictable lead hazards to oversee air monitoring and other protective measures during demolition activities where lead-based paint may be present. Special protective measures and notification of Cal/OSHA are required for highly hazardous construction tasks related to lead, such as manual demolition, abrasive blasting, welding, cutting, or torch burning of structures where LBP is present.

Fluorescent lighting tubes and ballasts, mercury thermometers, and several other common items containing hazardous materials are regulated under the California Universal Waste

Rule, which is less stringent than most other federal and state hazardous waste regulations. To manage universal waste in accordance with the streamlined state requirements, generators must relinquish the waste to a universal waste transporter, another universal waste handler, or a universal waste destination facility.

Prior to demolition, the CMP requires that a hazardous materials building survey be conducted by the demolition contractor to identify the presence of hazardous and contaminated materials to be disturbed and/or removed during demolition activities. If hazardous building materials (including remaining chemicals that will be removed during demolition) are identified during the hazardous building materials survey, the CMP requires the preparation of a site-specific Hazardous Materials Management Plan that describes how the materials will be handled according to the applicable laws and regulations. As required by the Regional Water Board, the CMP requirements for building demolition on the BART Extension sites will be further described by site-specific RAPs (Mitigation Measure HAZ-CNST-A). As compliance with the CMP, RAPs (Mitigation Measure HAZ-CNST-A), and existing regulations is mandatory, construction of the BART Extension would result in *no adverse effect* on human health or the environment related to hazardous building materials.

## 5.5.12 Land Use

Existing buildings and structures on parcels identified for construction staging will need to be demolished prior to start of construction. Therefore, the CSAs would result in the acquisition, and displacement, of several businesses located within the study area. Community displacement is discussed in Chapter 4, Section 4.14, *Socioeconomics*. Additionally, refer to Sections 5.5.2 and 5.5.13, respectively, for discussions on adverse construction effects that may cause transportation- and noise-related disruptions to local businesses.

## 5.5.13 Noise and Vibration

Construction of the BART Extension has the potential to generate high levels of noise and vibration that may adversely affect nearby residential, commercial, and institutional land uses. In addition, some construction activities may generate vibration levels that could damage nearby structures. In order to determine the potential noise and vibration effects during construction, an analysis of construction period effects from noise and vibration was performed. Construction noise and vibration projections are based on typical construction equipment that contractors may use at the site. The analysis included below is supported by the *Noise and Vibration Technical Report* prepared by Wilson Ihrig in October 2016.

### 5.5.13.1 Noise Impacts

Criteria provided by FTA to assess noise impacts during construction are summarized in Table 5-4. The criteria are based on land use and time of day and are given in terms of day-night equivalent ( $L_{eq}$ ) for an 8-hour work shift.  $L_{eq}$  represents the level of a steady noise

level containing the same total noise energy as the fluctuating noise over a given time period. For this analysis, the residential daytime noise guidelines are also applied to schools.

**Table 5-4: FTA Construction Noise Criteria**

Land Use	Noise Limit: 8-Hour L <sub>eq</sub> (dBA) Daytime	Noise Limit: 8-Hour L <sub>eq</sub> (dBA) Nighttime	30-day Average L <sub>dn</sub> (dBA)
Residential	80	70	75 <sup>a</sup>
Commercial	85	85	80 <sup>b</sup>
Industrial	90	90	85 <sup>b</sup>

Source: FTA 2006.

<sup>a</sup> In urban areas with very high ambient noise (L<sub>dn</sub> > 65 dB), day-night level (L<sub>dn</sub>) from equipment should not exceed existing ambient by more than 10 decibels (dB).

<sup>b</sup> Use a 24-hour L<sub>eq</sub>, not L<sub>dn</sub>.

Although no identified limits on maximum construction equipment noise levels are in force in any of the local jurisdictions along the alignment, construction activities will generally adhere to City construction timeframes, as presented in Table 5-5. However, certain construction activities, such as emergency work (e.g., water main break), utilities work, critical structures, or works performed at night to minimize traffic delays require extended work hours and may be exempted from these constraints by VTA after coordinating with the Cities.

**Table 5-5: Construction Hours by Jurisdiction**

Location	Allowable Construction Timeframes
City of San Jose	7:00 a.m. to 7:00 p.m. – weekdays
City of Santa Clara	7:00 a.m. to 6:00 p.m. – weekdays 9:00 a.m. to 6:00 p.m. – Saturday

Source: *BART Extension to Milpitas, San Jose, and Santa Clara Draft Supplemental Environmental Impact Report 2007*.

Note: Any construction activities outside the allowable hours would need to obtain noise variances from the local cities per San Jose Ordinance 26248, 26594 and Santa Clara Ordinance 1549 § 1, 7-15-86; Ord. 1556 § 1, 9-16-86. Formerly § 18-32.3

The following analysis draws upon the construction noise and vibration analysis performed in 2005 (HMM/Bechtel SVRT 2005) and supplemented in 2016 (WIA 2016).

## Portals

The 2005 construction noise study (HMM/Bechtel SVRT 2005) concluded that construction at the east and west portal sites would not cause noise impacts. This noise analysis was reviewed and remains valid as there has not been a substantial change in construction methodology and proximity of sensitive receptors. The construction activities at the portals would be extensive and involve pre-construction, construction and testing and

commissioning. These activities would last for approximately eight years as shown in Figure 5-1.

### **East Portal**

The land use around the East Portal is primarily industrial. The closest building is 340 feet away on Las Plumas Avenue. The projected 8-hour  $L_{eq}$  is 71 dBA, which is less than the daytime criterion of 90 dBA (see Table 6.12-1 in Chapter 6, Section 6.12, *Noise and Vibration*). The East Portal construction would have *no impact* on noise.

### **West Portal**

There are four single-family homes (single-story) on Stockton Avenue approximately 500 feet from the site of the West Portal. The projected 8-hour  $L_{eq}$  is 70 dBA. The daytime  $L_{eq}$  criterion is 80 dBA and 70 dBA for nighttime (see Table 6.12-1). The 8-hour  $L_{eq}$  is below the daytime criterion, and at the nighttime criterion. Therefore, the projected noise level would not exceed the construction noise criteria. The West Portal construction would have *no impact* on noise.

### **Alum Rock/28<sup>th</sup> Street Station**

The adjacent land use is primarily light industrial on both sides of North 28<sup>th</sup> Street. The closest sensitive receiver is the Five Wounds Portuguese National Church, which would be at least 350 feet from the station box construction. However, the church school is much closer and would require construction noise mitigation (noise wall or noise curtain to achieve the FTA criteria). A noise wall or noise curtain would be constructed high enough at a minimum to block line-of-sight to equipment generating noise, in which case typical 5 dBA of noise reduction might be expected. The closest residences are on 27<sup>th</sup> Street. Four single-family residences would be between 400 and 750 feet away. At these distances the 8-hour  $L_{eq}$  is projected to be from 63 to 72 dBA. This would exceed the nighttime criterion for residences, but not the daytime criterion (see Table 6.12-1).

The construction duration for this and other stations is estimated at 5–6 years as shown in Figure 5-1. An adverse noise effect would occur if there were nighttime work. Implementation of Mitigation Measures NV-CNST-A through NV-CNST-O (see Section 5.5.13.3) would reduce this to *no adverse effect*.

The Single-Bore Option would not involve cut-and-cover aboveground station construction except at entrances and system facilities, and, therefore, construction noise would be substantially less than for the Twin-Bore Option. The Single-Bore Option would similarly have *no adverse effect*.



## Ventilation Shaft/Substation/Gap Breaker/Pump Station Facilities

### 13<sup>th</sup> Street Ventilation Structure

There are residences 85 feet and at 95 feet away from the 13<sup>th</sup> Street ventilation facility. Consequently, construction of the 13<sup>th</sup> Street ventilation facility is predicted to result in adverse construction noise effects. Implementation of Mitigation Measures NV-CNST-A through NV-CNST-O (see Section 5.5.13.3) would reduce this to *no adverse effects*. This conclusion applies to both the Twin-Bore and Single-Bore Options.

### Stockton Avenue Ventilation Structure

There is one residence approximately 120 feet from the proposed Stockton Avenue Ventilation Structure FSS. Construction of either of the two southernmost alternative sites would result in adverse construction noise effects. Implementation of Mitigation Measures NV-CNST-A through NV-CNST-O (see Section 5.5.13.3) would reduce this to *no adverse effect*. This conclusion applies to both the Twin-Bore and Single-Bore Options.

## Downtown San Jose Station

### Downtown San Jose Station East Option

This option is two blocks to the east of the West Option. The City office building is between 4<sup>th</sup> and 6<sup>th</sup> Streets and at its closest is 100 to 150 feet away. The projected noise level is an 8-hour  $L_{eq}$  of 79 dBA, which is less than the 85 dBA criterion for commercial spaces, which could include offices. The other buildings between 4<sup>th</sup> and 3<sup>rd</sup> Streets are similar to those for the Downtown San Jose West Option, which include residences aboveground floor and commercial spaces. A significant noise effect on some of the residences could occur for the Downtown San Jose East option. Implementation of Mitigation Measures NV-CNST-D through NV-CNST-O (see Section 5.5.13.3) would reduce noise impacts, but not guarantee that the noise levels would be less than the FTA criteria. Therefore, construction noise impacts for the Downtown San Jose Station East Option would be an *adverse effect*.

The Single-Bore Option would not involve cut-and-cover aboveground station and crossover construction except at entrances and system facilities, and, therefore, construction noise would be less than for the Twin-Bore Option. However, the Single-Bore Option would generate substantial noise impacts at the Downtown San Jose Station East Option and therefore similarly result in an *adverse effect*.

### Downtown San Jose Station West Option

There are several apartments on both sides of Santa Clara Street on the upper floors of buildings between 3<sup>rd</sup> and 4<sup>th</sup> Streets. The Town Park Towers, a 10-story apartment building, is on 3<sup>rd</sup> Street about 200 feet from Santa Clara Street. While the lower floors on the west side are somewhat shielded by adjacent buildings, on the east side all units have a clear line of sight to Santa Clara Street. All other buildings along Santa Clara Street are commercial at ground floor with offices above.

The buildings on Santa Clara Street are approximately 40 feet from the centerline of the closest construction activity. For commercial buildings in the area, tunnel, trackwork, and ventilation structures, and, systems installation construction would be in compliance with FTA's 8-hour  $L_{eq}$  noise limit of 85 dBA with possibly occasional exceedances of 1 to 2 dBA. For the residences in the area, nighttime construction could exceed the 8-hour  $L_{eq}$  limit of 70 dBA by as much as 15 to 18 dBA, making nighttime construction difficult to mitigate. During the daytime, the FTA limit is 80 dBA, which is projected to be exceeded by 5 to 8 dBA. It is projected that some of the units at the Town Park Towers could be exposed to an 8-hour  $L_{eq}$  of 76 dBA, which exceeds the nighttime limit but not the daytime limit.

An adverse noise effect on some of the residences could occur for the Downtown San Jose Station West Option. Implementation of Mitigation Measures NV-CNST-A through NV-CNST-O (see Section 5.5.13.3) would reduce noise impacts, but not guarantee that the noise levels would be less than the FTA criteria. Therefore, construction noise impacts for the Downtown San Jose Station West Option would be an *adverse effect*.

The Single-Bore Option would not involve cut-and-cover aboveground station and crossover construction except at entrances and system facilities, and, therefore, construction noise would be less than for the Twin-Bore Option. However, the Single-Bore Option would generate noise impacts at the Downtown San Jose Station West Option and therefore similarly result in an adverse effect.

### **Diridon Station (South and North Options)**

There are residences located close to the Diridon Station (South and North Options) to the south and west. Consequently, construction of the Diridon Station has the potential to result in adverse construction noise effects. Implementation of Mitigation Measures NV-CNST-A through NV-CNST-O (see Section 5.5.13.3) would reduce noise impacts, but not guarantee that the noise levels would be less than the FTA criteria. Therefore, construction noise impacts for the Diridon Station (South and North Options) would be an adverse effect.

### **Newhall Maintenance Facility**

Across the existing railroad tracks, there are single-family and multi-story residences to the southwest and west of the alignment leading to the Newhall Maintenance Facility. Construction of the maintenance facility has the potential to result in adverse construction noise effects; however, over 100 trains a day use the existing railroad tracks generating a substantial noise impact. Implementation of Mitigation Measures NV-CNST-A through NV-CNST-O (see Section 5.5.13.3) would reduce construction noise at this location to *no adverse effect*. This conclusion applies to both the Twin-Bore and Single-Bore Options.

### **Santa Clara Station**

The nearest residences are located 396–614 feet from the station. For all three phases of construction the noise from construction at these two receptors is projected to be within the construction noise criteria. The highest level (72 dBA) is projected to occur in Phase II at the

hotel during the daytime. No noise impacts are projected to occur during construction of this station option. Implementation of Mitigation Measures NV-CNST-A through NV-CNST-O (see Section 5.5.13.3) would reduce construction noise at this location this to no adverse effect. This conclusion applies to both the Twin-Bore and Single-Bore Options.

### **Tunnel Construction: Muck Train**

Soils excavated by the TBM can be removed by a muck train or conveyor system. Muck trains have been found to cause groundborne noise impacts. The groundborne noise can generally be fully mitigated by implementation of a ballast mat underneath the tracks on which the muck train rides. With a ballast mat, the groundborne noise from muck trains should result in no adverse effect. If not, then a conveyor system could be used to eliminate groundborne noise from soil removal. Implementation of Mitigation Measures NV-CNST-P through NV-CNST-S (see Section 5.5.13.3) applies to both the Twin-Bore and Single-Bore Options and would reduce this to *no adverse effect*.

### **5.5.13.2 Vibration Impacts**

FTA construction vibration criteria are based on the FTA ground-borne vibration annoyance criteria. For this assessment, the *frequent event* criteria are used because of the extended duration of the expected construction activity. FTA has set a damage criterion of 0.2 inch/second for fragile buildings and 0.12 inch/second for extremely fragile historic buildings. At these levels (0.2 inch/second or 0.12 inch/second for fragile historic buildings), a building may suffer architectural cosmetic damage, characterized by fine plaster cracking and the reopening of old cracks (FTA 2006). None of the local jurisdictions have vibration criteria that are applicable.

Construction vibration projections were made based on the construction scenarios described above. Actual vibration effects would be dependent on the methods and procedures used by the selected contractor. In particular, the location of equipment inside a construction zone has a large effect on the vibration exposure to nearby sensitive receptors, such as commercial buildings and residences. This information is typically not available at this stage of a project.

Construction activities can result in varying degrees of ground vibration, depending on the equipment, construction operation being performed, and the location of equipment inside a construction zone. The major construction vibration effects for this type of project are generally from impact and vibratory pile driving, blasting, and possibly large tracked dozers and compactors. The use of blasting is not anticipated at this time for the BART Extension Alternative.

Construction vibration projections are based on assumptions on the type of construction equipment the contractor would use at the site. Information on construction vibration is based on the FTA Guidance Manual (FTA 2006) and that reported in the available literature. It is important to note that information on construction vibration is very limited, probably due to the fact that there are rarely any vibration-related complaints during typical construction

operations except during blasting and impact or vibratory pile driving. Table 5-6 shows screening distance of sensitive receptors from adverse vibration effects.

**Table 5-6: Vibration Effects on Sensitive Receptors**

Type of Construction Activity	Vibration Annoyance <sup>b</sup> Distance to Vibration Effect (feet) <sup>a</sup>	Vibration Damage <sup>c</sup> Distance to Vibration Effect (feet) <sup>a</sup>
At-Grade Guideway	225	15
Retained Cut Guideway	140	10
Tunnel Guideway	125	10
Cut-and-Cover Subway Guideway	281	20
Construction Staging Areas	120	10
Source: HMMH 2003.		
<sup>a</sup> Adverse vibration effect is based on FTA frequent event vibration guidelines.		
<sup>b</sup> An adverse effect from vibration annoyance occurs when vibration levels reach 72 vibration velocity level (VdB).		
<sup>c</sup> Vibration damage is assumed to occur when vibration levels reach 95 VdB.		

Large tracked dozers and compactors generate vibration levels that may be perceptible within 30 to 35 feet and possibly cause cosmetic building damage within about 10 feet of construction activities. An augering drill rig may generate vibration levels that are perceptible within about 20 feet, but would probably not cause any building damage.

If a vibratory pile driver (i.e., sonic pile driver) is used to drive steel sheet piles at the 11 street crossings during at-grade utilities modifications, it would be perceptible at some of the nearby locations and may exceed the FTA damage criterion of 0.2 inch/second PPV for fragile buildings.

If non-impact pile driving methods are used, the maximum distance to vibration effects would be 315 feet, and the distance to potential cosmetic damage to nearby buildings would be 25 feet. The potential for serious foundation or structural damage, even when impact pile driving is used, occurs only at distances of 20 feet or less from the activity. The TBM may generate perceptible vibration at buildings within 20 feet of the tunnel, but the TBM is not projected to produce vibration levels high enough to cause even cosmetic damage.

Except for TBM operation, most construction vibration would occur during daytime hours. Operation of the TBM would be during two 10-hour shifts with estimated progress at a rate of from 30 to 75 feet a day depending on soil conditions encountered.

**Tunnel Construction: TBM**

The depth of the tunnel centerline below the ground surfaces typically ranges from approximately 40 to 60 feet. The tunnel bores would be between 10 feet below ground surface at the tunnel portals to 75 feet below ground surface. Residences may be located 45 to 75 feet from the tunnel center line, as some residences would be directly over the

tunnels. For those residences, the distance from the tunnel center is 45 feet or more. At 45 feet the vibration level (measured as PPV) is projected to be less than 0.02 inch/second. In terms of human perception, this vibration could vary from 75 to 83 vibration velocity level (VdB) depending on soil conditions. Typically, residences are at least 75 feet away from a tunnel centerline, and vibration would be less than 75 VdB.

### **Impacts on Buildings (Cosmetic Building Damage)**

A PPV of 0.02 inch/second is substantially below the most conservative building damage criterion of 0.12 inch/second, which addresses the potential for cosmetic damage (e.g., plaster cracks) to buildings in a fragile condition (e.g., possible older historic buildings). Consequently, there would be *no adverse effects* on buildings due to TBM operation with the Twin-Bore and Single-Bore Options.

### **Impacts on Occupants (Annoyance)**

The FTA impact criterion for infrequent events is 80 VdB for residences, for occasional events is 75 VdB, and for frequent events is 72 VdB. Because the perceptible vibration would last no more than 4 days, and typically only 3 days, the occasional events criterion (75 VdB) would be applicable. This level of vibration may be perceptible to some people.

For residences that are at least 75 feet horizontally from a tunnel centerline, the vibration would be lower than the criterion (72 VdB) for frequent events. For residences less than 75 feet horizontally from a tunnel centerline, the vibration may be perceptible depending on the depth of the tunnel and the horizontal distance of the residence from the tunnel centerline.

It is projected that residences within a horizontal distance of 50 feet of the tunnel centerline may be affected by TBM vibration for a period of up to 4 days. It is projected that there are approximately three dozen residences that could be affected by TBM vibration for a period of up to 4 days. Areas with high concentrations of residences less than 50 feet of the tunnel centerline include the portion of the alignment south of Berryessa Station along U.S. 101, and west of the existing Diridon Station as the alignment curves north and runs along Stockton Avenue. This would be a temporary impact. Mitigation Measures NV-CNST-P through NV-CNST-S (see Section 5.5.13.3) applies to both the Twin-Bore and Single-Bore Options and would reduce this to *no adverse effect*.

### **Station Excavation**

Vibration from station and cross-over (Twin-Bore Option) would be generated from implementation of excavation shoring and tiebacks where necessary. Construction of the Downtown Station (both East and West Station Options for the Twin Bore Option; only West Station Option for the Single-Bore Option) would require demolition and removal of the existing roadway and, in some places, possibly the sidewalk. After the station box is completed, the roadway would be rebuilt.



Table 5-7 indicates the various demolition and construction activities and the equipment that would produce vibration. Also indicated are the distance beyond which the vibration should be less than 0.12 inch/second PPV. Where a range of distance is shown, the distance depends on the actual equipment used and/or the local soil conditions.

**Table 5-7: Demolition and Construction Vibration Activity**

Activity	Equipment	Distance (feet) <sup>a</sup>
Demolition	Hoe Ram	20
	Jackhammer	10–15
Excavation	Trencher	20
	Caisson Drilling	20
	Hydro Mill Slurry Wall	5–10
	Drilling for Tiebacks	6–8
Roadway Subgrade Compaction	Vibratory Roller	35–40
<sup>a</sup> Distance to reach 0.12 inch/second.		

The results in Table 5-7 indicate that structures close to cut-and-cover station excavation could be exposed to excessive vibration. The closest historical buildings that could be impacted for the Twin-Bore Option include the following.

- 1375–1401 Santa Clara Street (Alum Rock/28<sup>th</sup> Street Station)
- 142–150 Santa Clara Street (Downtown San Jose Station East)
- 138 Santa Clara Street (Downtown San Jose Station East)
- 124–126 Santa Clara Street (Downtown San Jose Station East)
- 114–118 Santa Clara Street (Downtown San Jose Station East)
- 100 Santa Clara Street (Downtown San Jose Station East)
- 19 East 2nd Street (Downtown San Jose Station West)
- 42–48 Santa Clara Street (Downtown San Jose Station West)
- 36–40 Santa Clara Street (Downtown San Jose Station West)
- 22 North 1<sup>st</sup> Street (Downtown San Jose Station West)
- 8–14 South 1<sup>st</sup> Street (Downtown San Jose Station West)
- 34 Santa Clara Street (Downtown San Jose Station West)
- 81 Santa Clara Street (Downtown San Jose Station West) (for both the Twin-Bore and Single-Bore Options)
- Cahill Station and Santa Clara/Alameda Underpass (Diridon Station South and North Options)

Table 4.5-1 in Chapter 4, Section 4.5, *Cultural Resources* provides a full list of historical buildings close to the alignment. This effect is therefore considered to be adverse. Implementation of Mitigation Measures NV-CNST-P through NV-CNST-S (see Section 5.5.13.3) would reduce this to *no adverse effect*.

The contractor will be required not to exceed 0.12 inch/second construction vibration measured at historic buildings.

### **5.5.13.3 Noise and Vibration Mitigation Measures**

Construction activities would be carried out in compliance with FTA noise and vibration criteria and guidelines and would adhere to applicable local regulations. In addition, noise and vibration limits would be developed during final design and included in the construction noise and vibration specifications for the BART Extension Alternative. Regular noise and vibration monitoring would be performed during construction to verify compliance with these limits. This approach provides for site-specific analysis and allows the contractor flexibility to meet the noise and vibration limits in the most efficient and cost-effective manner. Noise and vibration control mitigation measures that would be applied as needed to meet the noise and vibration criteria for both the Twin-Bore and Single-Bore Options include the following. However, even with these mitigation measures, construction noise impacts at the Downtown San Jose Station (East and West Options) and Diridon Station (South and North Options) would remain adverse.

#### **Mitigation Measure NV-CNST-A: Incorporate FTA Criteria Compliant Construction Noise and Vibration Specifications**

A comprehensive construction noise and vibration specification will be incorporated into all construction bid documents requiring compliance with FTA criteria. The existence and importance of noise and vibration control specifications will be emphasized at pre-bid and preconstruction conferences, if necessary.

#### **Mitigation Measure NV-CNST-B: Locate Equipment as Far as Feasible from Sensitive Sites**

Stationary equipment, such as generators and compressors, will be located as far as feasible from noise and vibration sensitive sites, and be acoustically treated. Grout batch plants, grout silos, mixers, pumps, diesel pumping equipment, and similar noise and vibration generating equipment will also be located as far as feasible from noise sensitive sites, and be acoustically treated if necessary.

#### **Mitigation Measure NV-CNST-C: Construct Temporary Noise Barriers**

Temporary noise barriers or noise control blankets will be constructed in areas between noisy activities and noise-sensitive receptors, where practical and effective. Temporary noise barriers can reduce construction noise by 5 to 15 dB, depending on the height of the

barrier and the placement of the barrier. To be most effective, the barrier will be placed as close as possible to the noise source or the sensitive receptor. Temporary barriers tend to be particularly effective because they can be easily moved as work progresses to optimize performance. If temporary noise barriers and site layout do not result in compliance with the noise limit, retrofitting existing windows and doors with new acoustically rated units may be considered for the residential structures.

### **Mitigation Measure NV-CNST-D: Operate Equipment to Minimize Annoying Noises**

Contractors will be required to implement the following measures:

- Use electric instead of diesel-powered equipment, hydraulic tools instead of pneumatic impact tools, and electric instead of air- or gasoline-driven saws, where feasible.
- Use an augering drill-rig for setting piles in lieu of impact pile drivers, where feasible.
- Operate equipment so as to minimize banging, clattering, buzzing, and other annoying types of noises, especially near residential areas during nighttime hours.
- Turn off idling equipment, whenever possible.
- Line haul truck beds with rubber or sand to reduce noise, if needed and requested by the Resident Engineer. Line or cover hoppers, conveyor transfer points, storage bins, and chutes with sound-deadening material.
- During nighttime and weekends, use strobe warning lights and/or back-up observers during any back-up operations, where permitted by the local jurisdiction.

### **Mitigation Measure NV-CNST-E. Route Construction Trucks along Truck Routes Least Disturbing to Residents**

Construction-related truck traffic will be routed along truck routes and roadways that would cause the least disturbance to residents. Loading and unloading zones will be laid out to minimize truck idling near sensitive receptors and to minimize truck reversing so back-up alarms are minimized near residences.

### **Mitigation Measure NV-CNST-F: Secure Steel and Concrete Plates over Excavated Holes and Trenches**

Steel and/or concrete plates over excavated holes and trenches will be secured to reduce rattling when vehicles pass over. If complaints are received, contractors will use thicker plates, stiffer beams beneath the plates, and/or rubber gaskets between the beams and plates to further reduce rattling noise.

**Mitigation Measure NV-CNST-G: Use Best Available Practices to Reduce Excess Noise and Vibration**

The contractor will be required to use the best available practices to reduce the potential for exceedances of noise and vibration criteria due to construction activities. This may require the use of equipment with special exhaust silencers, construction of temporary enclosures or noise barriers around activities, and tracks for the tracked vehicles to be in good condition.

**Mitigation Measure NV-CNST-H: Adhere to Local Jurisdiction Construction Time Periods, to the Extent Feasible**

Local jurisdiction construction time periods will be adhered to, to the extent feasible, recognizing that nighttime and weekend construction may be necessary and/or preferred by VTA and local jurisdictions to reduce other related environmental effects such as traffic. VTA will coordinate with the cities of San Jose and Santa Clara on construction operations during nighttime and weekends, and where feasible adhere to local ordinances. San Jose Ordinance 26248, 26594 restricts construction to between 7 a.m. and 7 p.m. Santa Clara Ordinance 1549 § 1, 7-15-86; Ord. 1556 § 1, 9-16-86. Formerly § 18-32.3 restricts construction to between 7 a.m. and 6 p.m. on weekdays, and between 9 a.m. and 6 p.m. on Saturday.

**Mitigation Measure NV-CNST-I: Perform Preconstruction Ambient Noise Measurements at East and West Portal CSAs**

Require the contractor to perform preconstruction ambient noise measurements at the East and West Portal construction staging areas, at the station and ventilation shaft areas, and at the gap breaker areas. This will serve to document the noise environment just prior to start of construction at representative locations along the alignment. These measurements will be performed continuously over a minimum of 10 days (240 hours) at the staging areas, and at the station and ventilation shaft areas. At the gap breaker sites, 4 days (96 hours) of continuous noise measurements will be taken.

**Mitigation Measure NV-CNST-J: Submit a Noise Control Plan and a Noise Monitoring Plan**

Require the contractor to submit to the Resident Engineer a Noise Control Plan and a Noise Monitoring Plan, prepared by a qualified Acoustical Engineer. The qualifications and activities of the Acoustical Engineer will be subject to approval of the Resident Engineer. The Noise Control Plan will be updated every 3 months and include all the pertinent information about the equipment and the construction site layout, the projected noise levels, and the noise mitigation measures that may be required to comply with the noise limits for each sensitive receptor. The Noise Monitoring Plan will outline the equipment and procedures used by the contractor to perform noise measurements and to identify noise-sensitive structures in the immediate vicinity of construction operations,

including details regarding the noise measurement locations. The results of noise monitoring will be documented and submitted to the Resident Engineer weekly. In the event that levels exceed allowable limits, the Resident Engineer will ensure that contractually required corrective measures consistent with the Noise Control Plan are implemented.

**Mitigation Measure NV-CNST-K: Require Minimum Qualifications for the Acoustical Engineer**

The minimum qualifications for the Acoustical Engineer will be a Bachelor of Science or Engineering degree, from a qualified program in engineering or physics offered by an accredited university or college, and 5 years in noise control engineering and construction noise analysis.

**Mitigation Measure NV-CNST-L: Prohibit Operation of Noise-Generating Equipment Prior to Acceptance of Noise Monitoring Plan and Noise Control Plan**

Require that the contractor not operate noise-generating equipment at the construction site prior to acceptance of the Noise Monitoring Plan and the Noise Control Plan.

**Mitigation Measure NV-CNST-M: Install permanent Noise Monitors at the Downtown San Jose and Diridon Station during all Construction Phases**

Require the contractor to install stationary noise monitors at the Downtown San Jose Station and Diridon Station during all the construction phases, sampling noise continuously at two monitoring locations at each station. The monitoring locations may be moved as the construction site progresses. At the Alum Rock/28<sup>th</sup> Street Station and the West Portal staging area, stationary noise monitors will also be initially installed, which may be removed if the noise levels are in compliance with the noise limits when the construction activities are closest to the sensitive receptors. All data gathered by the contractor will be continuously available to the VTA and submitted weekly to the Resident Engineer for approval.

In addition to these stationary noise monitors, 30-minute noise sampling with hand-held monitors will be required weekly at the station sites and at other construction sites, including the ventilation shafts and gap breaker stations, to ensure compliance with the noise criteria. If required, additional noise monitoring site(s) may be added by the Resident Engineer to address any specific situation and concern. Noise data will be submitted to the Resident Engineer for approval on a weekly basis, and will include details on location and type of construction activity and details, photographs, and sketches of noise monitoring locations. A qualified acoustical engineer will determine whether work was within thresholds or not, and indicate any steps taken during monitoring to lower noise levels.



### **Mitigation Measure NV-CNST-N: Ensure Equipment is Pre-certified to Meet Noise Limits**

For major equipment to be used at the surface of the construction site for a total duration greater than 5 days, ensure that the equipment is pre-certified by the Acoustical Engineer during field measurements at a test site or guaranteed by the equipment vendor to meet the noise limits developed for construction equipment as shown in Table 5-8. The final limits to be applied will be re-examined and developed during final design, and verified by the contractor during initial and active performance of the work when the equipment arrives on site. Construction equipment will be retested at 6-month intervals while in use onsite. Any equipment used during construction may be subject to confirmatory noise level testing while performing the work at the request of the Resident Engineer.

**Table 5-8: Noise Emission Limits for Construction Equipment**

<b>Equipment Type</b>	<b>Typical L<sub>max</sub> Sound Level at 50 feet dBA</b>
Excavators	82
Dump trucks	81
Front end loaders	81
Dozers	82
Concrete trucks	77
Cranes	81
Backhoes	75
Compactors	77
Concrete pumping trucks	77
Small construction vehicles (pickup trucks)	68
Large and small diameter auger drill rigs	81
Diesel generators	69 <sup>a</sup>
Flat-bed semi-trucks	81
Diesel pumping equipment	77
Compressed-air construction tools	81
Rail welding plant	77
Air compressors	70 <sup>a</sup>
Muck conveyor	70
Grout batch plant	80
Welding equipment	73
Grout silos	70
Grout mixers	71
Grout pumps	77
Source: HNTB Companies 2006.	
<sup>a</sup> Assumed acoustically treated	

**Mitigation Measure NV-CNST-O: Implement a Complaint Resolution Procedure**

A complaint resolution procedure will be put in place to rapidly address any noise and vibration problems that may develop during construction. After a complaint is received, the complaint will be assigned a case number and the person making the complaint contacted to receive further clarification on the concern. The issue will then be discussed with the construction team to determine the appropriate action to resolve the issue. The person making the complaint will then be contacted to describe how the issue has been resolved.

**Mitigation Measure NV-CNST-P: Conduct Construction Vibration Monitoring**

The contractor will initially conduct vibration monitoring daily at the nearest affected buildings (within 100 feet of any building) during any construction activities that could induce vibration.

Monitoring will be performed continuously at the closest receptor during all demolition and construction activities to ensure vibration levels will not exceed the FTA construction vibration damage criteria for applicable building type, as follows: 0.12 PPV (inches/second) for historic buildings and those buildings extremely susceptible to vibration damage, 0.2 PPV (inches/second) for non-engineered timber and masonry buildings, 0.3 PPV (inches/second) for engineered concrete and masonry (no plaster) buildings and 0.5 PPV (inches/second) for reinforced-concrete, steel or timber (no plaster) buildings.

Vibration will be measured in the vertical direction on ground surface or building floor and measured continuously to ensure that peak vibration-generating construction is captured. Vibration will be compared against both structural and nuisance thresholds in terms of velocity levels in  $\text{dB re } 10^{-6}$  inches/second or PPV. If the measured vibration data are in compliance with the vibration limits after work has completed start-up and entered full-production mode (typically within 2 weeks to 30 days), vibration monitoring may be performed once a week instead of daily if approved by VTA. Daily monitoring will be performed during a continuous 8-hour work shift during the closest and most vibration-inducing work.

**Mitigation Measure NV-CNST-Q: Perform Vertical Direction Vibration Monitoring**

The contractor will perform continuous vertical direction vibration (root mean square) monitoring on the ground at the nearest representative residential structure during muck extraction and supply train operations in the tunnels. These measurements should be repeated for a minimum of 1 week at approximately 1-mile intervals along the tunnel construction until it is demonstrated that the levels are below the FTA thresholds.

### **Mitigation Measure NV-CNST-R: Require Monitoring of Vibration for Peak Particle Velocity**

A survey of structures potentially impacted by construction vibration will be conducted prior construction and submitted for the Resident Engineer's approval. Vibration for PPV will then be monitored continuously at the closest structures and where vibration is expected to approach the applicable limit based on the building type and condition.

### **Mitigation Measure NV-CNST-S: Implement Measures to Reduce Vibration from Muck Extraction and Supply Trains**

The construction contractor will be required to implement measures such that muck extraction and supply train operations do not result in groundborne noise in excess of 72 VdB at nearby residences. Measures that can be implemented include but are not limited to placement of ballast mats underneath tracks on which the muck extraction train rides or use of a conveyor in place of a train.

## **5.5.14 Security and System Safety**

The safety of construction workers and others in the vicinity of construction activities could be affected by accidents or unsafe practices during construction. Construction activities will align with local- and state-recognized safety practice requirements. Fencing and lighting of construction zones will be implemented to avoid accidents. Safety plans will be designed to account for worksite traffic control, pedestrian and bicyclist access, and handling of potential hazardous or contaminated materials. The construction manager will be responsible for job site safety and security during construction.

Emergency response personnel within the cities of San Jose and Santa Clara would be notified of construction activities and any incidents that need emergency response. Emergency response personnel would also be notified of any transportation network disruptions or temporary detours to ensure that they will be available for immediate response on an as-needed basis. There would be *no adverse effect*, and mitigation is not required.

## **5.5.15 Socioeconomics**

Construction of the BART Extension would require property acquisitions and resultant displacements from acquiring the underlying property in whole or in part. Property acquisition and resultant displacements would occur prior to the start of construction. For a map of the project footprint, refer to Appendix B, *Project Plans and Profiles*, and Appendix C, *BART Station Site Plan Concepts*. For a detailed discussion about displacements, refer to Chapter 4, Section 4.14, *Socioeconomics*.

Construction of the BART Extension Alternative has the potential to adversely affect traffic, transit, and parking, which could disrupt access to public facilities, businesses, and residences as described in Section 5.5.2, *Transportation*. Residents, businesses, and visitors

along the alignment would also be subject to noise, dust, vibration, and emissions from construction equipment during construction. These impacts could discourage or restrict pedestrian activity along the blocks under construction and reduce foot traffic, which could potentially impact local businesses through lost revenues. In addition, on-street parking availability within the study area would be limited during construction. Vehicular traffic and parking effects are outlined in Section 5.5.2, *Transportation*. Community members would experience construction-related effects for several years and, in some cases, up to 8 years until the BART Extension is in operation. Additionally, construction would require acquisition of right-of-way, which would result in the displacement of several businesses and one residence located within the BART Extension footprint. Existing business types and notable facilities near proposed BART Extension components are described below.

- **Alum Rock/28<sup>th</sup> Street Station:** the area surrounding the proposed station includes mostly small retail and light industrial establishments. Additionally, the Portuguese Band and Social Center is on the west side of the site, and the Five Wounds National Portuguese Church and the Cristo Rey San Jose Jesuit High School are southeast of the site. Although several roads would be closed during construction, access to nearby businesses and the school would be maintained.
- **Tunnel Alignment near Coyote Creek:** the area surrounding the proposed 13<sup>th</sup> Street Ventilation Facility includes restaurants, pharmacies, and other commercial businesses. The alignment would be mostly underground in this area, but the aboveground ventilation facility would require lane closures, detours, etc.
- **Downtown San Jose Station East Option:** the San Jose First United Methodist Church, Our Lady of La Vang Parish, and First Presbyterian Church are near the Downtown San Jose Station East Option. Nearby restaurants, sandwich shops, coffee shops, and bars cater to employees in the surrounding offices. A grocery store, several salons, jewelry stores, clothing stores, and other stores occupy much of the ground-level frontage along Santa Clara Street near the station area. Horace Mann Elementary School is also along Santa Clara Street between 6<sup>th</sup> and 7<sup>th</sup> Streets. Construction of the station and associated CSAs would require lane, street, and sidewalk closures. Additionally, construction would remove off-street parking spaces (most located at VTA's Mitchell Block property off Market Street) and on-street publicly available parking spaces.
- **Downtown San Jose Station West Option:** a mixture of offices, banks, retail stores, bars, and restaurants are located near the Downtown San Jose Station West Option. The Trinity Cathedral, Daughters of Zion Ministries, and First Presbyterian Church are churches near the proposed station. A pharmacy, several salons, jewelry stores, clothing stores, and other stores occupy much of the ground-level frontage along Santa Clara near the station. Construction of the station and associated CSAs would require lane, street, and sidewalk closures. Additionally, construction would remove off-street parking spaces (most located at VTA's Mitchell Block property off Market Street) and on-street publicly available parking spaces.

- **Diridon Station South and North Options:** several restaurants are located near the SAP Center. Offices and industrial businesses are located near South Montgomery Street and Autumn Street and typically operate during normal business hours. During construction of Diridon Station, off-street and on-street publicly available parking spaces would be removed in the area bounded by Santa Clara Street/The Alameda to the north, San Fernando Street to the south, Los Gatos Creek to the east, and the railroad corridor to the west. Construction would also require full and partial closures of Autumn, Montgomery, and Cahill Streets south of Santa Clara Street.
- **Continuation of Tunnel Alignment:** many retail shops, restaurants, offices, pharmacies, grocery stores, and light industrial businesses exist along this portion of the alignment. Pockets of restaurants and bars increase where the alignment is closer to Downtown San Jose and the SAP Center. Several auto-part and light industrial stores are in this area as well. The alignment would be underground along this portion of the BART Extension. Near Stockton Avenue and south of Taylor Street, there are three alternate locations for the Stockton Avenue Mid-Tunnel Ventilation Facility. Construction activities for the Stockton Ventilation Facility include short-term lane closures.
- **End-of-the-Line Newhall Maintenance Facility:** the existing restaurants surrounding the end-of-the-line Newhall Maintenance Facility include a few on the west side of the Caltrain tracks off El Camino Real. The Avaya Stadium and a commercial shopping center is near the facility. Newhall Drive is in the vicinity of Avaya Stadium, but no stadium access or parking is allowed from this street. Construction vehicles would use Brokaw Road and Newhall Drive, which may require lane closures and detours.
- **Santa Clara Station:** existing businesses surrounding the Santa Clara Station include larger box-type retail, a dentist office, and several other small offices and restaurants. All of these establishments have off-street parking lots for their employees and patrons. The area surrounding Santa Clara Station is largely residential on the west side of El Camino Real and is close to Santa Clara University. Construction would require access to Brokaw Avenue, which is a dead-end road that also provides access to Costco and other businesses. The eastern half of Brokaw Road would remain open to vehicular traffic, and therefore access to the businesses would not be reduced.

Construction of the BART Extension would result in disruptions to nearby businesses and a potential loss of income while access is limited and detoured. These effects would be experienced across the entire study area, but vary in severity based on location and also type of tunnel boring method chosen. Compared to the Twin-Bore Option, the Single-Bore Option would involve less cut-and-cover excavation at the stations and would thereby result in less disruption to pedestrian and vehicular access. Overall, construction of the BART Extension would be disruptive to the local community. VTA will work with property and business owners to minimize disruption and maintain access throughout construction.

Although construction activities would cause disruptions for both tunnel options, VTA would ensure traffic, bicycle, and pedestrian traffic would be maintained to the extent feasible or



re-routed. The severity of these effects would be reduced by adherence to regulations and implementation of mitigation. VTA will work with property and business owners to minimize disruption and maintain access throughout construction and would implement Mitigation Measure TRA-CNST-A, as described in Section 5.5.1, *Construction Education and Outreach Plan*. Mitigation Measure TRA-CNST-A would implement an extensive outreach program to notify the public of upcoming construction activities and provide frequent updates, a dedicated onsite outreach coordinator, and 24-hour hotline. The overall intent of Mitigation Measure TRA-CNST-A is to coordinate construction activities with existing business operations and other development projects and to establish a process that will adequately address the concerns of businesses and their customers, property owners, residents, and commuters. VTA will work with property owners and business owners in the station areas to maintain access to businesses during construction to the extent feasible. VTA will also implement Mitigation Measure TRA-CNST-C and work with the City of San Jose to develop parking management strategies to encourage multi-modal access to the Downtown San Jose area. Construction of the BART Extension Alternative would also provide work opportunities for the community, which would be beneficial for the local economy. Additionally, mitigation measures for air quality (Mitigation Measures AQ-CNST-A through AQ-CNST-I) and noise construction (Mitigation Measures NV-CNST-A through NV-CNST-S) would reduce potential effects on businesses (see Sections 5.5.3 and 5.5.13, respectively) except for construction noise impacts at the Downtown San Jose and Diridon Stations.

Given the long period of construction (see Table 5-2 for Twin-Bore construction durations) and potential for disruption to access for local businesses in Downtown San Jose, socioeconomic impacts are considered *adverse* during construction. The severity of the impacts would be greater for the Twin-Bore Option than for the Single-Bore Option due to the more extensive cut-and-cover station and crossover construction proposed under the Twin-Bore Option that would require major street and lane closures.

Construction would be disruptive to the local community and those that travel to Downtown San Jose for work under both the Twin-Bore and Single-Bore Options. Roadway and sidewalk closures would be most disruptive during peak commute times during the day from bus rerouting, bus stop relocation, loss of parking, and vehicular accessibility. While road closure may affect vehicle access, many of the Downtown businesses cater to employees in the surrounding offices and rely heavily on pedestrian access. Pedestrian traffic may decrease due to limited access during construction. However, VTA will maintain pedestrian access whenever feasible and will work with property and business owners to minimize disruption of access to businesses during construction. Additionally, construction workers may become new customers to businesses, which may help to offset construction impacts. VTA will work with property and business owners to minimize disruption and maintain access throughout construction.

While construction would be phased with not all impacts happening at once or at one location, and although VTA will implement a comprehensive Construction Education and

Outreach Plan, construction impacts would last for up to 8 years. Construction activities would adversely impact the local business community.

Construction activities would provide employment opportunities for the local community. In addition, according to FTA Circular 4220.1F – Third Party Contracting Guidance, each FTA recipient must comply within applicable Federal laws and regulations that provide competitive opportunities for a contractor that qualifies as a disadvantaged business enterprise (DBE), minority-owned firm, women’s business enterprise, or small business. Therefore, implementation of the BART Extension Alternative would create economic benefits for disadvantaged contracting firms that meet such criteria during construction. VTA’s BART Silicon Valley—Berryessa Extension Project, or Phase I Project, also followed such requirements, including an 18 percent DBE goal.

Although operation of the BART Extension would have a long-term beneficial effect on the community and business viability by increasing regional mass transit access and reducing air pollutant emissions, the estimated construction duration of 8 years and associated disruptions to the Downtown San Jose area would result in a short-term *adverse effect* on socioeconomics during construction.

## 5.5.16 Utilities

This section focuses on short-term, temporary impacts on utilities during construction activities. Permanent impacts on utilities are discussed in Chapter 4, Section 4.15.

### 5.5.16.1 Relocation of Existing Utilities

The major existing utilities within the alignment are water, stormwater and sanitary sewer lines, electric and gas lines, and communications facilities. Water lines within the alignment are owned and operated by the San Jose Water Company, San Jose Municipal Water System, City of San Jose, City of Santa Clara, and Santa Clara Valley Water District (SCVWD). The stormwater lines, storm drains, and sanitary sewers in the alignment are maintained by the City of San Jose, City of Santa Clara, and SCVWD. PG&E controls the electric and gas facilities in San Jose. In the city of Santa Clara, Silicon Valley Power owns and operates the electrical facilities. The communications facilities in the corridor are owned and operated by Sprint, Verizon (formerly MCI/MFS), Level 3, XO Communications, City of San Jose, AT&T (formerly SBC), Qwest, and Comcast. Table 5-9 identifies the location, quantity, type of utility, owner/operator, size, and type of materials of the major utility lines that are at least 36 inches in diameter along the BART Extension alignment.

**Table 5-9: Major Utility Locations along the BART Extension Alignment (36-inch diameter and greater)**

Location	Quantity	Type of Utility	Owner/Operator	Size (inches)	Type of Materials
9 <sup>th</sup> and Santa Clara Streets	1	Sanitary Sewer	City of San Jose	48	Vitrified Clay Pipe
7 <sup>th</sup> and Santa Clara Streets	1	Storm Drain	City of San Jose	72	Reinforced Concrete Pipe
6 <sup>th</sup> and Santa Clara Streets	1	Storm Drain	City of San Jose	72	Reinforced Concrete Pipe
5 <sup>th</sup> and Santa Clara Streets	2	Sanitary Sewer	City of San Jose	54 and 60	Reinforced Concrete Pipe
5 <sup>th</sup> and Santa Clara Streets	1	Storm Drain	City of San Jose	54	Reinforced Concrete Pipe
4 <sup>th</sup> and Santa Clara Streets	1	Storm Drain	City of San Jose	60	Reinforced Concrete Pipe
Autumn Street	1	Sanitary Sewer	City of San Jose	36	Reinforced Concrete Pipe
Emory Street	1	High-Pressure Water	Santa Clara Valley Water District	66	Prestressed Concrete and Steel
Hedding Street Bridge	1	Sanitary Sewer	City of San Jose	42	Vitrified Clay Pipe
Mckendrie Street (closed)	1	Storm Drain	City of San Jose	66	Reinforced Concrete Pipe
Mckendrie Street (closed)	1	Sanitary Sewer	City of San Jose	48	Reinforced Concrete Pipe
Parallel to I-880 (crossing UPRR tracks)	1	Storm Drain	City of San Jose	48	Reinforced Concrete Pipe
Brokaw Road	3	Storm Drain	City of Santa Clara	36	Reinforced Concrete Pipe
East of De La Cruz Overcrossing	1	Storm Drain	City of Santa Clara	60	Reinforced Concrete Pipe
East of De La Cruz Overcrossing	1	Storm Drain	City of Santa Clara	42	Reinforced Concrete Pipe

Source: VTA 2016.

## City of San Jose

The following major utilities were identified within San Jose.

- Communications facilities at the PG&E substation near Newhall Street and Stockton Avenue are owned and operated by AT&T and Level 3.

To the extent possible, the BART Extension has been located to avoid conflicts with these major utilities. Nonetheless, some underground utilities would need relocation or reinforcement to enable construction of the BART Extension stations, alignment, and ancillary facilities. This is particularly true for the tunnel segments and stations to be constructed by the cut-and-cover method, specifically Alum Rock/28<sup>th</sup> Street, Downtown San Jose (East and West Options), and Diridon (South and North Options) Stations.

Utilities to be relocated would include storm drains, sanitary sewers, water mains, electricity and gas lines, and communication lines. Buried utilities, with the possible exception of sewers, are generally found within several feet of the street surface. Utilities within the subsurface construction area not in need of relocation would be uncovered and protected during the early stages of excavation.

For the tunnel alignment, utilities in physical conflict with the permanent or temporary structures (cut-and-cover boxes for the portals and stations for the Twin-Bore Option, ventilation shafts, temporary roadway decking, and bore tunnels) of the BART Extension Alternative would require relocation. The major utility relocations for the four primary cut-and-cover excavations along the tunnel alignment would be as follows.

- For the Twin-Bore Option, two sanitary sewer mains would be in conflict with the cut-and-cover box for the east tunnel portal and would be relocated to the south of the portal above the bore tunnel.
- A storm drain would be in conflict with the Alum Rock/28<sup>th</sup> Street Station, a traction power substation, and parking garage. The storm drain would be relocated to avoid these structures. The northeasterly end of the Alum Rock/28<sup>th</sup> Street Station would encroach into the Caltrans ROW and adversely affect another storm drain. This storm drain would require relocation prior to construction of the station box.
- Several communications duct banks with associated vaults, electrical ducts and vaults, gas lines, water lines, storm drains, and sanitary sewers would be in conflict with the Downtown San Jose Station. Most of these utilities would require reconstruction and/or relocation.
- A sanitary sewer line would be in conflict with the Diridon Station box (South and North Options) and would be relocated to the east end of the station. In general, other utilities crossing the Diridon Station at South Autumn Street, South Montgomery Street, and Cahill Street would be supported in place during construction but not relocated.
- For the Twin-Bore Option, a sanitary sewer and a storm drain would in conflict with the cut-and-cover box for the west tunnel portal and would be relocated to the south of the portal above the bore tunnel.

In addition, the Santa Clara Station, pedestrian access tunnel, and Newhall Maintenance Facility require careful attention with regard to utilities. At these facilities, utilities would be protected in place or relocated horizontally and/or vertically. In general, all existing UPRR utilities within the Newhall Maintenance Facility ROW would be abandoned and removed. In the tail track area of the Newhall Maintenance Facility, a 60-kilovolt overhead electric line would be relocated to a location outside the ROW. Also in the tail track area, two communication towers would be relocated outside of the alignment. A communications line that would conflict with the vehicle turntable, non-revenue maintenance and engineering shop, and Santa Clara Station would be relocated to near Newhall Street. Utilities along Brokaw Road would be relocated as necessary to accommodate road widening for station

access. Finally, an existing Silicon Valley Power Substation would be relocated within the Newhall Maintenance Facility site.

Relocation of utilities to new permanent locations generally would be performed in advance of construction. Ongoing coordination with utility providers would be conducted during the Final Design and Engineering and construction phases to identify and overcome potential conflicts. If necessary, disruptions would be short term and carefully scheduled with advance notice given to affected customers. To avoid or minimize disruptions in service, the following practices would be implemented.

- VTA would continue to coordinate with utility providers throughout the design and construction phases of the BART Extension Alternative to locate existing utilities, identify potential conflicts in the construction area, and formulate strategies to avoid unscheduled service interruptions.
- A set of detailed plans for the BART Extension Alternative would be submitted to utility providers for their review and comment prior to the onset of any utility relocation work.
- Underground utilities that do not need to be relocated either temporarily or permanently would be uncovered and reinforced, if necessary, and supported in place during construction by hanging from support beams spanning across the excavation.
- Property owners, residences, and businesses would be notified of major utility relocations.

Implementation of these above practices would result in there being *no adverse effect* on utility service.

The Single-Bore Option would be substantially deeper than the Twin-Bore Option and therefore require fewer utility relocations. Therefore, the Single-Bore Option construction activities would similarly result in *no adverse effect*.

## 5.5.16.2 Impacts on Utilities and Service Systems

### Stormwater and Sanitary Sewer Demand

Groundwater encountered during BART Extension construction would be pumped from the excavation zone and tested for contaminants. Uncontaminated groundwater would be discharged into the storm or sanitary sewer system. Contaminated groundwater would receive onsite treatment and/or disposal at a permitted offsite facility in accordance with applicable laws and regulations. This process may increase wastewater flows to the San Jose/Santa Clara Water Pollution Control Plant (WPCP), which is the wastewater treatment provider serving the BART Extension. However, construction-related groundwater discharge into the sanitary sewer system would be temporary and would not permanently affect capacity at the WPCP. There would be *no adverse effect*.



## Water Demand

Water trucks would be required on construction sites for routine dust control. Water required for dust control would be sourced from local water providers, and represents a temporary demand on their supply. There would be *no adverse effect*.

## Solid Waste Demand

BART Extension construction would generate solid waste requiring special consideration, such as material extracted during tunnel boring. Excavation of the underground station structures and tunnel portals/corridors is expected to generate approximately 1,450,000–1,520,000 cubic yards of material with the Twin-Bore Option and approximately 1,830,000 cubic yards of material with the Single-Bore Option. Soils extracted during tunnel construction would be tested for contaminants and disposed of in accordance with all applicable regulations, as determined by VTA's Contaminant Management Plan as discussed in Chapter 6, Section 6.10, *Hazards and Hazardous Materials*.

Demolition of existing structures, buildings, pavement, and other site features would primarily occur at the four stations, two mid-tunnel ventilation structure sites, and two tunnel portals. The BART Extension would be required to divert at least 75 percent of demolition debris in San Jose and 50 percent of demolition debris in Santa Clara to comply with local Construction and Demolition Diversion/Recycling programs. Remaining debris would be hauled to landfills serving the construction area.

The Newby Island Landfill and Kirby Canyon Landfill currently service San Jose. The Newby Island Landfill has a remaining capacity of approximately 21.2 million tons of solid waste, and the Kirby Canyon Landfill has a remaining capacity of approximately 21.6 million tons of solid waste. Construction and demolition debris generated in San Jose would represent a not adverse effect on either landfill, which each have sufficient capacity to handle demolition debris generated by construction of the BART Extension in San Jose. The Newby Island Landfill also services Santa Clara. Construction and demolition waste associated with construction of the BART Extension in Santa Clara would have *no adverse effect* on the Newby Island Landfill.

The above discussion would apply to both the Twin-Bore and Single-Bore Options.

### 5.5.17 Visual Quality and Aesthetics

Construction of the BART Extension Alternative under both the Twin-Bore and Single-Bore Options would involve the use of heavy equipment, stockpiling of soils and materials, and other visual signs of construction. In general, construction impacts include the visual presence of construction equipment, light and glare impacts from any nighttime construction work, and newly disturbed natural land cover that would recover to its original undisturbed form. Such effects would be somewhat more pronounced in residential areas or areas seen by substantial numbers of passing motorists, pedestrians, and bicyclists. Several CSAs have been identified along the alignment, as described in Section 5.2.4.1, *Construction Staging*

*Areas.* Five of the proposed CSAs are within or adjacent to residential neighborhoods that would be the most sensitive to light and glare impacts. These CSAs include the Alum Rock/28<sup>th</sup> Street Station site, 13<sup>th</sup> Street ventilation structure site, Downtown San Jose Station East Option site, the Stockton ventilation structure site, and the Newhall Maintenance Facility site. Both of the proposed CSAs for the Downtown San Jose Station East and West Options would be on Santa Clara Street, a busy retail, commercial, and business thoroughfare that traverses Downtown San Jose and experiences high numbers of visitors.

To minimize the signs of construction, visual screening techniques would be implemented at construction sites as appropriate. Construction areas would be maintained in an orderly manner, including proper containment and disposal of litter and debris to prevent dispersal onto adjacent properties and roadways. Construction crews working at night would direct any artificial lighting onto the work area to minimize the spillover of light or glare onto adjacent areas.

Short-term visual changes as a result of construction are a common and accepted feature of urban and suburban areas. Visual screening and other techniques designed to reduce visual effects will be provided during construction. Trees that are removed during construction will be replaced along the alignment. In accordance with local policies as applicable, Mitigation Measure AES-CNST-A addresses tree removal that would comply with the overall intent and spirit of local tree ordinances. Tree replacement would also adhere to VTA's Sustainable Landscaping Policy.

With implementation of this mitigation measure, the BART Extension Alternative, including both the Single-Bore Option and the Twin-Bore Option, would result in *no adverse effect* after mitigation.

### **Mitigation Measure AES-CNST-A: Replace Trees**

Trees that will be removed due to construction activities will be inventoried and noted on construction plans before construction begins. Any trees that are removed will be compensated for according to the following ratios.

All urban trees that are to be removed or lost as a result of the BART Extension will be replaced along the alignment, to the extent feasible. Trees with a diameter of less than 12 inches will be replaced at a 2:1 ratio. All trees with a diameter of 12 inches or more will be replaced at a 3:1 ratio. If urban trees (nonnatives and ornamentals) are replaced with native trees, a reduced mitigation ratio of 1:1 for all trees smaller than 12 inches in diameter, and 2:1 for all trees with a diameter of 12 inches or more, will be implemented. These trees will be irrigated and maintained for a period of no less than 3 years. If VTA cannot replace trees at the stated ratios along the alignment, VTA will pay in-lieu fees.

## 5.5.18 Water Resources, Water Quality, and Floodplains

Additional information related to potential construction effects on water resources is found in Sections 5.5.4 and 5.5.11 above for biological resources and hazardous materials, respectively.

### 5.5.18.1 Surface Waters

Implementation of the BART Extension would include construction activities, such as site clearing, new building construction and demolition, paving and repaving for parking lot and transit center expansion, cut and fill activities, grading and excavation, and landscaping. These land-disturbing activities and placement of stockpiles close to storm drain inlets may also result in a temporary increase in sediment loads to the Lower San Francisco Bay. Sediment transport to local drainage facilities such as drainage inlets, culverts, and storm drains could also result in reduced storm flow capacity, resulting in localized ponding or flooding during storm events.

The delivery, handling, and storage of construction materials and wastes (e.g., concrete debris), as well as the use of heavy construction equipment, could also result in stormwater contamination, and thereby affect water quality. Construction activities may involve the use of chemicals and operation of heavy equipment that could result in accidental spills of hazardous materials (e.g., fuel, oil) that could enter the groundwater aquifer or nearby surface water bodies via runoff or storm drains. A spill prevention and cleanup plan would be included in the Storm Water Pollution Prevention Plan (SWPPP) to address these potential impacts.

All construction activities would be subject to existing regulatory requirements. Because the land disturbance for the BART Extension would be more than 1 acre, coverage under the Construction General Permit would be required. The Construction General Permit contains standards to ensure that water quality is not degraded. As part of compliance with the Construction General Permit, standard erosion control measures and other best management practices (BMPs) would be identified in a SWPPP. These measures would be implemented during construction to reduce contamination and sedimentation of waterways.

Construction activities could result in short-term surface and groundwater quality impacts, such as input of sediment loads that exceed water quality objectives or chemical spills into storm drains or groundwater aquifers if proper minimization measures are not implemented. However, the BART Extension will include development and implementation of a SWPPP specific to the BART Extension and would be in compliance with the Construction General Permit, local stormwater ordinances, and other related requirements. In addition, the BART Extension would also include implementation of Mitigation Measure BIO-CNST-D, through which the VTA would design all BART Extension facilities to avoid temporary and permanent adverse effects on riparian habitat to the maximum extent practicable (see Section

5.5.4, *Biological Resources and Wetlands*). Therefore, there would be *no adverse effects* on water quality from construction activities.

Construction activities would alter existing drainage patterns and could result in local (onsite) and temporary erosion and siltation. Although drainage patterns on the BART Extension would be altered, drainage would ultimately be improved due to new drainage systems likely being required to capture drainage and stormwater management measures and low-impact development (LID) techniques such as increased pervious surfaces, bioswales, and raingardens being considered for the BART Extension. These features would further minimize runoff volumes and the potential for ponding and other drainage issues onsite.

Preparation and implementation of the Grading and Erosion Control Program and the SWPPP would reduce the potential for substantial erosion or siltation onsite or offsite, or flooding onsite or offsite as a result of altering existing drainage patterns, or substantially increase the rate or amount of runoff that would result in substantial erosion, siltation, or flooding onsite or offsite. The BART Extension would be in compliance with existing NPDES permits and the cities of San Jose's and Santa Clara's Storm Water Permits and Regulations as required. Additionally, construction of the BART Extension would not involve work within surface waters, and thus would not alter the course of an existing stream or river. The effects would be not adverse.

New and renovated facilities would be drained by a combination of existing, new, and modified storm drains. Although the BART Extension would increase total impervious surface area relative to existing conditions, drainage improvements and LID measures would be implemented, which would ultimately reduce the volume of stormwater runoff into the storm drain system.

The final design for the stormwater management and storm drainage system would be required to meet several criteria (e.g., Phase II Municipal Separate Storm Sewer System Permit criteria and 100-year flood criteria) to ensure sufficient storm drain capacity for the BART Extension. Therefore, runoff water due to the BART Extension would not exceed the capacity of existing or planned stormwater drainage systems, and there would be *no adverse effects*.

The Single-Bore Option would not involve cut-and-cover aboveground construction except at entrances and system facilities, and, therefore, less surface drainage storm waters would be potentially disturbed compared to the Twin-Bore Option. The Single-Bore Option would similarly have *no adverse effects*.

### **5.5.18.2 Floodplains**

Alum Rock/28<sup>th</sup> Street Station, Downtown San Jose Station (East and West Options), and Diridon Station (South and North Options) would be underground and therefore would not extend into a floodplain. The Santa Clara Station would be aboveground. However, the Santa

Clara Station would be within flood Zone X (an area of moderate flood hazard), and no BART Extension features would be within the 100-year floodplain.

Some of the staging areas would be within the base floodplains. However, these areas would be used only temporarily during construction of the BART Extension. It is anticipated that they would not result in permanent impacts on the base floodplain; therefore, mitigation is not required.

Compliance with SWPPP would ensure that construction activities do not result in alteration of surface runoff rates such that localized flooding would occur. There would be *no adverse effects*.

The Single-Bore Option would not involve cut-and-cover aboveground construction except at entrances and system facilities. Therefore, compared to the Twin-Bore Option, there is less potential for localized flooding during construction. The Single-Bore Option impacts on floodplains would similarly result in *no adverse effects*.

### 5.5.18.3 Groundwater

This section focuses on potential hydrogeological changes to groundwater. While contamination of groundwater is also included in the discussion, refer to Section 5.5.11, *Hazards and Hazardous Materials*, for a more complete discussion of effects related to contaminated groundwater.

The groundwater table is anticipated to be encountered during the excavation for construction of the underground stations and tunnel structures. As a result, dewatering of the shallow groundwater zone would be required during excavation activities. However, the BART Extension would not substantially deplete groundwater supplies or substantially interfere with groundwater recharge because it would not increase groundwater demand or decrease groundwater recharge areas. Although dewatering may be necessary during construction, methods to address dewatering include a well-based dewatering system and/or the pumping of water from the excavation using pumps in low spots. As a result, there is potential for reducing the volume of water in the local aquifer table. However, dewatering would be on a temporary basis during the construction phase and would not result in a loss of quantities of water that would deplete groundwater supplies.

A Dewatering Plan would be required as part of the SWPPP for any dewatering proposed up to 10,000 gallons per day. In addition, construction in the tunnels would adhere to the SCVWD 2012 Groundwater Management Plan, and would protect groundwater from existing and potential contamination. Prior to any discharge into the sanitary sewer, storm drainage system, or downstream receiving water bodies, water quality sampling and analysis would be required. For areas of known contamination and where pumping would exceed 10,000 gallons per day, the Construction General Permit may not be used for dewatering and a separate NPDES permit for Structural Dewatering, volatile organic compound–contaminated groundwater, and/or a BART Extension-specific Waste Discharge

Requirements permit will be needed to address potential contamination of groundwater and treatment needed prior to discharge.

Water supply for construction activities (e.g., dust control, concrete mixing, material washing) would come from nearby hydrants or existing surface supplies to the site, trucked to the site or from dewatering effluent, if appropriate. As discussed above in Section 5.5.11, Mitigation Measure HAZ-CNST-A would be implemented, ensuring that site-specific RAPs are prepared and implemented to reduce impacts on the environment, including groundwater that could result from the disturbance of hazardous materials in soil and ballast materials during construction. Therefore, there would be no potential for reducing the volume of water in the local aquifer table, and the impact on groundwater supplies from construction activities would result in *no adverse effects*. No mitigation is required.

The Single-Bore Option impacts would similarly result in *no adverse effects*.

## 5.5.19 Environmental Justice

Construction of the BART Extension Alternative would require acquisition of right-of-way, which would result in the displacement of several businesses and one residence. The right-of-way needs are described in Section 4.14, *Socioeconomics*. Many of these displacements and relocations would occur within low-income and minority populations. Additionally, the BART Extension Alternative may also have associated construction-related effects on the community from air quality, hazards, noise and vibration, traffic, and visual changes. While construction activities are projected to last for approximately 8 years, community members would experience construction-related effects intermittently depending on the phase of construction.

### 5.5.19.1 Discussion of No Adverse Effects

The resource topic below would have *no disproportionately high and adverse effect* on environmental justice populations.

#### Electromagnetic Fields and Electromagnetic Interference

No construction adverse effects were identified for EMF generation; therefore, no disproportionately high and adverse effects would occur for environmental justice communities and this topic is not discussed further.

### 5.5.19.2 Discussion of Potential Adverse Effects

A *disproportionately high and adverse effect* on environmental justice populations could occur if, the effect:

1. Is predominately borne by a minority population and/or a low-income population, or



2. Will be suffered by the minority population and/or low-income population and is appreciably more severe or greater in magnitude than the adverse effect that will be suffered by the non-minority population and/or non-low-income population.

The following subsections discuss the potential adverse effects of the BART Extension Alternative identified in this document and analyzes whether these effects would constitute disproportionately high and adverse effects on environmental justice populations. It should be noted that Mitigation Measure TRA-CNST-A (Develop and Implement a Construction Education and Outreach Plan) would apply and be designed to address all of the environmental topic areas below.

## Air Quality

As described in Section 5.5.3, *Air Quality*, construction associated with the BART Extension would generate criteria pollutant emissions from the following construction activities: (1) utility relocation for underground and overhead utilities along the corridor; (2) site preparation/excavation related to the three underground stations, specifically Alum Rock/28<sup>th</sup> Street, Downtown San Jose (East and West Options), and Diridon (South and North Options); (3) cut-and-cover operations and excavation of tunnels by use of one or more TBMs; (4) demolition of existing structures, buildings, pavement, and other site features; (5) construction of ventilation facilities, system facilities, station box, track work including crossovers, station campuses, and the Newhall Maintenance Facility; (6) construction workers traveling to and from construction sites; and (7) delivery of construction supplies to construction sites and hauling of debris from construction sites. These construction activities would create emissions of dust (particulate matter), fumes, equipment exhaust, and other air contaminant effects.

Construction activities would exceed BAAQMD's NO<sub>x</sub> threshold. Mitigation measures would control fugitive dust (AQ-CNST-A) and reduce NO<sub>x</sub> emissions (AQ-CNST-B through AQ-CNST-I). Implementation of Tier 3 engine exhaust controls would reduce equipment-related NO<sub>x</sub>. However, the NO<sub>x</sub> emissions would still be greater than the BAAQMD threshold even after mitigation. Therefore, construction would result in adverse, short-term air quality effects with regard to NO<sub>x</sub> emissions.

For comparative purposes, because the area to be disturbed by cut-and-cover excavation for the Single-Bore Option would be much smaller than for the Twin-Bore Option, air pollutant emissions would be less for the Single-Bore Option than with the Twin-Bore Option with regard to impacts on the surrounding community.

Because the area within 0.5 miles of the alignment is mostly minority and low-income and construction of stations and aboveground facilities would be in areas that are predominantly minority and low-income, adverse air quality construction effects would be mostly borne by environmental justice populations. However, areas around the Downtown San Jose and Diridon Stations are frequented by non-environmental justice populations, including office goers and transit users who would also be exposed to the same level of emissions from

construction activities. Therefore, effects from construction would occur within or immediately adjacent to populations that are considered to be environmental justice populations as well as non-environmental justice populations. The same mitigation measures would be implemented throughout the construction area irrespective of location.

In an overall assessment of construction air quality, taking into account the benefits of extending BART service to minority and low-income areas and providing additional transit opportunities to this area, this effect is *not disproportionately high and adverse* on environmental justice populations for both the Twin-Bore and Single-Bore Options.

## **Socioeconomics**

As described in Section 5.5.15, *Socioeconomics*, construction of the BART Extension has the potential to adversely affect traffic and transit, which would impede access to public facilities, businesses, and residences within the study area. Residents, businesses, and visitors along the alignment would also be subject to noise, dust, vibration, and emissions from construction equipment during construction. These impacts could discourage or restrict pedestrian activity along the blocks under construction and reduce foot traffic, which could impact local business revenues. In addition, on-street parking availability within the study area would be limited during construction. Due to the impacts listed above, and due to the long construction duration, there would be an *adverse effect* on socioeconomics during construction.

For comparative purposes, because the area to be disturbed by cut-and-cover excavation for the Single-Bore Option would be much smaller than for the Twin-Bore Option, the socioeconomic effects would be less for the Single-Bore Option than with the Twin-Bore Option with regard to impacts on the surrounding community.

As described, the study area is composed of predominantly environmental justice populations, although there are non-environmental justice populations distributed within a 0.5-mile distance of the alignment. Both environmental justice populations and non-environmental justice populations visit and are employed by business establishments and offices within the study area.

VTA will ensure traffic, bicycle, and pedestrian traffic would be maintained where feasible. The severity of these effects would be reduced by adherence to regulations and mitigation measures listed below. VTA will work with property and business owners to minimize disruption and maintain access throughout construction. VTA will implement Mitigation Measure TRA-CNST-A as described in Section 5.5.1, *Construction Education and Outreach Plan*. Construction of the BART Extension Alternative would also provide work opportunities for the community. This is a potentially beneficial effect for the local economy. Therefore, although the BART Extension would cause adverse socioeconomic effects during construction, these adverse effects would be *not disproportionately high and adverse* to environmental justice populations for both the Twin-Bore and Single-Bore Options.

## Hazards and Hazardous Materials

As described in Section 5.5.11, *Hazards and Hazardous Materials*, known and/or anticipated subsurface contamination are located within the study area of the BART Extension.

Disturbance of contaminated materials during construction activities, such as excavation and dewatering, could pose a potential threat to human health and the environment.

For comparative purposes, because the area to be disturbed by cut-and-cover excavation for the Single-Bore Option would be much smaller than for the Twin-Bore Option, the hazardous materials effects would be less for the Single-Bore Option than with the Twin-Bore Option.

As described, the study area is composed of predominantly environmental justice populations, although there are non-environmental justice populations distributed within a 0.5-mile distance of the alignment. The study area contains known hazardous materials release sites. These sites are located throughout the study area within areas that are considered to be environmental justice populations and within areas that are not considered to be environmental justice populations. Implementation of the CMP and Mitigation Measure HAZ-CNST-A would ensure that site-specific remedial action plans are prepared and implemented so that no adverse effect on human health and the environment would occur. As a result, the hazardous materials effects on environmental justice populations would not be appreciably more severe or greater in magnitude than the adverse effect on non-environmental justice populations. Therefore, hazardous materials effects from construction would be *not disproportionately high and adverse* on environmental justice populations for both the Twin-Bore and Single-Bore Options.

## Noise and Vibration

Construction of the BART Extension Alternative has the potential to generate high levels of noise and vibration. Construction of the stations and ventilation structures would potentially result in adverse effects on nearby sensitive receptors when construction noise would exceed city standards. Additionally, use of the TBM would result in potentially adverse effects on sensitive receptors (particularly those within 50 feet of the TBM) for a temporary period (about 4 days).

To the extent feasible, construction would adhere to the noise ordinances of the local jurisdiction. The local jurisdiction's construction work hours are as follows.

- In the City of San Jose, construction work will be limited where feasible to the hours of 7 a.m. to 7 p.m. every day of the week, except holidays.
- In the City of Santa Clara, construction work will comply, where feasible, with Section 9.10.040 of the City of Santa Clara City Code, which includes regulations related to noise generated by construction and stipulates that no construction activity will commence prior to 7 a.m. or continue later than 6 p.m. Monday through Friday, or prior to 9 a.m. and after 6 p.m. on Saturdays that are not holidays.

Certain construction activities, such as emergency work (water main break), utilities work, or work activities performed at night to avoid other impacts (such as traffic) require extended work hours and may be exempted from these constraints after coordinating with the Cities.

For comparative purposes, because the area to be disturbed by cut-and-cover excavation for the Single-Bore Option would be much smaller than for the Twin-Bore Option, the noise and vibration effects would be less for the Single-Bore Option than with the Twin-Bore Option.

The study area is composed of predominantly environmental justice populations, although there are non-environmental justice populations distributed within 0.5 mile of the alignment. Noise and vibration effects would occur throughout the study area within areas that are considered to be environmental justice populations and within areas that are not considered to be environmental justice populations. Implementation of noise and vibration mitigation measures (Mitigation Measures NV-CNST-A through NV-CNST-O) would reduce effects so that no adverse effects would occur except for construction noise impacts at the Downtown San Jose and Diridon Stations. Because of the magnitude and duration (see Table 5-2 for Twin-Bore Option construction durations, which has greater impacts than the Single-Bore Option) of the construction activities at the Downtown San Jose and Diridon Stations, including cut-and-cover construction for both the Twin-Bore and Single-Bore Options, noise impacts would be considered adverse. However, the effects would not be appreciably more severe or greater in magnitude than the adverse effect on non-environmental justice populations. Therefore, noise and vibration effects from construction would be *not disproportionately high and adverse* on environmental justice populations for both the Twin-Bore and Single-Bore Options.

## Transportation

Construction of the BART Extension Alternative would result in disruptions to vehicle, transit, bicycle, and pedestrian accessibility within the study area during construction. Roadway and sidewalk closures would be disruptive from bus re-routing, bus stop relocation, loss of parking, and limited vehicular accessibility. Compared to the Twin-Bore Option, the Single-Bore Option would involve less cut-and-cover excavation at the three underground stations and would, therefore, result in less disruptions at the street level than the Twin-Bore Option.

The study area is composed of predominantly environmental justice populations, although there are non-environmental justice populations distributed within 0.5 mile of the alignment. Implementation of mitigation measures (Mitigation Measures TRA-CNST-A through TRA-CNST-D) would reduce impacts on vehicle, transit, bicycle, and pedestrian traffic. However, construction would still have an adverse effect on vehicular traffic and bicycle/pedestrian traffic for both the Twin-Bore and Single-Bore Options for the Alum Rock/28<sup>th</sup> Street, Downtown San Jose, and Diridon Stations. Construction of the Newhall Maintenance Facility, West Portal, and Santa Clara Station would have an adverse effect on vehicular traffic for both the Twin-Bore and Single-Bore Options.

Such effects would be experienced throughout the study area within areas that are considered to be environmental justice populations and within areas that are not considered to be environmental justice populations. Additionally, such effects would be experienced by environmental justice populations and non-environmental justice populations that visit or are employed by business establishments and offices within the study area. While the effect is *adverse*, it would not be primarily borne by environmental justice populations. Therefore, the transportation effects from construction would be *not disproportionately high and adverse* on environmental justice populations for both the Twin-Bore and Single-Bore Options.

## **Water Resources, Water Quality, and Floodplains**

Construction of the BART Extension Alternative would potentially result in short-term surface and groundwater quality effects. Surface water impacts could result from sediment transport to drainage facilities and stormwater flooding. Groundwater impacts could result from excavations into the groundwater table necessitating dewatering.

For comparative purposes, because the area to be disturbed by cut-and-cover excavation for the Single-Bore Option would be much smaller than for the Twin-Bore Option, the water resources, water quality, and floodplains effects would be less for the Single-Bore Option than with the Twin-Bore Option.

The study area is composed of predominantly environmental justice populations, although there are non-environmental justice populations distributed within 0.5 mile of the alignment. Potential water quality effects would occur throughout the study area within areas that are considered to be environmental justice populations and within areas that are not considered to be environmental justice populations. Implementation of Mitigation Measures BIO-CNST-D and HAZ-CNST-A would reduce effects so no that adverse effects would occur and effects would not be appreciably more severe or greater in magnitude than the adverse effect on non-environmental justice populations. Therefore, water quality effects from construction would be *not disproportionately high and adverse* on environmental justice populations for both the Twin-Bore and Single-Bore Options.

## **Visual Quality**

Construction of the BART Extension Alternative would result in visual changes as a result of construction. Construction visual impacts would result from equipment operations and storage, stockpiling, and removal of trees among other impacts.

For comparative purposes, because the area to be disturbed by cut-and-cover excavation for the Single-Bore Option would be much smaller than for the Twin-Bore Option, the visual quality effects would be less for the Single-Bore Option than with the Twin-Bore Option.

The study area is composed of predominantly environmental justice populations, although there are non-environmental justice populations distributed within 0.5 mile of the alignment. Potential visual effects would occur throughout the study area within areas that are considered to be environmental justice communities and within areas that are not considered

to be environmental justice populations. Implementation of Mitigation Measure AES-CNST-A would reduce effects so that no adverse effects would occur, and effects would not be appreciably more severe or greater in magnitude than the adverse effect on non-environmental justice populations. Therefore, visual effects from construction would be *not disproportionately high and adverse* on environmental justice populations for both the Twin-Bore and Single-Bore Options.

### 5.5.19.3 Summary

Construction of the BART Extension would have direct and indirect effects on populations within the vicinity of the alignment. The BART Extension Alternative would have construction-period environmental effects related to air quality, socioeconomics, hazards and hazardous materials, noise and vibration, water quality, and visual quality. Environmental effects would be mitigated, where feasible, ensuring that effects on low-income and minority communities would be reduced. However, both environmental justice populations and non-environmental justice populations would experience adverse construction-related effects for air quality, noise, and transportation because such effects would continue to be adverse with mitigation.

While construction would last for up to 8 years, the magnitude of construction activities would vary substantially as the activity moves from one location to another. Although construction would be phased so that adverse construction-related effects would not be experienced at the same time, and although VTA will implement a comprehensive Construction Education and Outreach Plan, the community and businesses would experience intermittent adverse construction-related air quality, noise, and transportation effects depending on the phase of construction.

However, implementation of the BART Extension Alternative would have a long-term beneficial effect on the community by increasing public transit service and capacity, enhancing regional connectivity, improving mobility options, and improving regional air quality by reducing auto emissions. Both environmental justice populations and non-environmental just populations would experience these long-term benefits.

A finding on Environmental Justice requires that mitigation and benefits be considered along with the adverse impacts. In conclusion, adverse effects caused by construction would affect both environmental justice populations and non-environmental justice populations, implementation of mitigation measures would reduce construction-period impacts for all populations, and there will be economic benefits created during construction for firms meeting disadvantage business criteria. As a result, construction of the project would not result in a *disproportionately high and adverse* impact on environmental justice populations in the study area.



*This page intentionally left blank.*